



behringer X-TOUCH COMPACT Universal USB/MIDI Controller User Guide

[Home](#) » [Behringer](#) » behringer X-TOUCH COMPACT Universal USB/MIDI Controller User Guide



behringer

X-TOUCH COMPACT Universal USB/MIDI Controller

Quick Start Guide

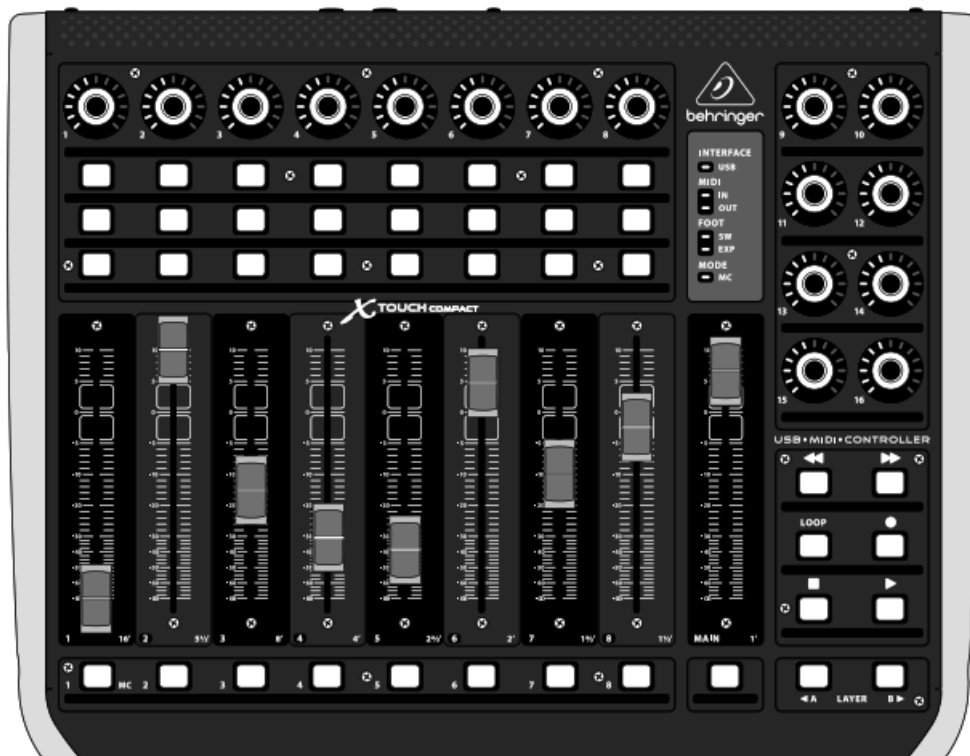

X-TOUCH COMPACT

Universal USB/MIDI Controller with 9 Touch-Sensitive Motor Faders

Contents [[hide](#)]

- [1 Important Safety Instructions](#)
- [2 LEGAL DISCLAIMER](#)
- [3 LIMITED WARRANTY](#)
- [4 X-TOUCH COMPACT Hook-up](#)
- [5 X-TOUCH COMPACT Controls](#)
- [6 Step 2: Controls](#)
- [7 X-TOUCH COMPACT Getting started](#)
- [8 X-TOUCH COMPACT BLOCK DIAGRAM](#)
- [9 X-TOUCH COMPACT MIDI MAP](#)
- [10 X-TOUCH COMPACT MIDI MAP](#)
- [11 X-TOUCH COMPACT RX MIDI DATA](#)
- [12 Specifications](#)
- [13 Important information](#)
- [14 FEDERAL COMMUNICATIONS COMMISSION COMPLIANCE INFORMATION](#)
- [15 Documents / Resources](#)
 - [15.1 References](#)
- [16 Related Posts](#)

Important Safety Instructions



Terminals marked with this symbol carry an electrical current of sufficient magnitude to constitute a risk of electric shock. Use only high-quality professional speaker cables with ¼" TS or twist-locking plugs pre-installed. All other installation or modifications should be performed only by qualified personnel.



This symbol, wherever it appears, alerts you to the presence of uninsulated dangerous voltage inside the enclosure – voltage that may be sufficient to constitute a risk of shock. This symbol, wherever it appears, alerts you to important operating and maintenance instructions in the accompanying literature. Please read the manual.



Caution

To reduce the risk of electric shock, do not remove the top cover (or the rear section). No user-serviceable parts inside. Refer servicing to qualified personnel.



Caution

To reduce the risk of fire or electric shock, do not expose this appliance to rain and moisture. The apparatus shall not be exposed to dripping or splashing liquids and no objects filled with liquids, such as vases, shall be placed on the apparatus.



Caution

These service instructions are for use by qualified service personnel only. To reduce the risk of electric shock do not perform any servicing other than that contained in the operation instructions. Repairs have to be performed by qualified service personnel.

1. Read these instructions.
2. Keep these instructions.
3. Heed all warnings.
4. Follow all instructions.
5. Do not use this apparatus near water.
6. Clean only with a dry cloth.
7. Do not block any ventilation openings. Install in accordance with the manufacturer's instructions.
8. Do not install near any heat sources such as radiators, heat registers, stoves, or other apparatus (including amplifiers) that produce heat.
9. Do not defeat the safety purpose of the polarized or grounding-type plug. A polarized plug has two blades with one wider than the other. A grounding-type plug has two blades and a third grounding prong. The wide blade or the third prong are provided for your safety. If the provided plug does not fit into your outlet, consult an electrician for the replacement of the obsolete outlet.
10. Protect the power cord from being walked on or pinched particularly at plugs, convenience receptacles, and the point where they exit from the apparatus.
11. Use only attachments/accessories specified by the manufacturer.
12. Use only with the cart, stand, tripod, bracket, or table specified by the manufacturer, or sold with the apparatus. When a cart is used, use caution when moving the cart/apparatus combination to avoid injury from tip-over.
13. Unplug this apparatus during lightning storms or when unused for long periods of time.
14. Refer all servicing to qualified service personnel. Servicing is required when the apparatus has been damaged in any way, such as power supply cord or plug is damaged, liquid has been spilled or objects have fallen into the apparatus, the apparatus has been exposed to rain or moisture, does not operate normally, or has been dropped.
15. The apparatus shall be connected to a MAINS socket outlet with a protective earthing connection.
16. Where the MAINS plug or an appliance coupler is used as the disconnect device, the disconnect device shall remain readily operable.
17. Correct disposal of this product: This symbol indicates that this product must not be disposed of with household waste, according to the WEEE Directive (2012/19/EU) and your national law. This product should be taken to a collection center licensed for the recycling of waste electrical and electronic equipment (EEE). The mishandling of this type of waste could have a possible negative impact on the environment and human health due to potentially hazardous substances that are generally associated with EEE. At the same time, your cooperation in the correct disposal of this product will contribute to the efficient use of natural resources. For more information about where you can take your waste equipment for recycling, please contact your local city office or your household waste collection service.
18. Do not install in a confined space, such as a bookcase or similar unit.
19. Do not place naked flame sources, such as lighted candles, on the apparatus.
20. Please keep the environmental aspects of battery disposal in mind. Batteries must be disposed of at a battery collection point.
21. This apparatus may be used in tropical and moderate climates up to 45°C.



LEGAL DISCLAIMER

Music Tribe accepts no liability for any loss which may be suffered by any person who relies either wholly on or in

part upon any description, photograph, or statement contained herein. Technical specifications, appearances, and other information are subject to change without notice. All trademarks are the property of their respective owners. Midas, Klark Teknik, Lab Gruppen, Lake, Tannoy, Turbosound, TC Electronic, TC Helicon, Behringer, Bugera, Oberheim, Auratone, and Coolaudio are trademarks or registered trademarks of Music Tribe Global Brands Ltd. © Music Tribe Global Brands Ltd. 2021 All rights reserved.

LIMITED WARRANTY

For the applicable warranty terms and conditions and additional information regarding Music Tribe's Limited Warranty, please see complete details online at musictribe.com/warranty.

X-TOUCH COMPACT Hook-up

Step 1: Hook-Up

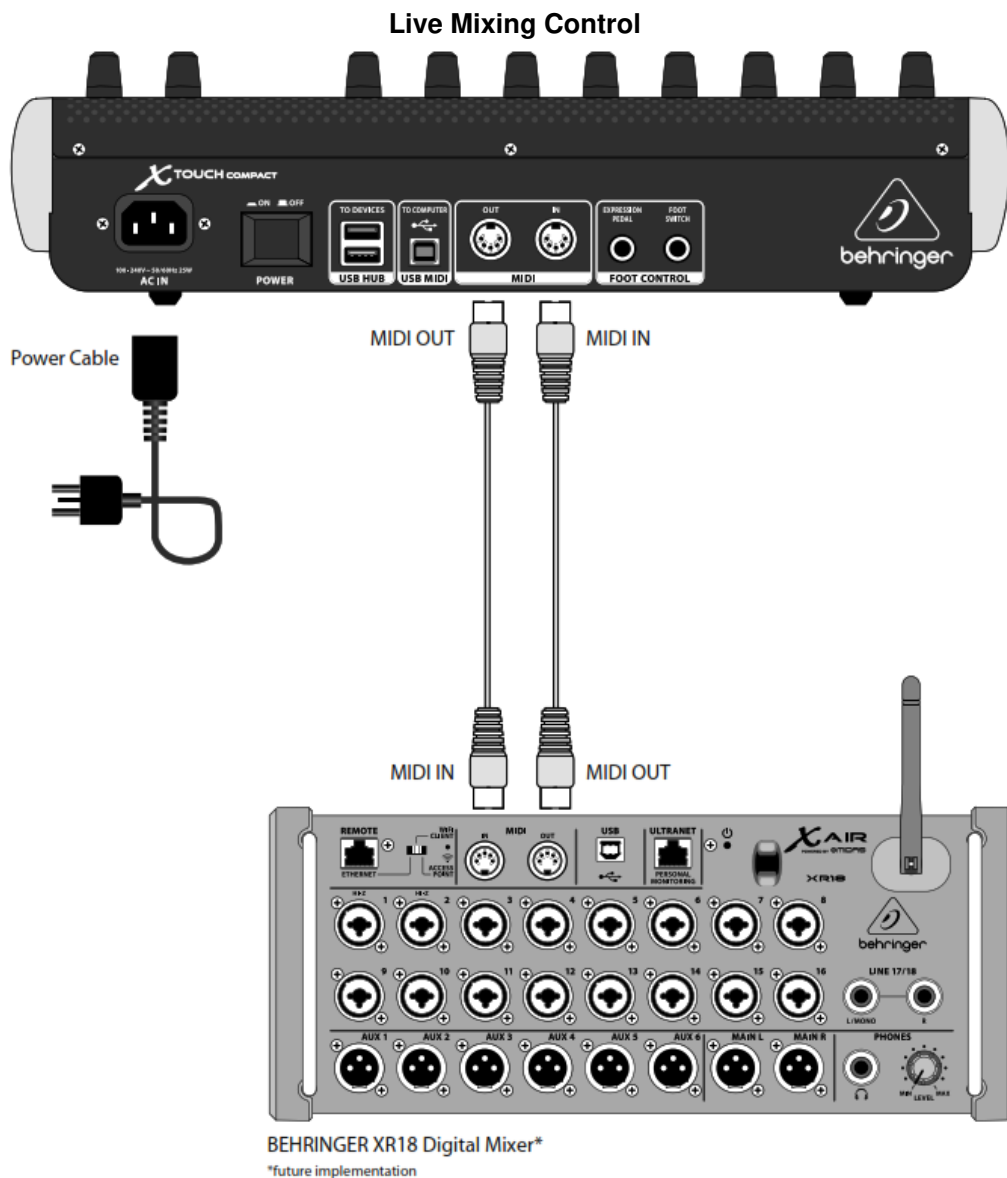

DJ Performance

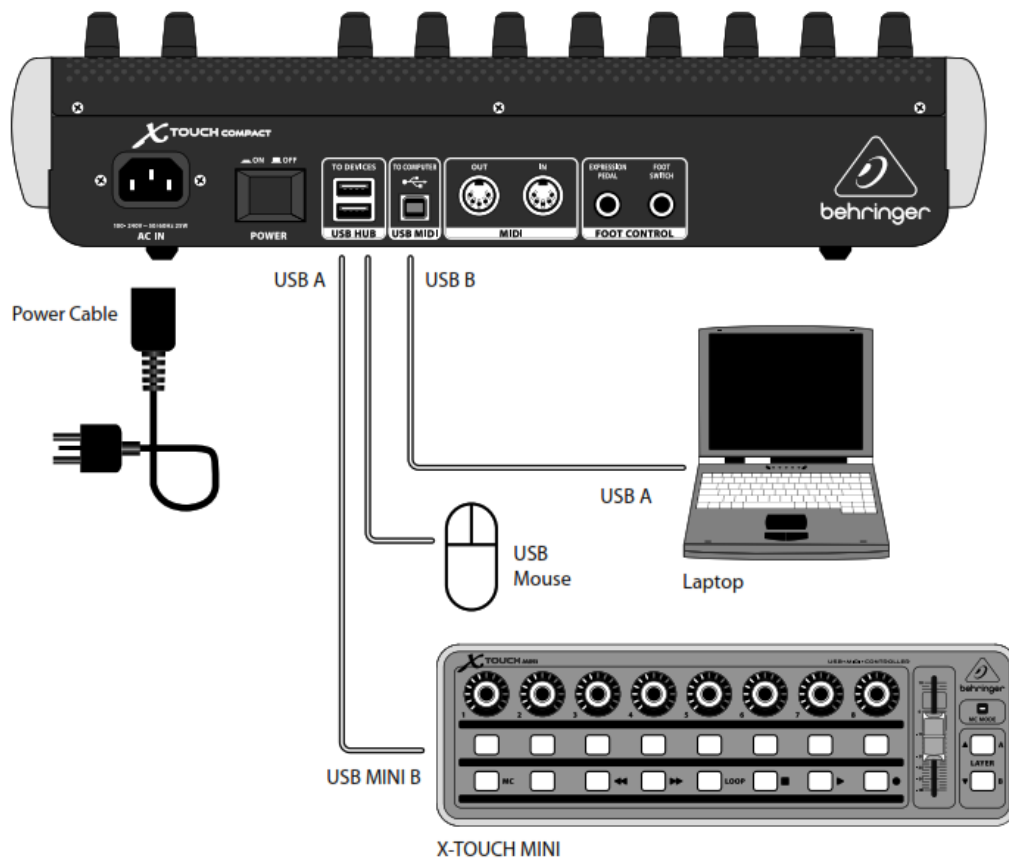

Home Studio

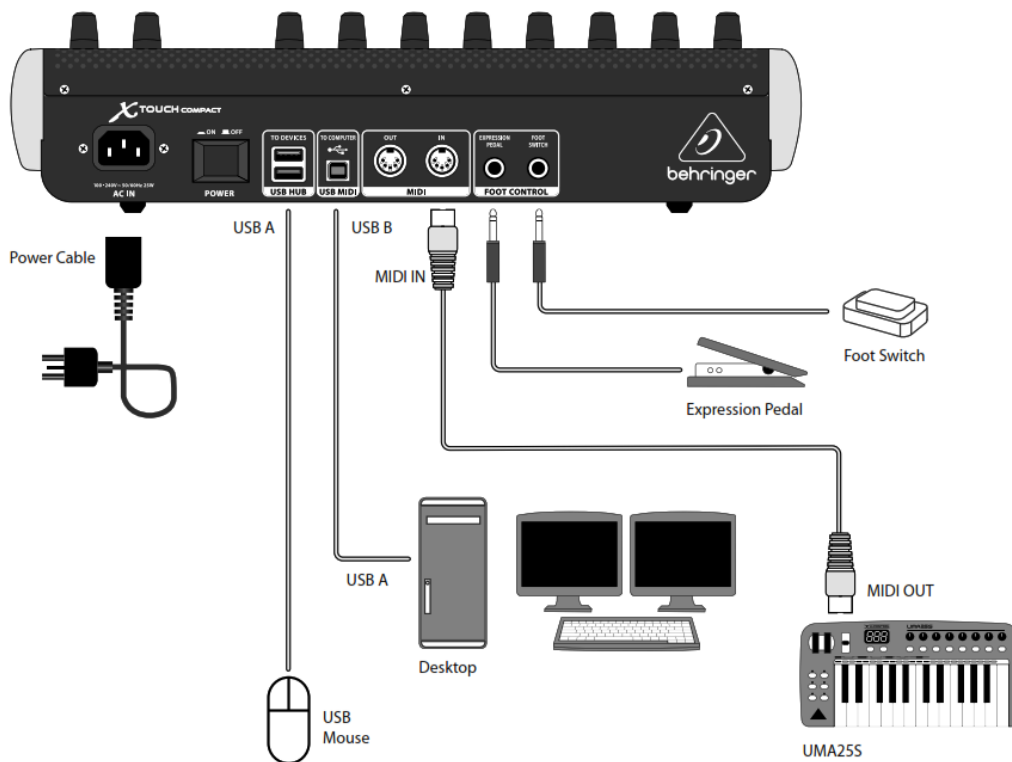

X-TOUCH COMPACT Controls

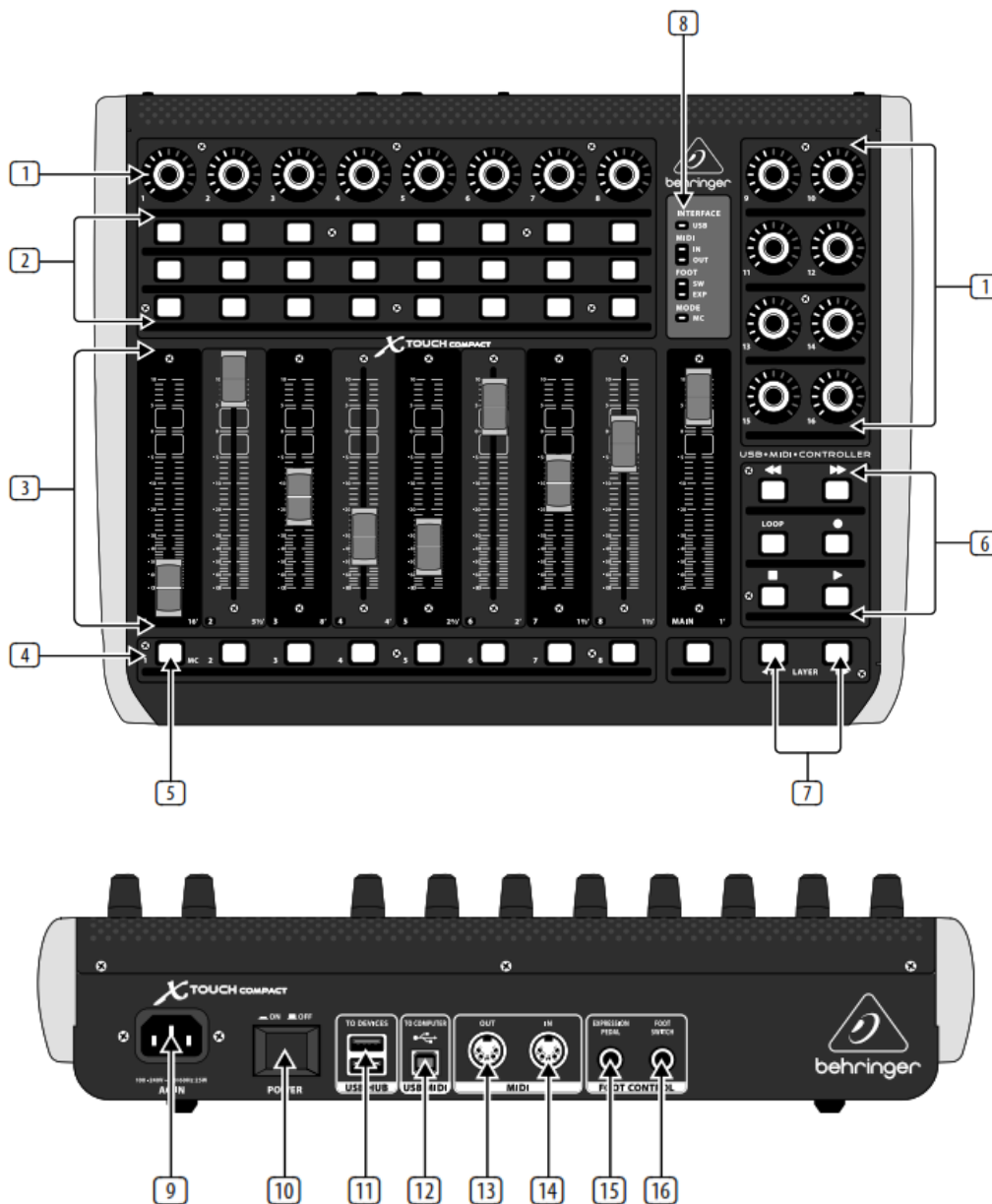

Step 2: Controls

1. **Push encoder knobs** – these 16 endless encoders each have a detent and push function (not illuminated), and a 13-segment amber LED ring. The top row of 8 knobs are typically used in Digital Audio Workstation (DAW) applications for fine control of parameters such as level or pan control of channels 1 to 8, and the 8 knobs on the right can be used for individual-level and EQ adjustments.
2. **Select buttons** – these 3 x 8 buttons are typically used for DAW mixer channel applications such as solo or mute of channels 1 to 8.
3. **Faders** – these touch-sensitive motorized 100 mm faders are typically used for fine control of level functions in DAW applications. There are 8 channel faders and 1 master on the right. The faders can also be used for drawbar control of virtual organs. For this use, the value range can be inverted in the X-TOUCH editor software (min = 127, max = 0). Typical drawbar organ printing (16', 5 1/3', 8' etc.) can be found next to the fader numbers (1, 2, 3..).
4. **Select buttons** – these 9 buttons are typically used for lighting applications (spotlight on/off), and sample triggering (notes on/off).
5. **MC button** – this select button can also be used to switch the unit between Mackie Control mode and standard mode. See the “Getting Started” section for more details.

6. **Select buttons** – these 6 buttons are typically used for DAW transport applications (e.g. play, rec, stop). They can also be reconfigured using the X-TOUCH editor software.
7. **Layer A and B buttons** – these 2 buttons allow selection between preset layer A (mixer control) and B (instrument control), in standard mode. In MC mode, there are different assignments. See MIDI Maps on pages 19 to 21. Presets can be saved or loaded to and from the computer using the X-TOUCH editor software.
8. **LED section** – these LEDs show the status of the X-TOUCH COMPACT:
 - INTERFACE USB** – lit when the unit is connected correctly to the USB port of a live computer
 - MIDI IN** – lit when MIDI data is received
 - MIDI OUT** – lit when MIDI data is sent out
 - FOOT SW** – lit when the footswitch is in operation
 - FOOT EXP** – lit when the expression pedal is in operation
 - MODE MC** – lit when the unit is in Mackie Control mode
9. **AC IN** – securely connect the supplied AC power cord here.
10. **POWER** – press in to turn on the unit, press out to turn it off.
11. **USB HUB** – these 2 USB type A connectors are used for connecting external USB hardware such as a USB mouse, a keyboard, USB MIDI controllers such as the X-TOUCH MINI, and USB MIDI keyboards. The Hub communicates directly to the computer and not to the X-TOUCH COMPACT. Each connector can supply 5V USB power. The hub is only active when the X-TOUCH COMPACT is powered on, and in USB mode, connected to a live computer via the USB MIDI connector.
12. **USB MIDI** – this USB type B connector is used to connect to a computer's USB port for MIDI data transfer (send/receive), and USB Hub communications. The X-TOUCH COMPACT will operate in USB mode when connected to a live computer via the supplied USB cord. It can also operate in stand-alone mode with no USB connection.
13. **MIDI OUT** – this 5-pin DIN connector sends MIDI data to external MIDI devices. In USB mode, the X-TOUCH COMPACT only sends MIDI data received directly from the host computer. In stand-alone mode, it sends MIDI data from the X-TOUCH COMPACT, merged with any MIDI IN signals.
14. **MIDI IN** – this 5-pin DIN connector receives MIDI data from external MIDI devices. In USB mode, the X-TOUCH COMPACT routes any incoming MIDI data only to the host computer. In stand-alone mode, it routes it to the MIDI OUT connector (thru data) and also sends it to the X-TOUCH COMPACT (parameter feedback).
15. **Foot Control Expression Pedal** – this 1/4" connector is used for a standard swell pedal for continuous MIDI data control. The editor software allows control over the MIDI data assignment and control behavior.
16. **Foot Control Foot Switch** – this 1/4" connector is used for a standard sustain pedal for momentary or toggle MIDI data control. The editor software allows control over the MIDI data assignment, switch behavior and polarity.

X-TOUCH COMPACT Getting started

Step 3: Getting started

OVERVIEW

This 'Getting Started Guide' will help you set up your X-TOUCH COMPACT and briefly introduce its capabilities. The X-TOUCH COMPACT is a very useful helper to expand software DAW/instrument control with 39 handy illuminated buttons, 16 rotary push-encoders, and 9 touch-sensitive motorized 100 mm faders. It can also be used as a stand-alone trigger controller for mobile / live performance. It has predefined standard MIDI assignments in 2 selectable preset layers: A (mixer control) and B (instrument control), and an MC (Mackie Control) mode. Editing (if required) can be done using the free X-TOUCH editor software. Alternatively, your DAW or soft instrument can

“learn” the assigned X-TOUCH COMPACT functions.

SOFTWARE SET-UP

The X-TOUCH COMPACT is a USB Class Compliant MIDI device, and so no driver installation is required. The X-TOUCH editor software application and its quick start guide are available as free downloads from behringer.com. This application is the only way that the MIDI functions of the unit can be edited, and the firmware updated.

HARDWARE SET-UP

Connect your X-TOUCH COMPACT directly to an available USB port on your Mac* or PC using the supplied USB cable. It is also possible to connect to an iPad* or another iOS device via either the Apple* Lightning* to USB Camera Adapter, or the iPad Camera Connection Kit USB adapter for older 30-pin devices. Apply AC power to the X-TOUCH COMPACT and turn on its power switch.

MACKIE CONTROL MODE

To switch between standard operating mode and MC (Mackie Control) mode, press and hold down the MC button in the bottom left corner, and then turn on the unit’s power switch. Keep holding down the MC button until the MC MODE LED lights continuously to show that the unit is in MC mode. The unit will stay in the current mode even when the unit is turned on or off. Repeat this procedure to change back to standard mode, only this time, make sure the MC MODE LED turns off instead.

X-TOUCH COMPACT BLOCK DIAGRAM

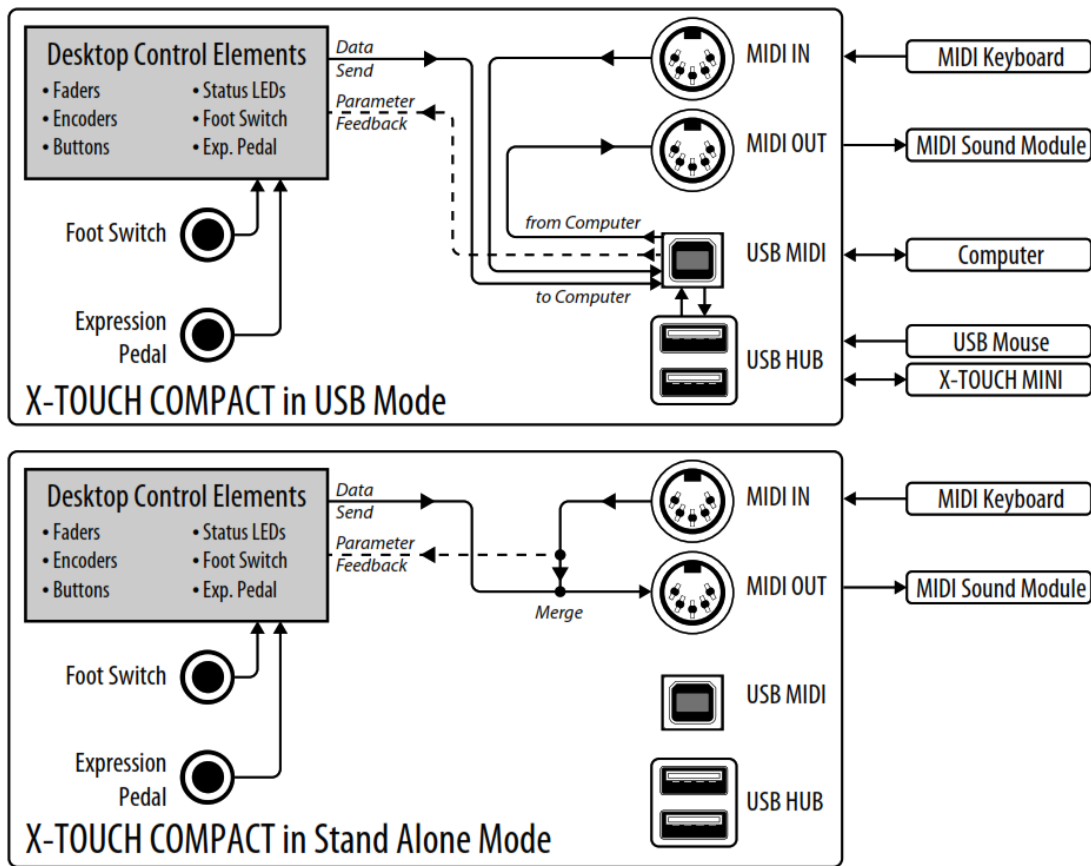

Notes:

The X-TOUCH COMPACT will detect if a computer is connected to the USB MIDI socket: If it is, then USB Mode is active.

If not, then it will automatically switch to Stand Alone Mode.

X-TOUCH COMPACT MIDI MAP

PRESET LAYER A “Mixer Control” (MIDI Channel =1)

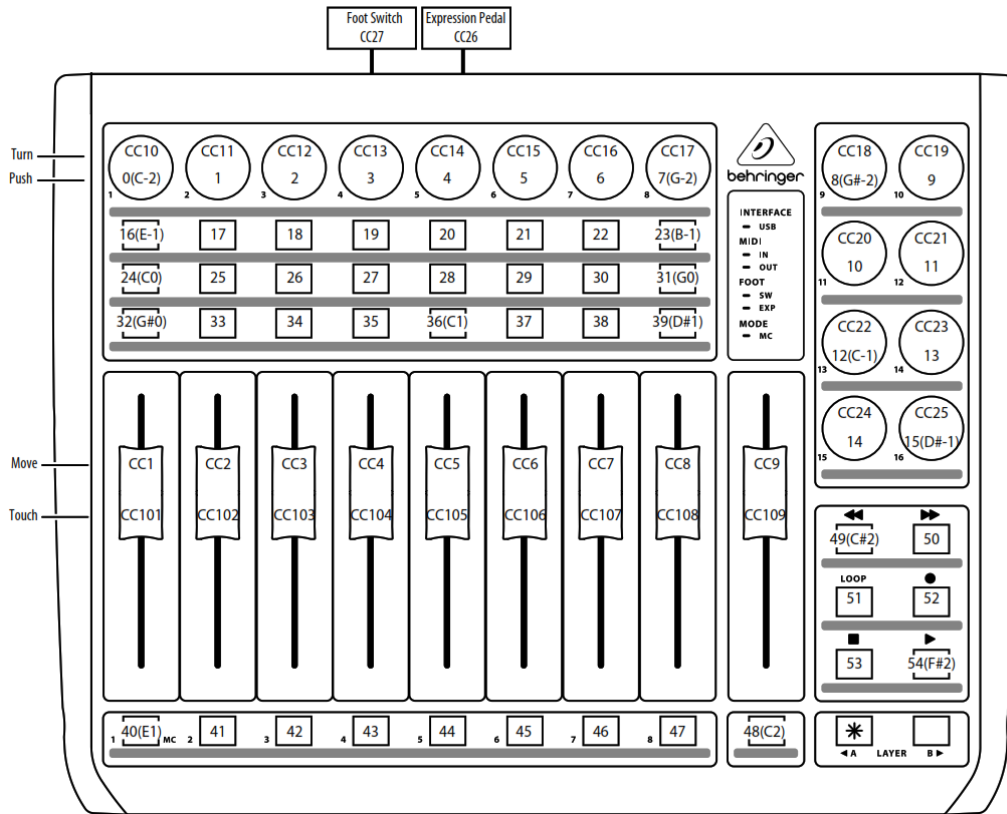

Notes:

Every push function (encoders + buttons) is a NOTE command.

The encoder rotation, fader movement, fader touch, and foot control functions have CC commands.

X-TOUCH COMPACT MIDI MAP

PRESET LAYER B "Instrument Control" (MIDI Channel =1)

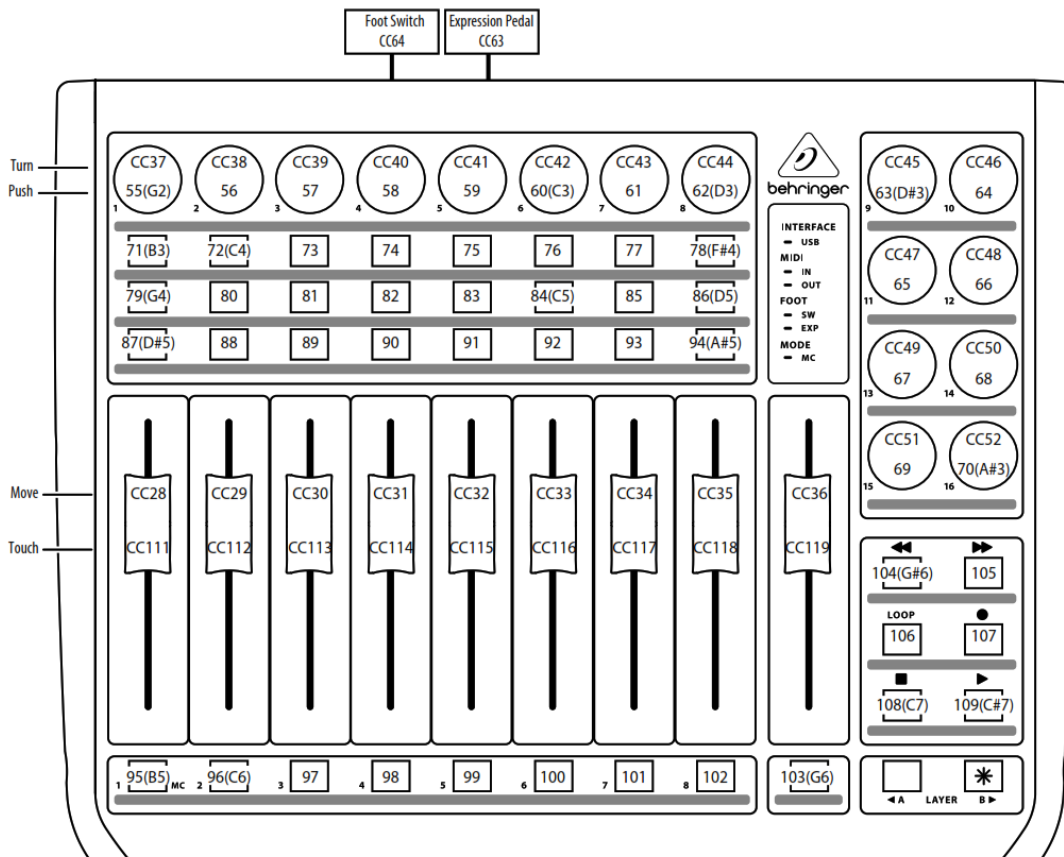

Notes:

Every push function (encoders + buttons) is a NOTE command.

The encoder rotation, fader movement, fader touch, and foot control functions have CC commands.

Mackie Control Mode MC Assignment

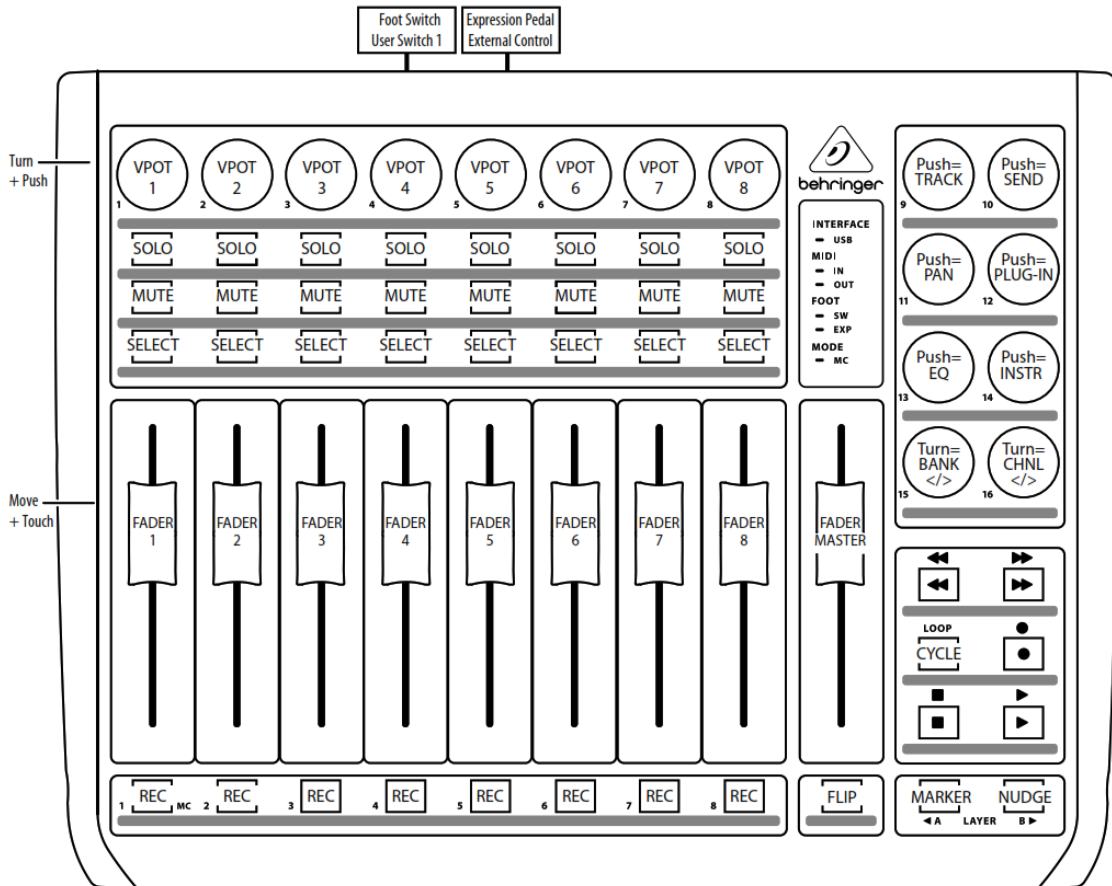

Notes:

Encoders 9 to 14: Push = VPOT ASSIGN; Turn is not assigned.

Encoders 15, 16: Turn = Fader Bank and Channel select; Push is not assigned.

X-TOUCH COMPACT RX MIDI DATA

This RX MIDI data table shows what can get controlled and changed from outside (via MIDI receive) independent of the X-TOUCH editor software.

Operation Mode Select	GLOBAL CH	CC 127	0= Standard Mode, MC Mode LED off 1= MC Mode, MC Mode LED on 2-127 = ignored
Preset Layer Change	GLOBAL GI	Program Change	ONLY in Standard Mode (see above): 0 = Layer A, A-button LED on 1= Layer B, B-button LED on 2-127 = ignored
Fader Movement	GLOBAL CH	CC 1 —CC 9	0-127 = Fader position, bottom to top

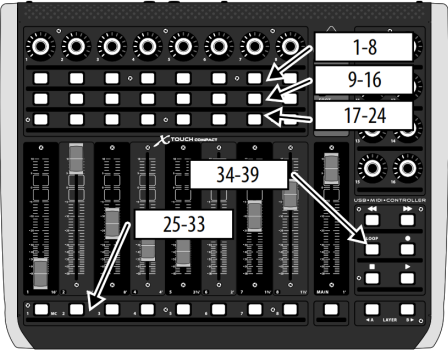
LED Ring Behavior Change	GLOBAL CH	Encoders 1-8: CC 10— CC 17 Encoders 9-16: CC 18 —CC 25	0 = Single 1 =Pan 2 =Fan 3 = Spread 4 = Trim 5-127 = ignored
LED Ring Remote Control (Value Change)	GLOBAL GI	Encoders 1-8: CC 26 — CC 33 Encoders 9-16: CC 34 — CC 41	0 = all LEDs off 1-13 = LEDs 1 (left) —13 (right) on 14-26 = LEDs 1 (left) —13 (right) blinking 27 = all LEDs on 28 = all LEDs blinking 29-127 = ignored
Buttons LED Remote Control	GLOBAL GI	Upper Top Row 1-8: Note 0 — Note 7 Upper Mid Row 9-16: Note 8— Note 15 Upper Bottom Row 17-24: Note 16 — Note 23 Lower Row 25-33: Note 24 — Note 32 Right Area 34-39: Note 33 — Note 38 Layer A, B LEDs: Not assignable; only 1 of 2 LEDs lights if Standard mode selected (see above 'Preset Layer Change")	<p>Note off or Note on with Velocity0: Button LED off Note on with Velocity 1: Button LED on Note on with Velocity 2: Button LED blinking Note on with Velocity 3-127: ignored</p> 
Status LEDs Remote Control	GLOBAL CH	Foot Switch LED: CC 42 Exp. Pedal LED: CC 43 MC Mode LED: Not assignable; lights only if MC mode selected (see above "Operation Mode Select") USB LED: Not assignable; always active if valid connection to computer available MIDI I/O LEDs: Not assignable; always active while data transfer	For Foot Switch: 0-63 = LED off 64-127 = LED on For Expression Pedal: LED only on while data transfer (value change)

Specifications

Controls	
Rotary/Push controls with LED collar	16
Buttons with LED backlight	39
Faders	9 motorized faders, 100 mm, touch-sensitive
Foot control (expression)	1/4" TS
Footswitch (sustain)	1/4" TS
Presets (*user-programmable)	A*, B*, MC mode
MIDI	
Input	5-pin DIN
Output	5-pin DIN
Communication in USB mode	MIDI interface for computer only
Communication in stand alone mode	MIDI in with merge to MIDI out
Computer Connection	
USB	USB 2.0, type B
USB Hub	
Type	Multi-TT USB 2.0
Connectors (x2)	USB 2.0, type A
Voltage (USB power to external devices)	5 V
Communication	Between external devices and computer, not to unit
Active	Hub active only when unit in USB mode
Power Supply	
Type	Internal switch mode power supply
Voltage	100-240 VAC, 50/60 Hz
Fuse	T 1A H 250V
Power consumption	25 W
Mains connection	Standard IEC receptacle
Physical	
Standard operating temperature range	5°C to 40°C (41°F to 104°F)
Dimensions (H x W x D)	100 x 391 x 301 mm (3.9 x 15.4 x 11.9")
Weight	3.7 kg (8.2 lbs)

Important information

1. **Register online.** Please register your new Music Tribe equipment right after you purchase it by visiting

musictribe.com. Registering your purchase using our simple online form helps us to process your repair claims more quickly and efficiently. Also, read the terms and conditions of our warranty, if applicable.

2. **Malfunction.** Should your Music Tribe Authorized Reseller not be located in your vicinity, you may contact the Music Tribe Authorized Fulfiller for your country listed under “Support” at musictribe.com. Should your country not be listed, please check if your problem can be dealt with by our “Online Support” which may also be found under “Support” at musictribe.com. Alternatively, please submit an online warranty claim at musictribe.com BEFORE returning the product.
3. **Power Connections.** Before plugging the unit into a power socket, please make sure you are using the correct mains voltage for your particular model. Faulty fuses must be replaced with fuses of the same type and rating without exception.

FEDERAL COMMUNICATIONS COMMISSION COMPLIANCE INFORMATION

Behringer X-TOUCH COMPACT

Responsible Party Name: **Music Tribe Commercial NV Inc.**
Address: **5270 Procyon Street, Las Vegas NV 89118, United States**
Phone Number: **+1 702 800 8290**

X-TOUCH COMPACT

This equipment has been tested and found to comply with the limits for a Class A digital device, pursuant to part 15 of the FCC Rules. These limits are designed to provide reasonable protection against harmful interference when the equipment is operated in a commercial environment. This equipment generates, uses, and can radiate radio frequency energy and, if not installed and used in accordance with the instruction manual, may cause harmful interference to radio communications. Operation of this equipment in a residential area is likely to cause harmful interference in which case the user will be required to correct the interference at his own expense.

This equipment complies with Part 15 of the FCC Rules. Operation is subject to the following two conditions:

1. This device may not cause harmful interference, and
2. This device must accept any interference received, including interference that may cause undesired operation.

Warning: Operation of this equipment in a residential environment could cause radio interference.

Important information:

Changes or modifications to the equipment not expressly approved by Music Tribe can void the user's authority to use the equipment.



Hereby, Music Tribe declares that this product is in compliance with Directive 2014/35/EU, Directive 2014/30/EU, Directive 2011/65/EU and Amendment 2015/863/ EU, Directive 2012/19/EU, Regulation 519/2012 REACH SVHC and Directive 1907/2006/EC.

Full text of EU DoC is available at <https://community.musictribe.com/>



EU Representative: Music Tribe Brands DK A/S

Address: Ib Spang Olsens Gade 17, DK – 8200 Aarhus N, Denmark

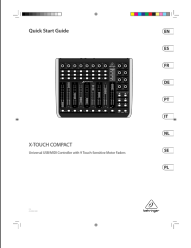
Documents / Resources

	<p>behringer X-TOUCH COMPACT Universal USB/MIDI Controller [pdf] User Guide X-TOUCH COMPACT Universal USB MIDI Controller, MIDI Controller with 9 Touch-Sensitive Motor Faders</p>
---	--

References

-  [Behringer | Home](#)
-  [Music Tribe](#)
-  [Music Tribe](#)