

# BANNER LCA130T Andon Control Box Instruction Manual

## Contents

- [1 LCA130T Andon Control Box with IO-Link](#)
  - [1.1 Instruction Manual](#)
    - [1.1.1 Chapter 1 Features](#)
      - [1.1.1.1 Models](#)
    - [1.1.2 Chapter 2 LCA130T Switch Diagram](#)
    - [1.1.3 Chapter 3 IO-Link Process Data Out \(Master to Device\)](#)
    - [1.1.4 Chapter 4 Specifications](#)
      - [1.1.4.1 FCC Part 15 Class B for Unintentional Radiators](#)
      - [1.1.4.2 Industry Canada ICES-003\(B\)](#)
      - [1.1.4.3 Dimensions](#)
    - [1.1.5 Chapter 5 Accessories](#)
      - [1.1.5.1 Cordsets](#)
      - [1.1.5.2 Power Supplies](#)
      - [1.1.5.3 IO-Link Masters](#)
    - [1.1.6 Chapter 6 Banner Engineering Corp Limited Warranty](#)
  - [2 Documents / Resources](#)
    - [2.1 References](#)
  - [3 Related Posts](#)

## LCA130T Andon Control Box with IO-Link

### Instruction Manual

Original Instructions  
p/n: 241973 Rev. A  
June 04, 2024  
© Banner Engineering Corp. All rights reserved.



### Chapter 1 Features

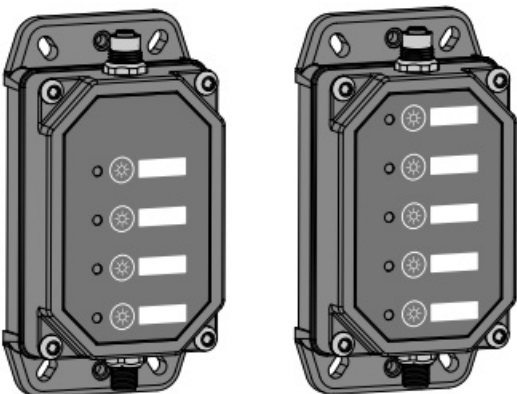

- Rugged, cost-effective, and easy-to-install Andon Control Box
- Integral three, four, or five capacitive touch button controller with programmable LEDs and discrete outputs
- IO-Link gives full access to color, flashing, and dimming settings, as well as advanced animations which provide dynamic response to changing machine conditions
- Two M12 connectors for added Andon application flexibility and easy installation
- Three to five discrete outputs available to pass up to a total of 4 amps

**Models**

Model Name	Activation Method	Number of Touch Buttons	Control	Connectors
LCA130T3 KQ	Touch	3 Buttons	IO-Link	Input: Integral 4-pin M12 male quick disconnect connector Output: Integral 5-pin M12 female quick-disconnect connector
LCA130T4 KQ		4 Buttons		Input: Integral 4-pin M12 male quick disconnect connector Output: Integral 5-pin M12 female quick-disconnect connector
LCA130T5 KQ		5 Buttons		Input: Integral 4-pin M12 male quick disconnect connector Output: Integral 8-pin M12 female quick-disconnect connector

**Chapter 2 LCA130T Switch Diagram**

Touch, or touch and hold, one or more of the buttons to activate a programmed color and animation function.

Input Pinout – All Models

4-pin M12 Male Connector	Pin	Wire Color	Wiring Description
	1	Brown (bn)	18 V DC to 30 V DC
	2	White (wh)	Not used
	3	Blue (bu)	DC common (GND)
	4	Black (bk)	IO-Link Communication

Output Pinout Switch Control

Button Diagrams	Connectors	Pinout Keys
-----------------	------------	-------------

**5-Button LCA130T**

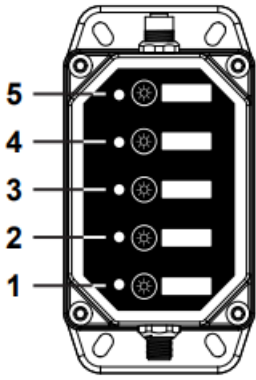

Button 1  
Button 2  
Button 3  
Button 4  
Button 5

**8-pin M12 Female Connector**

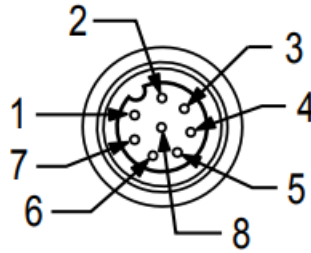

Pin 1 = Button 3  
Pin 2 = Button 4  
Pin 3 = Not used  
Pin 4 = Button 1  
Pin 5 = Button 2  
Pin 6 = Button 5  
Pin 7 = DC common (GND)  
Pin 8 = Not used

**4-Button LCA130T**

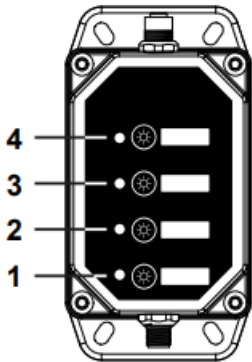

Button 1  
Button 2  
Button 3  
Button 4

**5-pin M12 Female Connector**

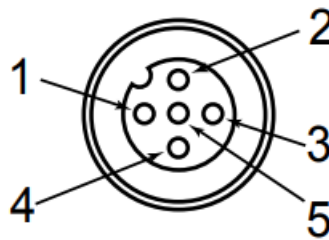

Pin 1 = Button 2  
Pin 2 = Button 3  
Pin 3 = DC common (GND)  
Pin 4 = Button 1  
Pin 5 = Button 4

**3-Button LCA130T**

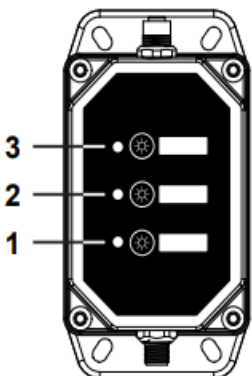

Button 1  
Button 2  
Button 3

**5-pin M12 Female Connector**

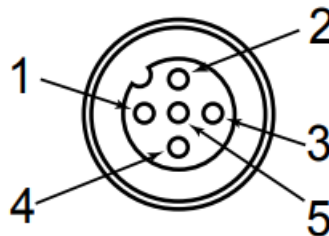

Pin 1 = Button 2  
Pin 2 = Button 3  
Pin 3 = DC common (GND)  
Pin 4 = Button 1  
Pin 5 = Not used

IO-Link® is a point-to-point communication link between a master device and a sensor and/or light. It can be used to automatically parameterize sensors or lights and to transmit process data. For the latest IO-Link protocol and specifications, please visit [www.io-link.com](http://www.io-link.com).

For the latest IODD files, please refer to the Banner Engineering Corp website at: [www.bannerengineering.com](http://www.bannerengineering.com).

### State Mode

Use Process Data In to read button output states of Off, On, or Hold.

Use Process Data Out to set button output states to No Override, Off, On, or Hold.

Use Parameter data to change touch button sensitivity, logic, color, intensity, flash speed, and select animation type on Off, On, and Hold output states.

Name	Description
<b>Animation Type</b>	
Off	Button LED is off
Steady	Color 1 is solid on at defined intensity
Flash	Color 1 flashes at defined speed, color intensity, and pattern
Two Color Flash	Color 1 and Color 2 flash alternately at defined speed, color intensities, and pattern
Intensity Sweep	Color 1 repeatedly increases and decreases intensity between 0% to 100% at defined speed and color intensity
Color Sweep	Color 1 and Color 2 transition alternately at defined speed and color intensities
<b>Animation Pattern</b>	Defines the flash pattern for flash and two color flash animations (normal, strobe, three pulse, SOS, or random)
<b>Animation Speed</b>	Defines the animation speed (slow, medium, fast, or custom)
<b>Off Delay Type</b>	Defines if the Off Delay should be measured from when the conditions for the State began (Leading Edge) or from when the conditions ended (Trailing Edge)
<b>Off Delay (ms)</b>	The duration of the animation Off Delay. Leading Edge Off Delays can be used to ensure the animation is active for at least a minimum amount of time.
<b>Color 1</b>	Defines Color 1 of defined animation
<b>Color 1 Intensity</b>	Defines the intensity of Color 1 in the animation (high, medium, low, off, or custom)
<b>Color 2</b>	Defines Color 2 of defined animation
<b>Color 2 Intensity</b>	Defines the intensity of Color 2 in the animation (high, medium, low, off, or custom)
<b>Touch Sensitivity</b>	Defines the sensitivity of the touch button as either Standard, High or Low. Low sensitivity resists false activation. High sensitivity can be used for improved touch response
<b>Function</b>	Latching or Momentary options. Momentary function toggles output on only during a touch button input. Latching function toggles output on or off for each touch button input
<b>Hold</b>	Defines if Hold state is Enabled or Disabled

## Advanced Mode

Use Process Data In to read button output states of True or False.

Use Process Data Out to set touch button logic, color, intensity, flash speed, and select animation type.

Name	Description
<b>Animation Type</b>	
Off	Button LED is off
Steady	Color 1 is solid on at defined intensity
Flash	Color 1 flashes at defined speed, color intensity, and pattern
Two Color Flash	Color 1 and Color 2 flash alternately at defined speed, color intensities, and pattern
Intensity Sweep	Color 1 repeatedly increases and decreases intensity between 0% to 100% at defined speed and color intensity
Color Sweep	Color 1 and Color 2 transition alternately at defined speed and color intensities
<b>Output</b>	Sets button output to On, Off, or Pattern
<b>Animation Pattern</b>	Defines the flash pattern for flash and two color flash animations (normal, strobe, three pulse, SOS, or random)
<b>Animation Speed</b>	Defines the animation speed (slow, medium, fast, or custom)
<b>Color 1</b>	Defines Color 1 of defined animation
<b>Color 1 Intensity</b>	Defines the intensity of Color 1 in the animation (high, medium, low, off, or custom)
<b>Color 2</b>	Defines Color 2 of defined animation
<b>Color 2 Intensity</b>	Defines the intensity of Color 2 in the animation (high, medium, low, off, or custom)

## Chapter 4 Specifications

### Supply Voltage and Current

18 V DC to 30 V DC

50 mA maximum current at 18 V DC (exclusive of load)

### Supply Protection Circuitry

Protected against transient voltages

### Response Time

Power-Up Delay: 500 milliseconds maximum

Input Response: 40 milliseconds maximum

Output Response: 300 milliseconds maximum

### IO-Link Interface

Supports Smart Sensor Profile: No

Baud Rate: 38400 bps (COM2)

Process Data In: 16 bits (2 bytes)

Process Data Out: 160 bits (20 bytes)

IODD Files: Provides all programming options, plus additional functionality

### Output Rating

4A maximum load (combined or on a single output)

### Connections

Inputs: Integral 4-pin M12 male quick-disconnect connector

Outputs: Integral 5-pin or 8-pin M12 female quick-disconnect connector, depending on model

Models with a quick disconnect require a mating cordset

### Construction

Polycarbonate

### Vibration and Mechanical Shock

Meets IEC 60068-2-6 requirements (Vibration: 10 Hz to 55 Hz, 0.5 mm amplitude, 5 minutes sweep, 30 minutes dwell)

Meets IEC 60068-2-27 requirements (Shock: 15G 11 ms duration, half sine wave)

### Operating Conditions

-40 °C to +50 °C (-40 °F to +122 °F)

95% at +50 °C maximum relative humidity (non-condensing)

### Environmental Rating

IP65

### Required Overcurrent Protection



**WARNING:** Electrical connections must be made by qualified personnel in accordance with local and national electrical codes and regulations.

Overcurrent protection is required to be provided by end product application per the supplied table.

Overcurrent protection may be provided with external fusing or via Current Limiting, Class 2 Power Supply.

Supply wiring leads < 24 AWG shall not be spliced.

For additional product support, go to [www.bannerengineering.com](http://www.bannerengineering.com).

Supply Wiring (AWG)	Required Overcurrent Protection (A)
20	5.0
22	3.0
24	1.0
26	1.0
28	0.8
30	0.5

## Certifications



Banner Engineering BV  
Park Lane, Culliganlaan 2F bus 3  
1831 Diegem, BELGIUM



Turck Banner LTD Blenheim House  
Blenheim Court  
Wickford, Essex SS11 8YT  
GREAT BRITAIN



### FCC Part 15 Class B for Unintentional Radiators

(Part 15.105(b)) This equipment has been tested and found to comply with the limits for a Class B digital device, pursuant to part 15 of the FCC Rules. These limits are designed to provide reasonable protection against harmful interference in a residential installation. This equipment generates, uses, and can radiate radio frequency energy and, if not installed and used in accordance with the instructions, may cause harmful interference to radio communications. However, there is no guarantee that interference will not occur in a particular installation. If this equipment does cause harmful interference to radio or television reception, which can be determined by turning the equipment off and on, the user is encouraged to try to correct the interference by one or more of the following measures:

- Reorient or relocate the receiving antenna.
- Increase the separation between the equipment and receiver.
- Connect the equipment into an outlet on a circuit different from that to which the receiver is connected.
- Consult the dealer or an experienced radio/TV technician for help.

(Part 15.21) Any changes or modifications not expressly approved by the party responsible for compliance could void the user's authority to operate this equipment.

### Industry Canada ICES-003(B)

This device complies with CAN ICES-3 (B)/NMB-3(B). Operation is subject to the following two conditions: 1) This device may not cause harmful interference; and 2) This device must accept any interference received, including interference that may cause undesired operation.

### Dimensions

All measurements are listed in millimeters [inches], unless noted otherwise.

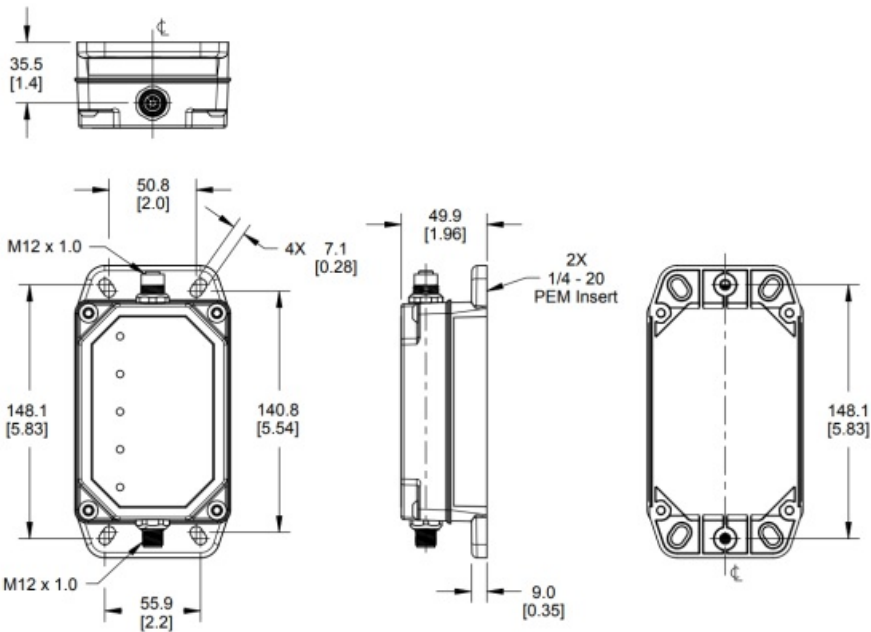

## Chapter 5 Accessories

### Cordsets

4-Pin Threaded M12 Cordsets—Single Ended				
Model	Length	Style	Dimensions	Pinout (Female)
<b>MQD C-403</b>	1 m (3.28 ft)	Straight		
<b>MQD C-406</b>	2 m (6.56 ft)			
<b>MQD C-410</b>	3 m (9.8 ft)			
<b>MQD C-415</b>	5 m (16.4 ft)			
<b>MQD C-430</b>	9 m (29.5 ft)			
<b>MQD C-450</b>	15 m (49.2 ft)			
<b>MQD C-460</b>	18.3 m (60 ft)			
<b>MQD C-470</b>	21 m (68.9 ft)			
<b>MQD C-4100</b>	30 m (98.43 ft)			



### 5-Pin Threaded M12 Cordsets—Double Ended

Model	Length	Style	Dimensions	Pinout (Male)	Pinout (Female)
MQDEC-501SS	0.31 m (1.02 ft)	Male Straight/ Female Straight			
MQDEC-503SS	0.91 m (2.99 ft)				
MQDEC-506SS	1.83 m (6 ft)				
MQDEC-512SS	3.66 m (12 ft)				
MQDEC-515SS	5 m (16.4 ft)				
MQDEC-530SS	9 m (29.5 ft)				
MQDEC-550SS	15 m (49.2 ft)				
				1 = Brown 2 = White 3 = Blue	4 = Black 5 = Gray

### 8-Pin Threaded M12 Cordsets—Double Ended

Model	Length	Style	Dimensions	Pinout
MQDEC1-803SS	1 m (3.28 ft)	Male Straight / Female Straight		1 = White 2 = Brown 3 = Green 4 = Yellow 5 = Gray 6 = Pink 7 = Blue 8 = Red
MQDEC1-806SS	2 m (6.56 ft)			
MQDEC1-810SS	3 m (9.84 ft)			
MQDEC1-815SS	5 m (16.4 ft)			
MQDEC1-830SS	9 m (29.5 ft)		<div style="display: flex; justify-content: space-around;"> <div style="text-align: center;"> <p>Female</p> </div> <div style="text-align: center;"> <p>Male</p> </div> </div>	
MQDEC1-850SS	15 m (49.2 ft)			
MQDEC1-8100SS	30.5 m (100 ft)			
MQDEC1-8200SS	61 m (200 ft)			

## CSB-M1251FM1251M

- 5-pin parallel Y splitter (Male-Male-Female)
- For full Pro Editor preview capability
- Requires external power supply, sold separately

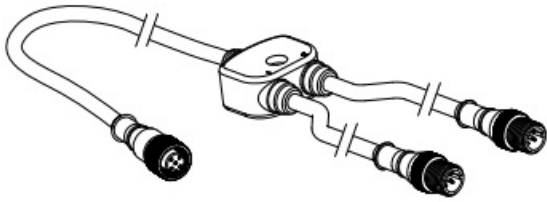

## Power Supplies

### PSW-24-1

- 24 V DC, 1 A Class 2 UL Listed power supply
- 100 V AC to 240 V AC 50/60 Hz input
- 2 m (6.5 ft) PVC cable with M12 quick disconnect
- Includes Type A (US, Canada, Japan, Puerto Rico, Taiwan), Type C (Germany, France, South Korea, Netherlands, Poland, Spain, Turkey), Type G (United Kingdom, Ireland, Singapore, Vietnam), and Type I (China, Australia, New Zealand) AC detachable input plugs



### PSW-24-2

- 24 V DC, 2 A Class 2 UL Listed power supply
- 100 V AC to 240 V AC 50/60 Hz input
- 3.5 m (11.5 ft) PVC cable with M12 quick disconnect
- Includes Type A (US, Canada, Japan, Puerto Rico, Taiwan), Type C (Germany, France, South Korea, Netherlands, Poland, Spain, Turkey), Type G (United Kingdom, Ireland, Singapore, Vietnam), and Type I (China, Australia, New Zealand) AC detachable input plugs

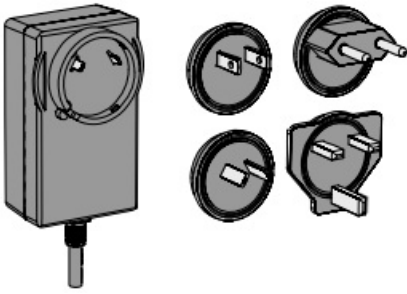

**IO-Link Masters**

**DXMR90-4K Series Controller IO-Link Master**

- One female M12 D-Code Ethernet connector
- Four female M12 connections for IO-Link master connections
- One male M12 (Port 0) connection for incoming power and Modbus RS-485, one female M12 connection for daisy chaining Port 0 signals

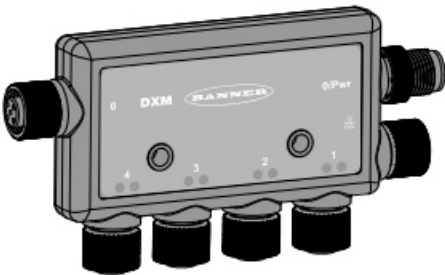

**DXMR110-8K Series Controller IO-Link Master**

- Two female M12 D-Code Ethernet connectors for daisy chaining and communication to a higher-level control system
- Eight female M12 connections for IO-Link master connections
- One male M12 connection for incoming power, one female M12 connection for daisy chaining power

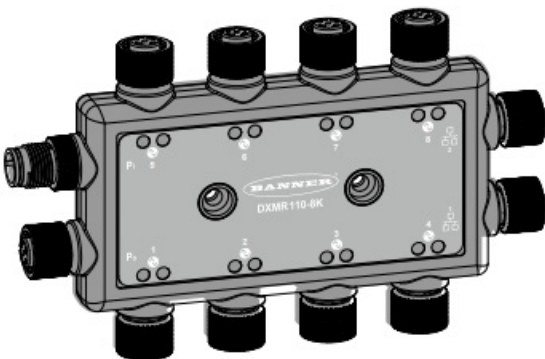

**Chapter 6 Banner Engineering Corp Limited Warranty**

Banner Engineering Corp. warrants its products to be free from defects in material and workmanship for one year following the date of shipment. Banner Engineering Corp. will repair or replace, free of charge, any product of its manufacture which, at the time it is returned to the factory, is found to have been defective during the warranty period. This warranty does not cover damage or liability for misuse, abuse, or the improper application or

installation of the Banner product.

**THIS LIMITED WARRANTY IS EXCLUSIVE AND IN LIEU OF ALL OTHER WARRANTIES WHETHER EXPRESS OR IMPLIED (INCLUDING, WITHOUT LIMITATION, ANY WARRANTY OF MERCHANTABILITY OR FITNESS FOR A PARTICULAR PURPOSE), AND WHETHER ARISING UNDER COURSE OF PERFORMANCE, COURSE OF DEALING OR TRADE USAGE.**

This Warranty is exclusive and limited to repair or, at the discretion of Banner Engineering Corp., replacement. **IN NO EVENT SHALL BANNER ENGINEERING CORP. BE LIABLE TO BUYER OR ANY OTHER PERSON OR ENTITY FOR ANY EXTRA COSTS, EXPENSES, LOSSES, LOSS OF PROFITS, OR ANY INCIDENTAL, CONSEQUENTIAL OR SPECIAL DAMAGES RESULTING FROM ANY PRODUCT DEFECT OR FROM THE USE OR INABILITY TO USE THE PRODUCT, WHETHER ARISING IN CONTRACT OR WARRANTY, STATUTE, TORT, STRICT LIABILITY, NEGLIGENCE, OR OTHERWISE.**

Banner Engineering Corp. reserves the right to change, modify or improve the design of the product without assuming any obligations or liabilities relating to any product previously manufactured by Banner Engineering Corp. Any misuse, abuse, or improper application or installation of this product or use of the product for personal protection applications when the product is identified as not intended for such purposes will void the product warranty. Any modifications to this product without prior express approval by Banner Engineering Corp will void the product warranties. All specifications published in this document are subject to change; Banner reserves the right to modify product specifications or update documentation at any time. Specifications and product information in English supersede that which is provided in any other language. For the most recent version of any documentation, refer to: [www.bannerengineering.com](http://www.bannerengineering.com).

For patent information, see [www.bannerengineering.com/patents](http://www.bannerengineering.com/patents).

June 04, 2024

© Banner Engineering Corp. All rights reserved.



[LinkedIn](#)



[Twitter](#)



[Facebook](#)



© 2024. All rights reserved.

[www.bannerengineering.com](http://www.bannerengineering.com)

**Documents / Resources**

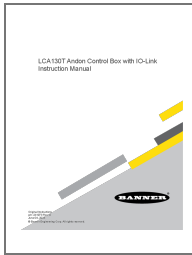

**[BANNER LCA130T Andon Control Box](#)** [pdf] Instruction Manual  
LCA130T5KQ, LCA130T, LCA130T Andon Control Box, LCA130T, Andon Control Box, Control Box, Box

**References**

- [Banner Engineering | Smarter Automation. Better Solutions.](#)
- [Patents](#)
- [Banner Engineering | Smarter Automation. Better Solutions.](#)
- [User Manual](#)

[Manuals+](#), [Privacy Policy](#)

This website is an independent publication and is neither affiliated with nor endorsed by any of the trademark owners. The "Bluetooth®" word mark and logos are registered trademarks owned by Bluetooth SIG, Inc. The "Wi-Fi®" word mark and logos are registered trademarks owned by the Wi-Fi Alliance. Any use of these marks on this website does not imply any affiliation with or endorsement.