

[Manuals.plus](#) /

› [VEVOR](#) /

› VEVOR 5L Horizontal Manual Sausage Stuffer Instruction Manual

## VEVOR Pousoir à Saucisse 5L

# VEVOR 5L Horizontal Manual Sausage Stuffer

Instruction Manual

## INTRODUCTION

---

This manual provides detailed instructions for the safe and efficient operation, maintenance, and care of your VEVOR 5L Horizontal Manual Sausage Stuffer. Please read this manual thoroughly before initial use to ensure proper function and to prevent damage to the unit or injury.

# HORIZONTAL SAUSAGE MAKER

Make Your Own Tasty and Fresh Sausage



Fast & Efficient



Easy to Clean



Image: The VEVOR 5L Horizontal Manual Sausage Stuffer in operation, demonstrating its use for making fresh sausages. The image highlights its efficiency and ease of cleaning.

## SAFETY INSTRUCTIONS

- Always ensure the sausage stuffer is placed on a stable, flat, and non-slip surface before operation.
- Keep hands and fingers clear of moving parts, especially the plunger and stuffing tube, during operation.
- Do not overload the cylinder with meat mixture.
- Ensure all components are correctly assembled and secured before use.
- Clean all parts thoroughly before first use and after each subsequent use to maintain hygiene and prevent bacterial growth.
- Store the appliance out of reach of children.
- Use only food-grade ingredients and casings.

## PRODUCT OVERVIEW AND COMPONENTS

The VEVOR 5L Horizontal Manual Sausage Stuffer is constructed from food-grade 304 stainless steel, ensuring durability and hygiene. Key components include:

- **Cylinder:** Holds the meat mixture.
- **Plunger/Pressure Plate:** Pushes the meat through the stuffing tube.
- **Stuffing Tubes:** Various sizes for different sausage types.
- **Crank Handle:** Operates the plunger mechanism.
- **Gear System:** Allows for dual-speed operation (fast and slow).
- **Base:** Provides stability for the unit.



Image: Detailed view of the VEVOR 5L Horizontal Manual Sausage Stuffer, illustrating its full 304 stainless steel construction and key parts like the discharge port, silicone sealing ring, fixed nut, integrated pressure plate, and ergonomic handle.

## SETUP

1. **Unpack and Inspect:** Carefully remove all components from the packaging. Inspect for any damage.
2. **Initial Cleaning:** Wash all parts that will come into contact with food (cylinder, plunger, stuffing tubes) with warm, soapy water. Rinse thoroughly and dry completely.
3. **Assemble the Base:** Place the main body of the stuffer on a stable, clean countertop.
4. **Attach Stuffing Tube:** Select the desired stuffing tube size ( $\Phi 10$  mm,  $\Phi 16$  mm,  $\Phi 22$  mm,  $\Phi 32$  mm, or  $\Phi 38$  mm) and securely attach it to the discharge port.
5. **Prepare Cylinder:** Ensure the cylinder is clean and properly seated in its position.



Image: A display of the five stainless steel stuffing tubes included with the VEVOR sausage stuffer, showing their varying diameters (0.4", 0.6", 0.87", 1.26", 1.5") to accommodate different sausage sizes.

## OPERATING INSTRUCTIONS

1. **Load Meat Mixture:** Tilt the cylinder upwards and fill it with your prepared meat mixture. Ensure the mixture is evenly distributed and not packed too tightly. The 5L capacity allows for a substantial amount of meat.
2. **Secure Cylinder:** Lower and secure the cylinder back into its horizontal position.
3. **Prepare Casing:** Slide the desired sausage casing onto the stuffing tube, gathering it at the base.
4. **Begin Stuffing:** Turn the crank handle. The dual-speed gear system allows you to choose between a fast speed for quickly advancing the plunger and a slow speed for controlled stuffing. Use the slow speed for precise filling to avoid air pockets.
5. **Form Sausages:** As the meat fills the casing, gently guide it off the tube. Twist or tie the casing at desired intervals to form individual sausages.
6. **Continue Stuffing:** Repeat the process until all meat mixture is used.



Image: The VEVOR 5L Horizontal Manual Sausage Stuffer demonstrating its horizontal design, ergonomic handle, and dual-speed settings (Fast Speed and Slow Speed) for efficient and controlled operation.

## MAINTENANCE AND CLEANING

Regular cleaning and maintenance are crucial for the longevity and hygienic operation of your sausage stuffer.

1. **Disassembly:** After each use, completely disassemble the cylinder, plunger, and stuffing tubes.
2. **Washing:** Wash all disassembled parts immediately with warm water and a mild dish soap. Use a brush to remove any meat residue.
3. **Rinsing:** Rinse all parts thoroughly under running water to remove all soap residue.
4. **Drying:** Dry all components completely with a clean cloth or allow them to air dry before reassembly or storage. This prevents water spots and potential corrosion.
5. **Lubrication (Optional):** Apply a thin layer of food-grade mineral oil to the plunger's silicone seal and the gear mechanism periodically to ensure smooth operation and prevent wear.
6. **Storage:** Store the clean and dry sausage stuffer in a clean, dry place.

**LARGE STORAGE AND EFFORTLESS TO CLEAN**

**Satisfy the Whole Family & Save Cleaning Effort**

Removable Cylinder

5L Meat

Image: The VEVOR 5L Horizontal Manual Sausage Stuffer highlighting its large 5L capacity and removable cylinder design, which facilitates easy and effortless cleaning after use.

## TROUBLESHOOTING

Problem	Possible Cause	Solution
Meat not extruding smoothly.	Meat mixture is too dry or too coarse; air pockets in the cylinder.	Add a small amount of liquid (water, broth) to the meat mixture; ensure meat is finely ground; pack the cylinder firmly to remove air.
Casing breaks during stuffing.	Casing is overfilled; casing is dry or old; too much pressure.	Reduce stuffing speed; moisten casings before use; use fresh casings; reduce pressure by using the slow speed setting.
Crank handle is difficult to turn.	Meat mixture is too dense; plunger seal is dry; gears need lubrication.	Adjust meat mixture consistency; lubricate the plunger seal with food-grade oil; lubricate gears with food-grade grease.
Air pockets in sausages.	Air trapped in the meat mixture or cylinder during loading.	Pack meat mixture tightly into the cylinder, ensuring no large air gaps; use a slower stuffing speed.

## SPECIFICATIONS

Feature	Detail
Brand	VEVOR
Model Number	Poussoir à Saucisse 5L
Capacity	5 Liters (approx. 11 lbs)
Material	Food-Grade 304 Stainless Steel
Operation	Manual, Dual-Speed Gear System
Stuffing Tubes Included	5 sizes: $\Phi$ 10 mm (0.4"), $\Phi$ 16 mm (0.6"), $\Phi$ 22 mm (0.87"), $\Phi$ 32 mm (1.26"), $\Phi$ 38 mm (1.5")
Product Weight	23.1 lbs (10.5 kg)
Product Dimensions (L x W x H)	Approx. 22 in x 8.3 in x 8.6 in (55.9 cm x 21.1 cm x 21.8 cm)
Color	Silver
UPC	197988073024
Country of Origin	China

# PRODUCT SPECIFICATIONS:

# VEVOR®

Product Weight: 23.1 lbs / 10.5 kg

Product Size: 22 in x 8.3 in x 8.6 in / 55.9 cm x 21.1 cm x 21.8 cm

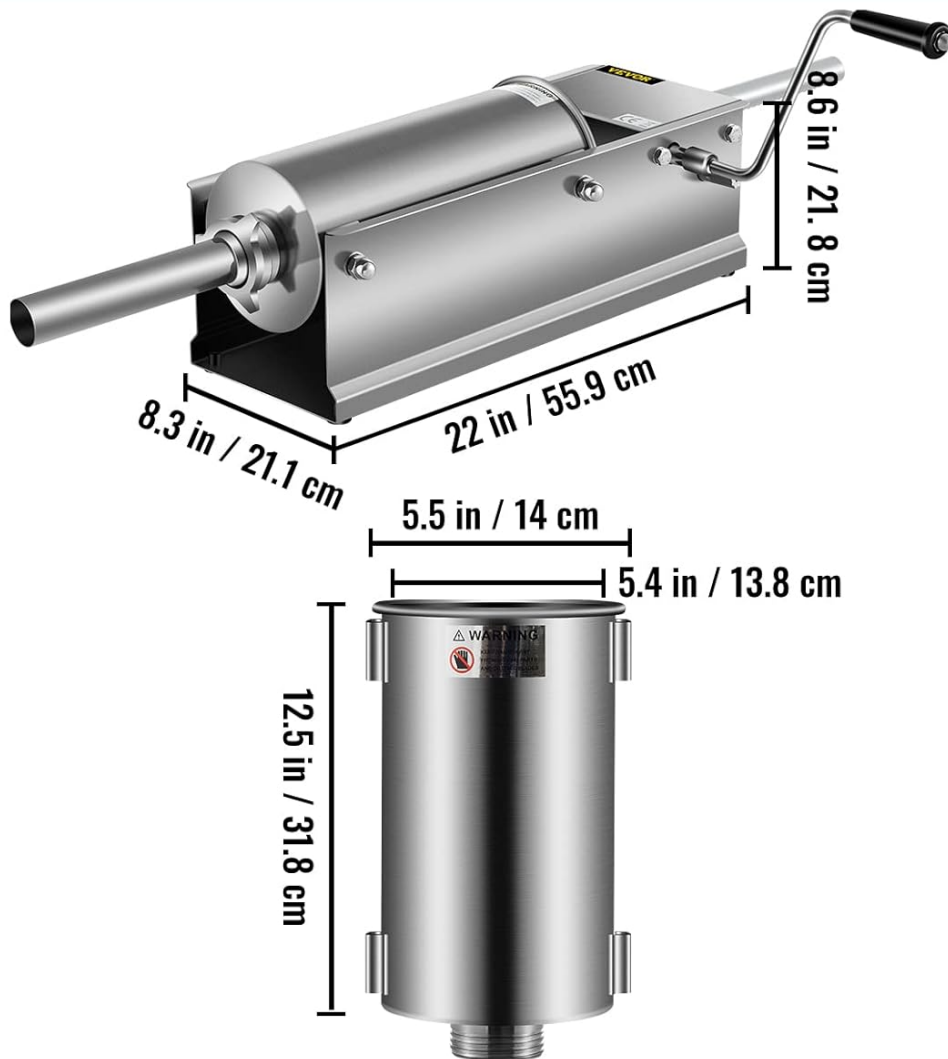

Image: Product specifications including weight (23.1 lbs / 10.5 kg) and overall dimensions (22 in x 8.3 in x 8.6 in / 55.9 cm x 21.1 cm x 21.8 cm) for the VEVOR 5L Horizontal Manual Sausage Stuffer.

## WARRANTY AND SUPPORT

For warranty information or technical support, please refer to the documentation included with your purchase or visit the official VEVOR website. Keep your purchase receipt as proof of purchase for any warranty claims.

You can also visit the [VEVOR Brand Store on Amazon](#) for more product information and support resources.

