



[Manuals.plus](#) /

› [Homiflex](#) /

› Homiflex 16-in-1 Cat Wall Shelves User Manual

Homiflex MAHfler2wx4

Homiflex 16-in-1 Cat Wall Shelves

USER MANUAL

Introduction

This manual provides detailed instructions for the assembly, installation, and maintenance of your Homiflex 16-in-1 Cat Wall Shelves. Please read all instructions carefully before beginning installation to ensure proper setup and safe use for your cats.

Package Contents

Verify that all components listed below are present in your package. If any parts are missing or damaged, please contact customer support.

PRODUCT SIZE

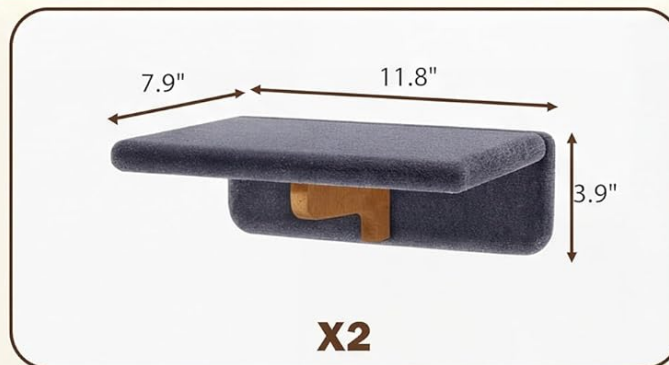
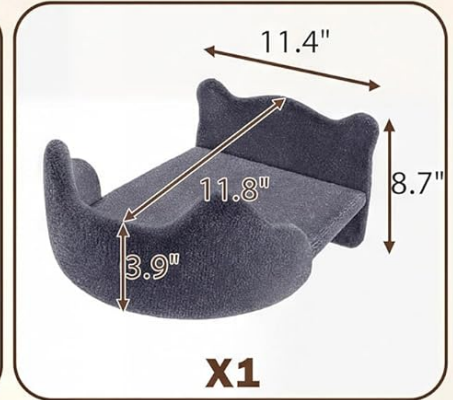
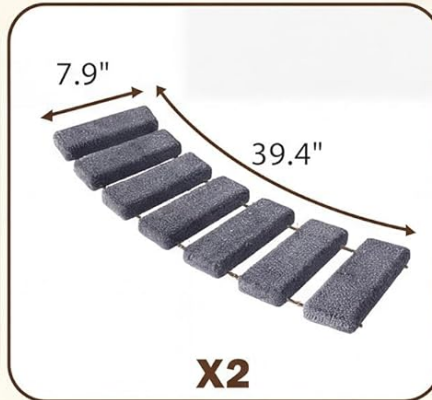
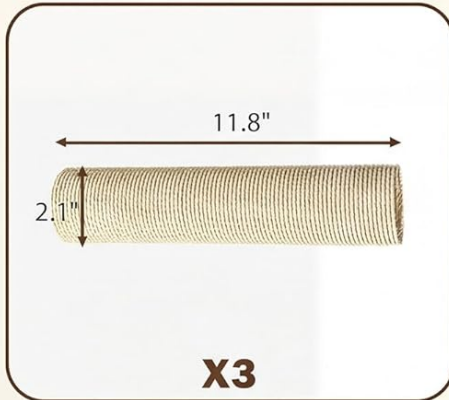
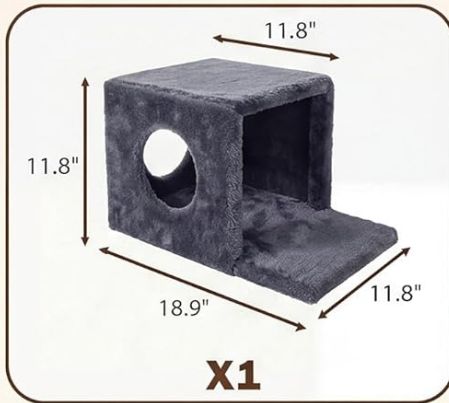

Image: Overview of all 16 components with their respective dimensions and quantities.

- 1 x Cat House (18.9"L x 11.8"W x 11.8"H)
- 6 x Cat Ear Shaped Shelves (11.4"L x 8.7"H)
- 1 x 40"L Tunnel (39.4"L x 6.9"H x 5.3"W)
- 3 x Scratching Posts (11.8"L x 2.1" diameter)
- 2 x Bridge Ladders (39.4"L x 7.9"W)
- 1 x Curved Shelf (11.8"L x 8.7"H x 3.9"W)
- 2 x Flat Shelves (11.8"L x 7.9"W x 3.9"H)
- 1 x Accessory Kit (includes screws, wall anchors, and tools)
- 1 x Instructions Manual

Key Features

- **Soft Plush Fabric:** Provides a comfortable resting surface for cats.

- **16-in-1 Modular Design:** Allows for customizable configurations to create a unique climbing system.
- **Space-Saving:** Wall-mounted design maximizes vertical space, ideal for small homes or multiple cats.
- **Multi-Cat Friendly:** Multiple spacious shelves, condos, and tunnels accommodate several cats.
- **Durable Construction:** Made with engineered wood and natural sisal rope for stability and longevity.

DESIGNED FOR YOUR CAT'S PLEASURE

PARTICLE BOARD

Made with sustainable, safe materials to ensure total safety during playtime



SOFT PLUSH COVERING

Through the densely woven plush fabric, your cat experiences unmatched coziness

NATURAL SISAL ROPE

Durable sisal rope is very resilient yet strong enough to withstand constant scratches, satisfying the instincts of your restless kitten



Image: Detailed view of the materials used: particle board, soft plush fabric, and natural sisal rope.

Designed to Accommodate

up
to **40 LBS**



Image: Illustrates the weight capacity of the shelves, designed to accommodate cats up to 40 lbs total, with individual shelves supporting up to 20 lbs.

Installation Guide

Follow these steps for secure installation. It is recommended to have two people for certain steps.

1. **Plan Your Layout:** Before drilling, determine the desired arrangement of the shelves on your wall. Consider your cat's movement patterns and preferred resting spots. Ensure adequate spacing between components.
2. **Identify Wall Studs:** For maximum stability, mount components directly into wall studs using a stud finder. If studs are not available, use the provided wall anchors suitable for your wall type (e.g., drywall, concrete).
3. **Mark Drill Points:** Hold each component against the wall at its intended location and mark the screw holes with a pencil.
4. **Drill Pilot Holes:** Drill pilot holes at the marked locations. The size of the drill bit should match the recommended size for the screws and anchors.

5. **Insert Wall Anchors (if needed):** If not drilling into studs, insert the appropriate wall anchors into the pilot holes.
6. **Attach Components:** Securely fasten each shelf, tunnel, or scratching post to the wall using the provided screws. Ensure all connections are tight and stable.
7. **Assemble Bridges and Tunnels:** Connect bridge ladders and the tunnel between shelves as per your planned layout, ensuring they are securely attached and stable for your cat's movement.
8. **Final Check:** Once all components are installed, gently test each piece for stability and ensure there are no loose parts.



Image: Example of a complete installation of the cat wall system in a home environment.

Usage and Operation

The Homiflex 16-in-1 Cat Wall Shelves are designed to provide an enriching vertical environment for your feline companions. Cats can use the various elements for climbing, jumping, scratching, and resting.

- **Climbing and Jumping:** The multi-level shelves and steps encourage natural climbing behavior, allowing cats to

explore their environment from a higher vantage point.

- **Scratching:** The sisal rope scratching posts provide an appropriate outlet for scratching, helping to protect your furniture.
- **Resting and Hiding:** The plush-covered shelves, cat house, and tunnel offer cozy spots for napping, observing, or seeking solitude.
- **Interactive Play:** The interconnected design, including bridge ladders and tunnels, promotes active play and exercise.



Image: Cats actively engaging with the wall-mounted system, showcasing its use for jumping and exploration.

MULTI-PLATFORM CAT ZONE FOR PEACEFUL RESTING



Image: Cats utilizing the various platforms and the tunnel for peaceful resting and observation.

Care and Maintenance

Regular maintenance will ensure the longevity and safety of your cat wall system.

- **Cleaning Plush Surfaces:** Use a lint roller or a vacuum cleaner with a brush attachment to remove loose fur and debris from the plush fabric. For spot cleaning, use a damp cloth with mild soap and water, then air dry completely. Avoid harsh chemicals.
- **Inspecting Components:** Periodically check all screws and connections to ensure they remain tight. Retighten if necessary. Inspect the sisal scratching posts for wear and tear; replace if heavily damaged to maintain effectiveness and safety.
- **Wall Stability:** Regularly check the wall mounts for any signs of loosening or damage. Address any issues promptly to prevent accidents.

Troubleshooting Common Issues

Issue	Possible Cause	Solution
Shelves feel unstable or wobbly.	Loose screws or improper wall anchors.	Ensure all screws are tightened. If not mounted into studs, verify that appropriate wall anchors were used and installed correctly. Consider relocating to a stud if possible.
Cat is not using the system.	New environment, unfamiliarity, or preference for other areas.	Encourage your cat with treats, toys, or catnip on the shelves. Place familiar bedding on platforms. Allow time for your cat to adjust.
Scratching posts are not being used.	Cat prefers a different scratching material or orientation.	Apply catnip to the sisal posts. Demonstrate scratching by gently guiding your cat's paws. Ensure posts are stable and at a comfortable height.
Missing parts during unboxing.	Packaging error.	Contact Homiflex customer support immediately with your purchase details.

Product Specifications

Attribute	Detail
Model Number	MAHfler2wx4
Product Dimensions (Overall)	94.49"L x 11.81"W x 78.74"H (approximate, customizable layout)
Item Weight	41.88 Pounds
Material	Engineered Wood, Plush Fabric, Natural Sisal Rope
Mounting Type	Wall Mount
Color	Grey
Breed Recommendation	Cat
Specific Uses For Product	Climbing, Jumping, Running, Scratching, Resting

Safety Information

- Ensure the product is securely mounted to a sturdy wall structure. Improper installation can lead to injury to pets or damage to property.
- Regularly inspect all components for wear, damage, or loose connections. Tighten screws and replace damaged parts as needed.
- Do not exceed the recommended weight capacity of the individual shelves or the overall system.
- Keep small children away from the installation area during assembly and ensure they do not climb on the cat furniture.
- This product is designed for cats. Do not allow other pets or animals to use the system.

Warranty and Customer Support

Homiflex products are designed for quality and durability. For warranty information, missing parts, or any questions regarding your 16-in-1 Cat Wall Shelves, please refer to the contact information provided with your purchase or visit the official Homiflex website for customer support.

