

ZIPRO JumpPro Quadro 14FT

ZIPRO JumpPro Quadro 14FT Rectangular Trampoline User Manual

Model: JumpPro Quadro 14FT | Brand: ZIPRO



1. INTRODUCTION

This manual provides essential information for the safe assembly, operation, and maintenance of your ZIPRO JumpPro Quadro 14FT Rectangular Trampoline. Please read all instructions carefully before assembly and use to ensure safety and prolong the life of your product.

2. SAFETY INFORMATION

Your safety is paramount. Failure to follow these safety guidelines may result in serious injury.

- **Maximum User Weight:** The trampoline is designed to support a maximum user weight of 150 kg. Do not exceed this limit.
- **One User at a Time:** Only one person should use the trampoline at any given time to prevent collisions.
- **Adult Supervision:** Children must always be supervised by a responsible adult while using the trampoline.
- **Clearance Area:** Ensure a clear space of at least 2 meters around the trampoline on all sides and above.
- **No Somersaults or Flips:** Avoid somersaults, flips, or other dangerous maneuvers unless properly trained and supervised.
- **Inspect Before Each Use:** Before each use, check the trampoline for damaged, worn, or missing parts. Do not use if any components are compromised.
- **Weather Conditions:** Do not use the trampoline in strong winds, rain, or other adverse weather conditions. Secure the trampoline during strong winds.
- **No Hard Objects:** Do not bring hard or sharp objects onto the trampoline.
- **Proper Entry and Exit:** Always use the provided ladder for safe entry and exit. Do not jump on or off the trampoline.

- **Safety Enclosure:** The safety net must always be properly installed and closed during use.



Image: The ZIPRO JumpPro Quadro 14FT Rectangular Trampoline set up in a garden, showing children actively using it and adults nearby. This illustrates the trampoline's intended use in a family setting.

3. COMPONENTS LIST

Before assembly, verify that all parts are present and undamaged. Refer to the packaging diagrams for a visual representation of components.

- Rectangular Steel Frame Sections (Galvanized and Painted)
- Jumping Mat (Black, UV and weather resistant)
- Safety Enclosure Net (Tight mesh, double closure)
- Padded Poles for Safety Net
- Springs (72 units, 178 mm x 3.2 mm)
- Spring Cover Pad (EPE, PVC, PE materials)
- Ladder (80 cm height)

- Assembly Hardware (Bolts, nuts, tools if included)

Excellente élasticité du tapis



Image: A close-up view of the trampoline's springs and the edge of the jumping mat, illustrating the quantity of springs (72 units, 178 mm x 3.2 mm) and the robust connection that provides excellent elasticity for the jumping surface.



Image: A detailed technical diagram illustrating the overall dimensions of the ZIPRO JumpPro Quadro 14FT trampoline (427 cm L x 250 cm W x 260 cm H) and the packaging details, including weights of 37 kg and 42.5 kg for the two boxes.

4. SETUP AND ASSEMBLY INSTRUCTIONS

Assembly typically takes approximately 30 minutes with two adults. Follow these steps carefully.

1. **Prepare the Area:** Choose a flat, level outdoor surface free from obstacles, overhead wires, and hard surfaces.
2. **Assemble the Base Frame:** Connect the rectangular steel frame sections according to the diagrams. Ensure all connections are secure and click into place. The frame features quick and reinforced connections.
3. **Attach the Legs:** Securely attach the U-shaped legs to the main frame.
4. **Install the Jumping Mat:** Lay the jumping mat in the center of the frame. Begin attaching the springs evenly around the frame, connecting the mat to the frame. Use the provided spring tool if available.
5. **Place the Spring Cover Pad:** Once all springs are attached, cover them with the protective spring pad. Ensure it fully covers the springs and frame.
6. **Assemble Safety Net Poles:** Assemble the padded poles for the safety net.
7. **Install Safety Net:** Attach the safety net to the poles and secure it to the trampoline frame. Ensure the net is taut and the entrance zipper/closure system functions correctly.

8. **Attach Ladder:** Hook the 80 cm ladder onto the trampoline frame for safe access.
9. **Final Inspection:** Double-check all connections, springs, and the safety net for proper installation and security before first use.

Structure résistante à la corrosion

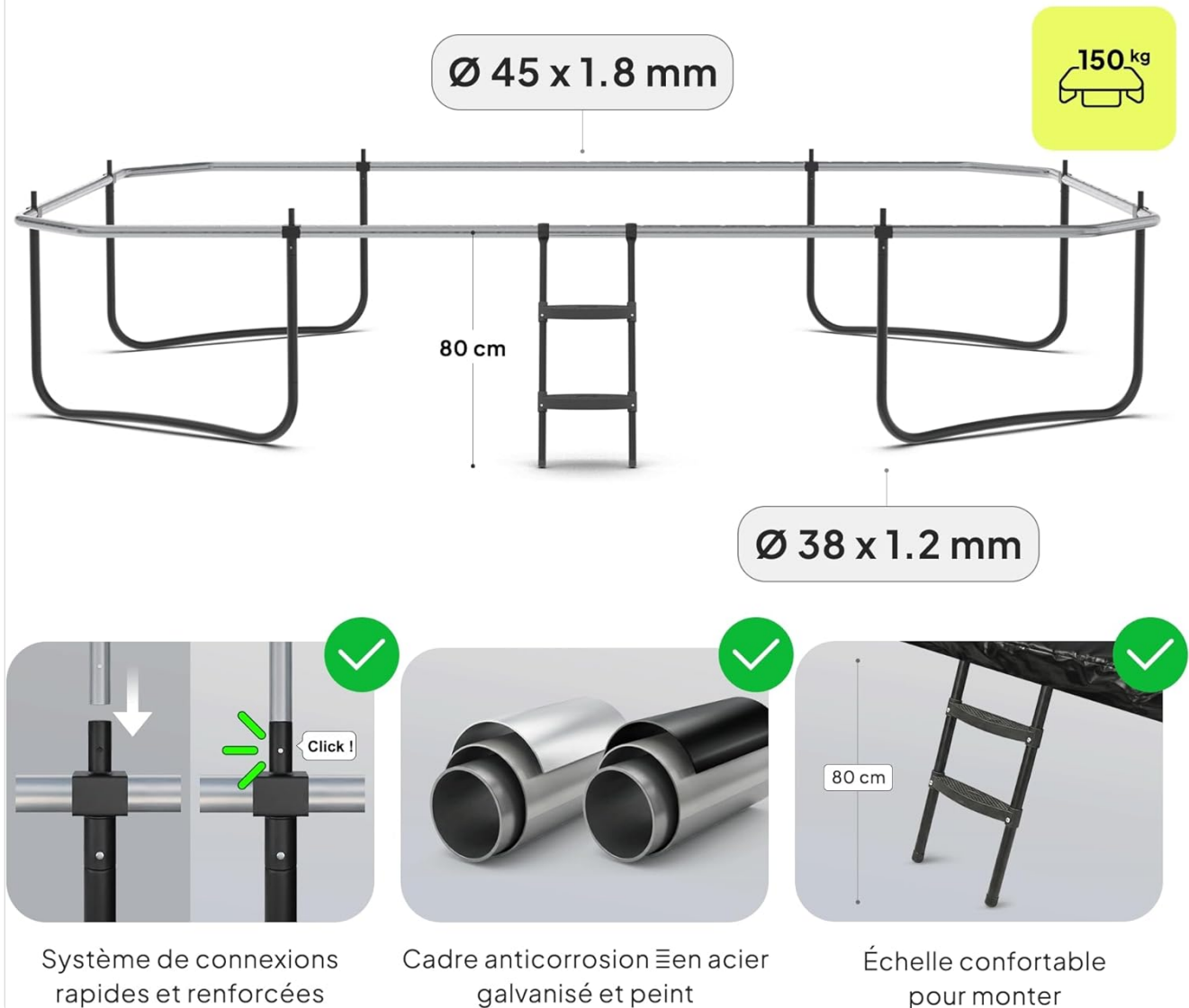

Image: A technical illustration detailing the trampoline's corrosion-resistant frame construction, featuring quick and reinforced connection points (indicated by "Click!"), galvanized and painted steel tubes ($\varnothing 45 \times 1.8 \text{ mm}$ and $\varnothing 38 \times 1.2 \text{ mm}$), and the 80 cm high access ladder.

5. OPERATING INSTRUCTIONS

To ensure a safe and enjoyable experience, follow these operating guidelines:

- **Enter Safely:** Always use the ladder to climb onto the trampoline.
- **Close Net:** Ensure the safety net entrance is securely closed before jumping.
- **Jump Responsibly:** Bounce in the center of the mat. Avoid jumping too high or attempting stunts beyond your skill level.
- **Exit Safely:** Stop bouncing completely before using the ladder to exit the trampoline.
- **Supervision:** Always supervise children.

- **Weather:** Do not use during rain, strong winds, or lightning.



Image: A child actively jumping on the ZIPRO JumpPro Quadro 14FT trampoline, demonstrating its use for active play and emphasizing the large jumping surface.

6. MAINTENANCE

Regular maintenance will extend the life of your trampoline and ensure continued safety.

- **Daily Checks:** Before each use, inspect the jumping mat, springs, frame, and safety net for any signs of wear, tears, or damage.
- **Cleaning:** Clean the jumping mat and safety net with mild soap and water. Rinse thoroughly and allow to air dry. Do not use abrasive cleaners.
- **Frame Inspection:** Periodically check all frame connections and bolts to ensure they are tight.
- **Springs:** Inspect springs for stretching, rust, or breakage. Replace any damaged springs immediately.
- **Safety Net:** Check the safety net for holes or tears. Ensure the zipper/closure mechanism is fully functional.
- **Weather Protection:** During prolonged periods of non-use or severe weather, consider disassembling and storing the trampoline indoors, or using a weather cover (not included). The materials are weather-resistant,

but protection extends lifespan.



**Matériaux de haute qualité
résistants aux intempéries**

Image: The ZIPRO JumpPro Quadro 14FT trampoline depicted in both sunny and rainy conditions, highlighting its construction with high-quality, weather-resistant materials (EPE, PVC, PE) designed to withstand outdoor elements.

7. TROUBLESHOOTING

Here are solutions to common issues you might encounter:

Problem	Possible Cause	Solution
Trampoline feels unstable.	Uneven ground; loose frame connections.	Relocate to a level surface. Check and tighten all frame bolts.
Jumping mat has reduced bounce.	Stretched or broken springs; worn mat.	Inspect all springs and replace any damaged ones. Consider replacing the mat if significantly worn.
Safety net is sagging or torn.	Loose attachments; material damage.	Re-secure net attachments to poles and frame. Repair small tears with a patch kit or replace the net if damage is extensive.

Problem	Possible Cause	Solution
Squeaking noises during use.	Friction between metal parts; dry springs.	Apply a silicone-based lubricant to frame joints and spring hooks.

8. SPECIFICATIONS

Feature	Detail
Model Name	JumpPro Quadro 14FT
Product Dimensions (L x W x H)	427 cm x 250 cm x 260 cm (Total Height)
Jumping Surface Dimensions	376 cm x 189 cm
Maximum User Weight	150 kg
Frame Material	Galvanized and Painted Steel (Ø 45 x 1.8 mm, Ø 38 x 1.2 mm)
Jumping Mat Material	Polyethylene (PE)
Springs	72 units, 178 mm x 3.2 mm
Safety Net Height	180 cm (from jumping mat)
Ladder Height	80 cm
Approximate Assembly Time	30 minutes (with two adults)
Color	Black
ASIN	B0GSC45SWY
Model Number	15521890



Image: A top-down view of the ZIPRO JumpPro Quadro 14FT trampoline, clearly indicating the jumping surface dimensions: 376 cm in length and 189 cm in width. A child is shown relaxing on the mat, providing a sense of scale.

9. WARRANTY AND SUPPORT

Your ZIPRO JumpPro Quadro 14FT Trampoline comes with a **one-year manufacturer's warranty** from the date of purchase. This warranty covers defects in materials and workmanship under normal use.

The warranty does not cover damage caused by improper assembly, misuse, neglect, accidents, unauthorized modifications, or normal wear and tear. Please retain your proof of purchase for warranty claims.

For warranty service, replacement parts, or technical support, please contact ZIPRO customer service through your retailer or the official ZIPRO website. Provide your model number (JumpPro Quadro 14FT) and ASIN (B0GSC45SWY) when contacting support.

