

## HOSTACK 257

# HOSTACK Kitchen Island Cart Model 257 User Manual

Brand: HOSTACK | Model: 257

## INTRODUCTION

This manual provides essential information for the safe and effective use of your HOSTACK Kitchen Island Cart Model 257. Please read all instructions carefully before assembly and operation. Keep this manual for future reference.

## SAFETY INFORMATION

- Always keep the casters locked when the unit is not in motion to ensure stability.
- Keep storage spaces clear of sharp objects to prevent injury.
- Do not overload shelves or drawers to maintain stability and prevent damage.
- Keep the product away from direct heat sources to prevent warping or material damage.
- Ensure all components are securely fastened during assembly and periodically check for loose connections.

## PRODUCT OVERVIEW

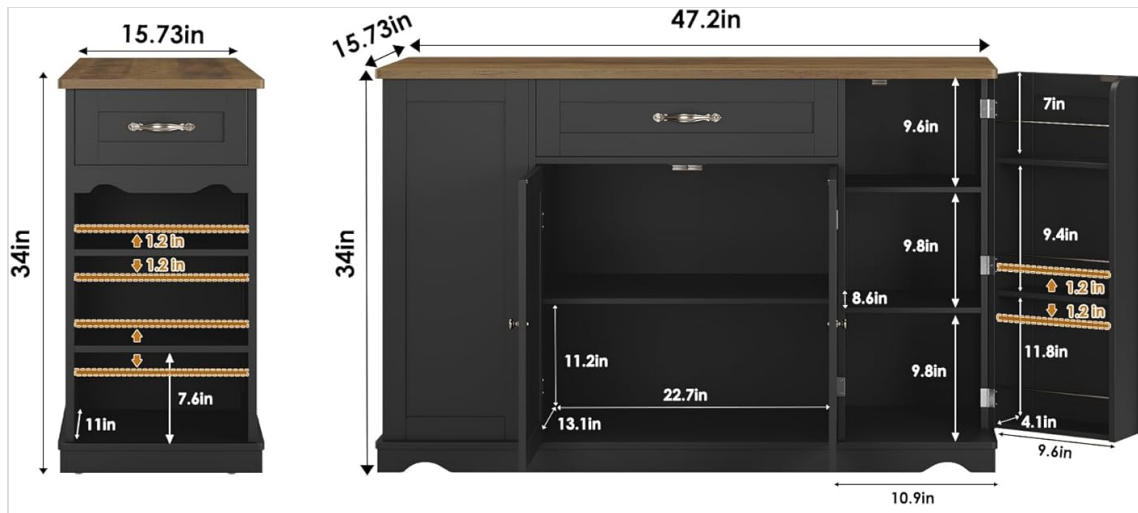
The HOSTACK Kitchen Island Cart Model 257 is designed to provide versatile storage and additional workspace in your kitchen or dining area. It features multiple storage options and mobile functionality.

### Key Features:

- **Spacious Storage:** Includes two drawers of different sizes, a three-door cabinet, and a side storage rack for various kitchen items.
- **Smooth Mobility:** Equipped with five smooth swivel casters, including one central caster for enhanced stability during movement.
- **User-Friendly Design:** Features adjustable shelves within the side open cabinet for customizable storage and a swing-out door storage rack for easy access to spices and beverages.
- **Versatile Functionality:** Can serve as an extra cooking countertop, a buffet sideboard, or a mobile coffee bar.
- **Robust Construction:** Made from high-quality MDF for stability and durability.

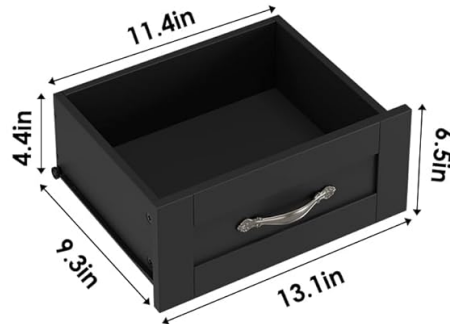
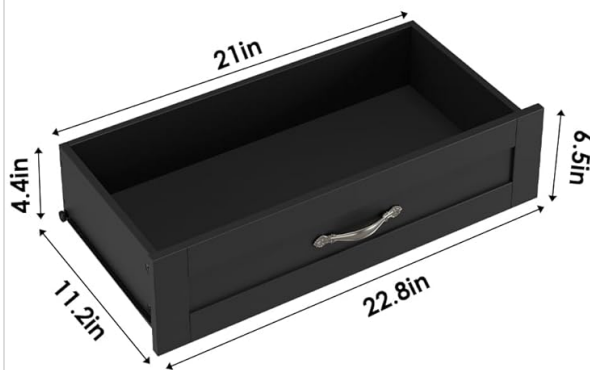


Figure 1: An overall view of the HOSTACK Kitchen Island Cart, showcasing its black finish, rustic brown countertop, and functional design within a kitchen setting.



### Interior Drawer Size

### 3 Adjustable Shelves



**X5**

Figure 2: Detailed diagram illustrating the overall dimensions of the kitchen island cart, including depth, width, and height, along with the interior measurements of the two drawers.



Figure 3: Image displaying the kitchen island cart with its side storage rack open, revealing multiple shelves designed for bottles, jars, and other kitchen essentials.



Figure 4: View of the main cabinet storage area, highlighting the adjustable shelves that allow for customized organization of various kitchen items like plates, cups, and small appliances.

# Spacious Tabletop Two Sized Drawers



-  **Sturdy Structure**
-  **Large Storage Space**
-  **Easy to Assemble**

Figure 5: An aerial perspective of the kitchen island cart, emphasizing the spacious tabletop and the two open drawers, one larger and one smaller, suitable for cutlery and other kitchen tools.

Video 1: This video provides a visual tour of the HOSTACK Kitchen Island, showcasing its various storage compartments, drawers, and overall design, highlighting its functionality in a kitchen environment.

## SETUP

Assembly of the HOSTACK Kitchen Island Cart is required. Please refer to the detailed assembly instructions included in the product packaging. Ensure all parts are present before beginning assembly. A screwdriver and possibly a power drill (set to low torque) may be helpful for faster and more efficient assembly. Follow each step carefully to ensure proper construction and stability.

## OPERATION

### Using Drawers:

The cart features two drawers. The larger drawer is suitable for storing various tableware, while the smaller drawer is ideal for culinary tools like plates and silverware. Gently pull the handles to open and push to close.

### Adjustable Shelves:

The side open cabinet includes adjustable shelves. To adjust, remove the shelf and reposition the shelf pins to your

desired height. Ensure the shelf is level and securely placed on the pins before loading items.

### Mobility and Stability:

The kitchen island is equipped with five swivel casters for easy movement. To move the cart, unlock the casters if they are engaged. Once in the desired position, engage the caster locks to prevent unintended movement and ensure stability during use.

### Side Storage Rack:

The swing-out door on the side provides a convenient storage rack. This is ideal for organizing spices, small bottles, or other frequently accessed items. Open the door gently to access the rack and close it securely when finished.

## MAINTENANCE

---

### Cleaning:

Wipe surfaces with a soft, damp cloth. Avoid using harsh chemicals or abrasive cleaners, as these may damage the finish. For the rustic brown countertop, use a wood-safe cleaner if necessary and dry immediately.

### General Care:

Periodically check all screws and fasteners to ensure they remain tight. Re-tighten if necessary. Inspect casters for smooth operation and clean any debris that may hinder movement. Avoid placing excessively hot items directly on the countertop without protection.

## TROUBLESHOOTING

---

### Stability Issues:

If the cart feels wobbly, ensure all assembly screws are tightened. Verify that the casters are locked when the unit is stationary. Uneven flooring may also affect stability; consider using shims if needed.

### Drawer Malfunction:

If a drawer sticks or does not slide smoothly, check for obstructions in the drawer slides. Ensure the drawer is properly aligned on its tracks. Lightly lubricate slides with a silicone-based spray if friction persists.

### Caster Movement:

If casters do not roll freely, check for hair or debris wrapped around the wheels. Clean as necessary. If casters do not lock, ensure the locking mechanism is fully engaged.

## SPECIFICATIONS

---

Feature	Detail
Brand	HOSTACK
Model Number	257
Product Dimensions (D x W x H)	15.75"D x 47.24"W x 34.06"H
Material	Engineered Wood
Color	Black + Rustic Brown

Number of Drawers	2
Number of Doors	3
Number of Shelves	11 (including adjustable and fixed)
Base Type	Legs with Casters
Assembly Required	Yes

## **WARRANTY AND SUPPORT**

---

For warranty information or technical support, please refer to the documentation included with your purchase or visit the official HOSTACK website. If you encounter any issues not covered in this manual, please contact HOSTACK customer service for assistance.