



[Manuals.plus](#) /

› [Best Choice Products](#) /

› Best Choice Products 36in Large Rolling Kitchen Island Cart (Model SKY11014) Instruction Manual

Best Choice Products SKY11014

Best Choice Products 36in Large Rolling Kitchen Island Cart

Model: SKY11014

INTRODUCTION

This instruction manual provides essential information for the safe assembly, operation, and maintenance of your Best Choice Products 36in Large Rolling Kitchen Island Cart. Please read this manual thoroughly before assembly and use, and retain it for future reference.



Image: The Best Choice Products 36in Large Rolling Kitchen Island Cart in Pistachio Green, showcasing its overall design and features.

SAFETY INFORMATION

For your safety and to prevent damage to the product, observe the following guidelines:

- Ensure all parts are properly secured before use.
- Do not allow children to play on, with, or around the cart.
- Do not exceed the weight capacity of 60 lbs for the overall cart. The pull-out shelf has a weight capacity of 13.2 lbs.
- Use caution when moving the cart on uneven surfaces to prevent tipping.
- Always lock the wheels when the cart is in a stationary position to ensure stability.

PACKAGE CONTENTS

Verify that all components are present before beginning assembly. The package should include:

- All necessary furniture panels and hardware.
- Assembly Guide.

If any parts are missing or damaged, do not proceed with assembly. Contact customer support for assistance.

SETUP AND ASSEMBLY

Assembly of the kitchen island cart is required. Please follow the included Assembly Guide carefully. It is recommended to have a second person assist with assembly to ensure stability and ease of construction.

Important Tips for Assembly:

- Lay out all parts and hardware before starting.
- Identify each component by referring to the parts list in the Assembly Guide.
- Do not overtighten screws during initial assembly; tighten fully once all components are aligned.
- If you encounter difficulty, refer to the detailed diagrams in the Assembly Guide.

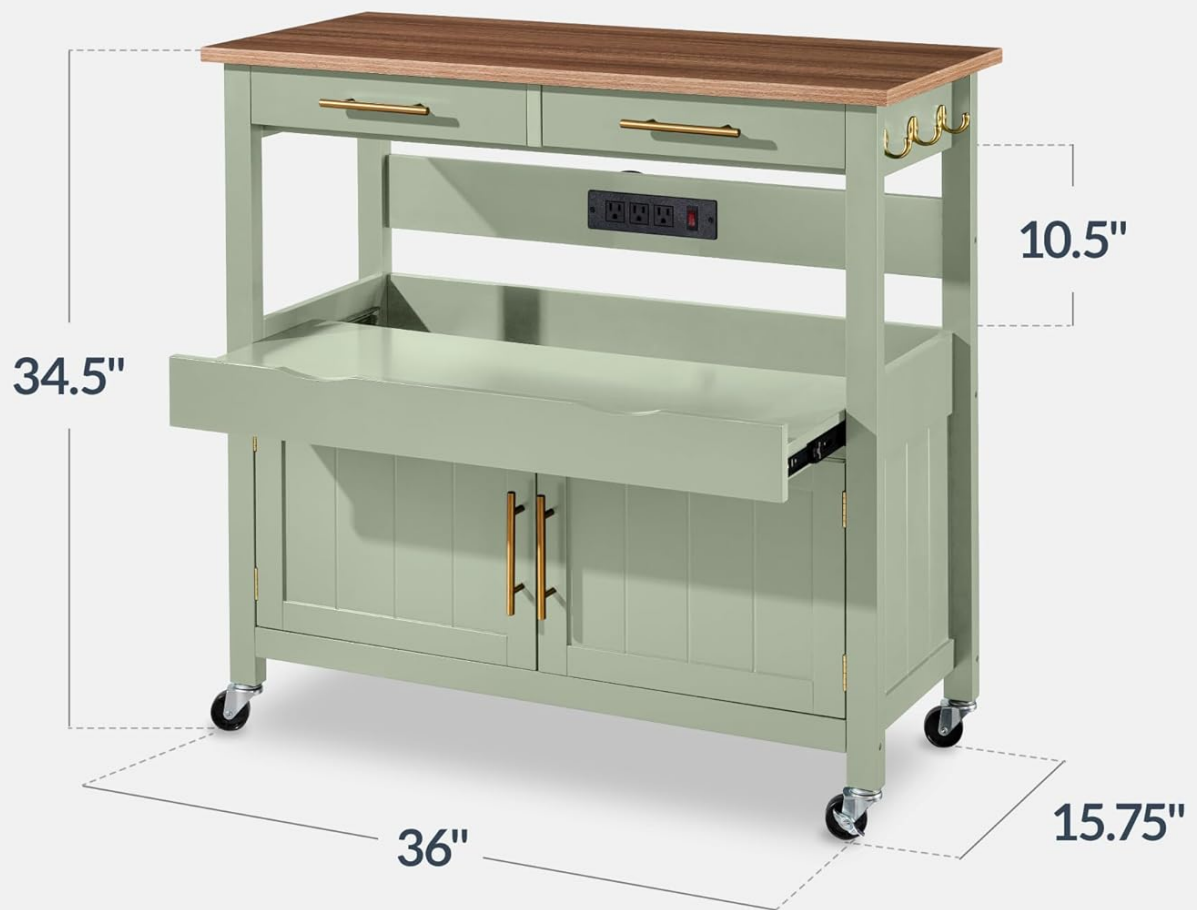

Weight Capacity

Pull-Out Shelf	13.2lbs
Overall	60lbs



LOCKABLE

Image: A detailed diagram illustrating the dimensions (36" L x 15.75" W x 34.5" H) and weight capacities (Pull-Out Shelf: 13.2 lbs, Overall: 60 lbs) of the kitchen island cart.

OPERATING INSTRUCTIONS

Using the Pull-Out Shelf

The smooth-glide pull-out shelf provides convenient access to small appliances or serving dishes. Gently pull the shelf forward to extend it and push it back to retract. Ensure items placed on the shelf do not exceed the 13.2 lbs weight limit.

Pull-Out Shelf

Slide in or out for easy access to ingredients and small appliances



Image: The pull-out shelf extended, demonstrating its use for small appliances like a toaster.

Utilizing Built-In Power Outlets

The cart features three integrated 3-prong power outlets. These outlets are designed to power kitchen appliances or charge devices. To use, plug your appliance into one of the outlets. Ensure the power switch on the outlet strip is in the "ON" position. Always unplug appliances when not in use.

Built-In Outlets



Image: A close-up view of the three built-in 3-prong power outlets with a reset switch, integrated into the cart's design.

Drawers and Cabinet Storage

The two drawers are suitable for storing utensils, linens, or small tools. The two-door cabinet provides larger storage space for pantry items, small appliances, or craft supplies. Open and close drawers and cabinet doors gently to prevent wear and tear.



Image: An open drawer filled with kitchen utensils and the cabinet below, demonstrating the storage capacity.

Lockable Swivel Wheels

The cart is equipped with swivel casters for easy mobility. To move the cart, unlock all wheels. To secure the cart in a stationary position, press down on the locking mechanism on each wheel until it clicks into place. Ensure all wheels are locked before placing heavy items on the cart or using it as a stable workstation.



Image: The kitchen island cart in a kitchen environment, showing its functionality with the pull-out shelf extended and a toaster in use.

Product Overview Video

Your browser does not support the video tag.

Video: An official product video from Best Choice Products Inc, demonstrating the features and versatility of the Large Rolling Kitchen Island Cart, including its mobility, storage, and power outlets.

MAINTENANCE

To maintain the appearance and functionality of your kitchen island cart:

- Wipe surfaces with a soft, damp cloth. Avoid abrasive cleaners or harsh chemicals.
- Periodically check all screws and fasteners to ensure they remain tight. Retighten as necessary.

- Keep the cart dry and away from excessive moisture to prevent damage to the engineered wood and MDF components.

TROUBLESHOOTING

If you encounter issues with your kitchen island cart, consider the following:

Assembly Difficulties

- **Problem:** Parts do not align or screws do not fit.
- **Solution:** Double-check the Assembly Guide to ensure you are using the correct parts for each step and that they are oriented correctly. Loosen previously tightened screws slightly to allow for adjustment, then retighten once aligned.
- **Problem:** Missing or damaged parts.
- **Solution:** Do not attempt to force assembly with incorrect or damaged parts. Contact Best Choice Products customer support for replacement parts.

Stability Issues

- **Problem:** Cart feels wobbly or unstable.
- **Solution:** Ensure all fasteners are securely tightened. Verify that the cart is on a flat, level surface. If moving, ensure all wheels are unlocked; if stationary, ensure all wheels are locked.

Power Outlets Not Working

- **Problem:** Appliances plugged into the cart's outlets do not receive power.
- **Solution:** Check that the power switch on the outlet strip is in the "ON" position. Ensure the cart's main power cord is securely plugged into a functional wall outlet. If the outlets have a reset button, press it.

SPECIFICATIONS

Feature	Detail
Model Number	SKY11014
Product Dimensions (L x W x H)	36" x 15.75" x 34.5"
Item Weight	70 Pounds
Maximum Weight Recommendation	60 lbs (Overall), 13.2 lbs (Pull-Out Shelf)
Material	Engineered Wood, PB, MDF (Medium-Density Fiberboard)
Color	Pistachio Green
Number of Shelves	2 (including pull-out)
Included Components	Assembly Guide
Assembly Required	Yes

WARRANTY INFORMATION

Best Choice Products offers a 60-day warranty. All returns must be shipped back to a Best Choice Products return center

at the customer's expense within 60 days of delivery. However, a pre-paid return shipping label will be provided via email if the return is a result of an error by Best Choice Products. The company reserves the discretion to decide if an item may be returned to a Best Choice Products return center. Unauthorized returns may not be accepted.

Once your claim is processed and approved, please allow 5-7 business days for the request to be completed. If a replacement unit or replacement parts are requested, the fulfillment time-frame is based on product availability.

CUSTOMER SUPPORT

For any questions, missing parts, or warranty claims, please contact Best Choice Products customer support. Refer to the contact information provided in your original purchase documentation or visit the official Best Choice Products website for assistance.

Online Support: [Visit the Best Choice Products Store on Amazon](#)