

Ejoyous Ejoyousw67g8n0gxz

Ejoyous DC 12V Countdown Timing Relay Module User Manual

Model: Ejoyousw67g8n0gxz

1. INTRODUCTION

This manual provides detailed instructions for the installation, operation, and maintenance of your Ejoyous DC 12V Countdown Timing Relay Module. This module is designed for precise time delay control, offering stable and reliable performance for various applications. Please read this manual thoroughly before use to ensure proper functionality and safety.

2. SAFETY INFORMATION

- Ensure the power supply is DC 12V. Connecting to an incorrect voltage may damage the module.
- Always disconnect power before making any wiring connections or adjustments.
- Observe proper polarity when connecting the DC 12V power supply (positive to +, negative to -).
- The relay contacts are rated for AC 0-250V 10A or DC 0-30V 10A. Do not exceed these ratings.
- This module is an electronic component; handle with care to avoid electrostatic discharge.
- Keep the module away from moisture, extreme temperatures, and corrosive environments.

3. PRODUCT FEATURES

- **Versatile Timing Range:** Adjustable delay time from 1 to 99 seconds or 1 to 99 minutes.
- **Clear LED Display:** Shows the remaining delay time for easy monitoring.
- **Accurate Timing Control:** Delivers high precision and stable performance.
- **Intelligent Control:** Connects when triggered, disconnects after delay. Immediate disconnect if re-

triggered during delay.

- **Compact Design:** Measures 70mm x 40mm x 18mm, suitable for space-constrained installations.
- **Reverse Protection:** Integrated circuit for protection against reverse polarity connection.

4. SPECIFICATIONS

Parameter	Value
Operating Voltage	DC 12V
Delay Time Range	1-99 seconds / 1-99 minutes (selectable)
Relay Load Capacity	AC 0-250V 10A / DC 0-30V 10A
Dimensions	70 x 40 x 18mm (2.75 x 1.57 x 0.7 inches)
Display	LED Digital Display

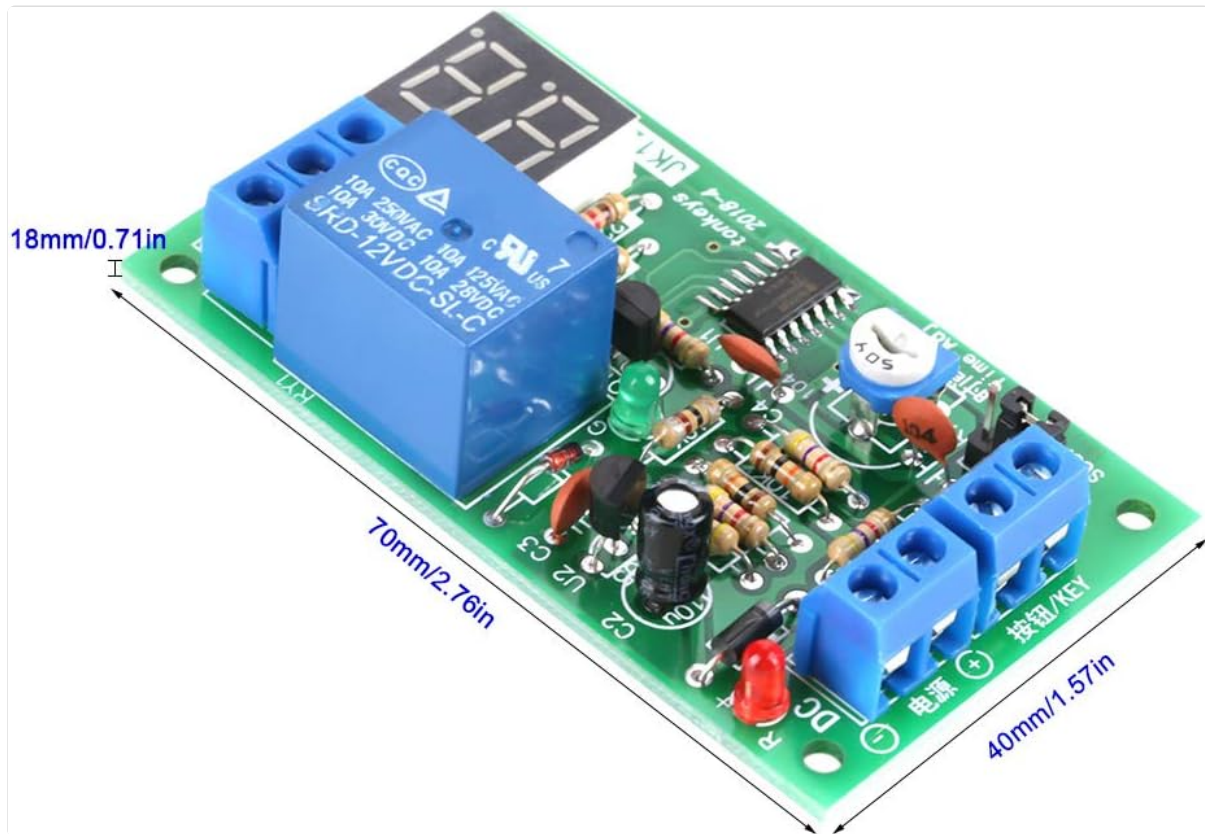

Dimensions of the Ejoyous Timer Relay Module, showing its compact size of 70mm x 40mm x 18mm.

5. COMPONENT IDENTIFICATION

Refer to the diagram below to identify the key components of the timer relay module.

Trigger delay off countdown module

DC 12V
1~99S
1~99min

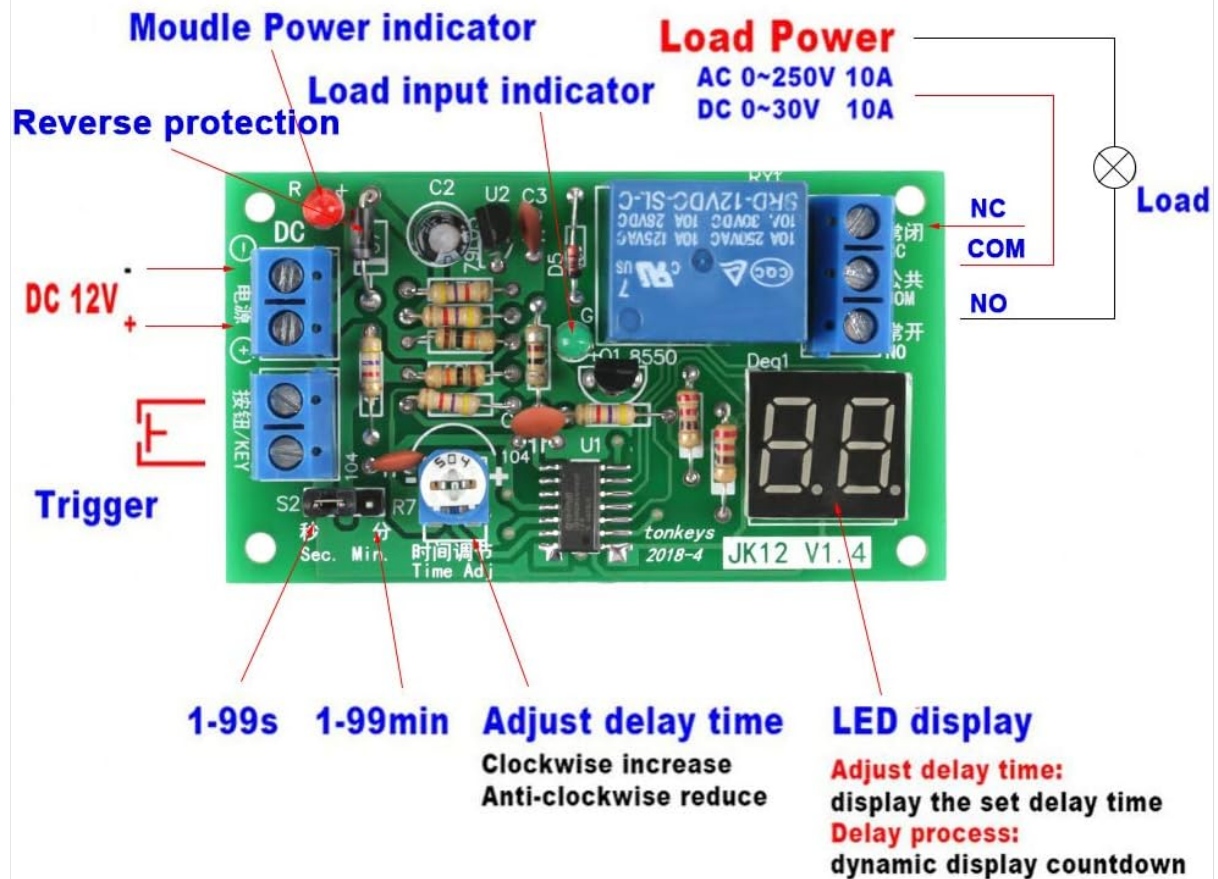

Detailed diagram of the Ejoyous Timer Relay Module, highlighting key components such as power input, trigger input, load connections, LED display, time adjustment potentiometer, and time unit jumper.

- **DC 12V Power Input:** Terminals for connecting the 12V DC power supply.
- **Trigger Input:** Terminals for connecting the trigger signal.
- **Load Power (Relay Output):**
 - **NC (Normally Closed):** Connected to COM when the relay is inactive.
 - **COM (Common):** Common terminal for the relay switch.
 - **NO (Normally Open):** Connected to COM when the relay is active (triggered).
- **LED Display:** Shows the set delay time and counts down during operation.
- **Time Adjustment Potentiometer (R7):** Used to set the delay time value. Clockwise increases time, counter-clockwise reduces time.
- **Time Unit Jumper (S2):** Selects between seconds (Sec.) and minutes (Min.) for the delay time.
- **Module Power Indicator:** LED indicating the module is powered.
- **Load Input Indicator:** LED indicating the relay is active.

6. SETUP AND WIRING

Follow these steps to correctly set up and wire the timer relay module.

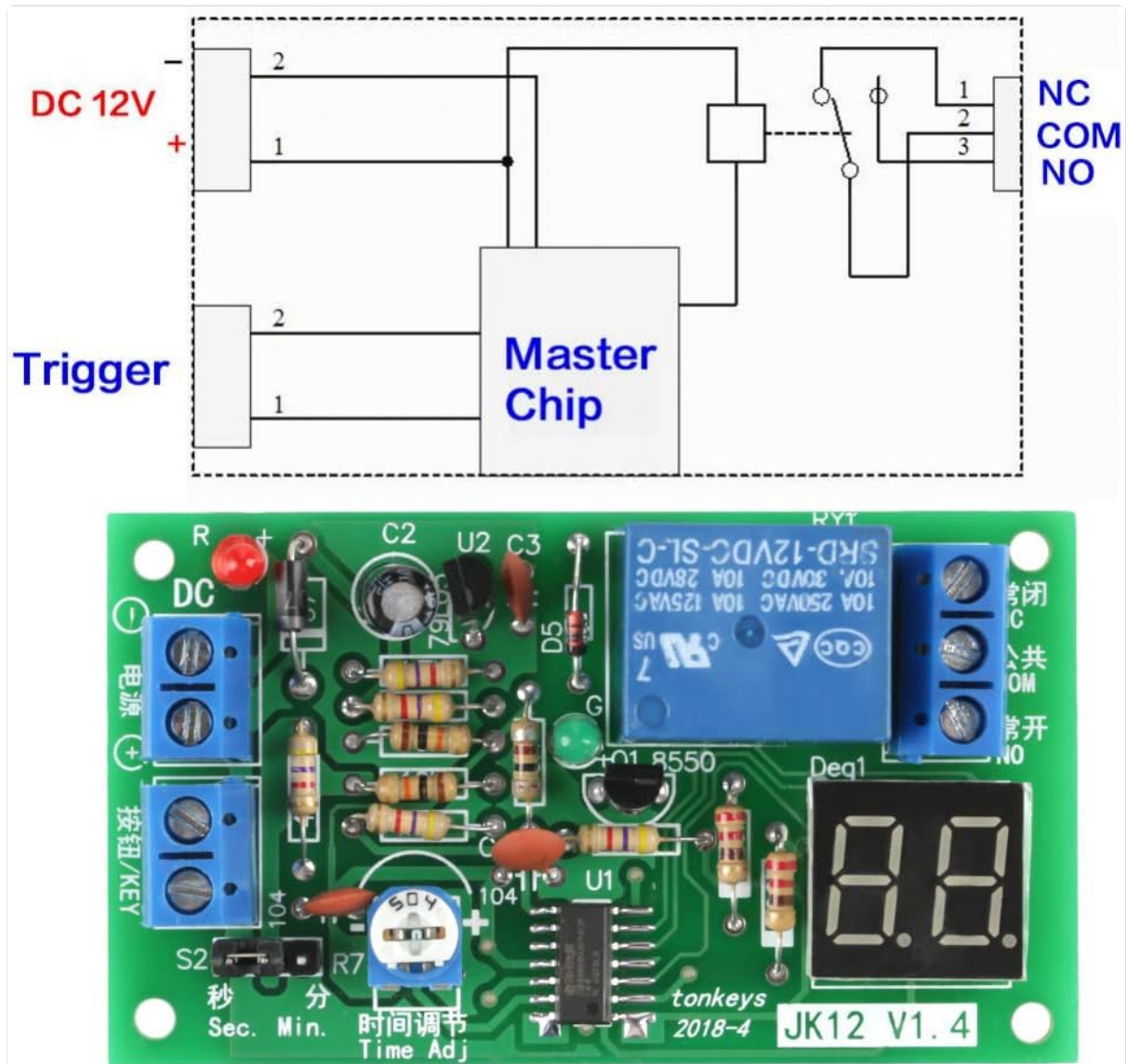

Wiring diagram for the Ejoyous Timer Relay Module, illustrating connections for DC 12V power, trigger input, and the load via the relay's Normally Open (NO), Common (COM), and Normally Closed (NC) terminals.

6.1 Power Connection

1. Connect your DC 12V power supply to the terminals labeled 'DC 12V' or '+' and '-'. Ensure correct polarity.

6.2 Load Connection

1. Identify the load you wish to control (e.g., a light, motor, or other device).
 2. Connect one side of your load to the **COM** (Common) terminal of the relay.
 3. Connect the other side of your load to either the **NO** (Normally Open) or **NC** (Normally Closed) terminal, depending on your desired operation:
 - Use **NO** if you want the load to turn ON when the relay is active (during the delay countdown).
 - Use **NC** if you want the load to turn OFF when the relay is active (during the delay countdown).
- Complete the circuit for your load by connecting the remaining terminal of the load to its power source.

6.3 Trigger Connection

1. Connect your trigger source (e.g., a switch, sensor output) to the terminals labeled 'Trigger' or 'KEY'.
2. A momentary connection (short pulse) between these two terminals will initiate the countdown.
3. If you require the module to start immediately upon power-on without an external trigger, connect the two trigger terminals together permanently.

7. OPERATING INSTRUCTIONS

7.1 Setting the Delay Time Unit

1. Locate the jumper labeled 'S2' (Sec./Min.).
2. Move the jumper to the 'Sec.' position for delay times in seconds (1-99 seconds).
3. Move the jumper to the 'Min.' position for delay times in minutes (1-99 minutes).

7.2 Adjusting the Delay Time Value

1. Locate the potentiometer labeled 'R7' or 'Time Adj'.
2. Use a small screwdriver to turn the potentiometer.
3. Turning clockwise increases the delay time.
4. Turning counter-clockwise decreases the delay time.
5. The LED display will show the set delay time value as you adjust it.

7.3 Initiating the Countdown

1. Once power is applied and the time is set, briefly connect the 'Trigger' terminals.
2. The LED display will show the set time and begin counting down.
3. During the countdown, the relay will be active (COM connected to NO, NC disconnected).
4. When the countdown reaches zero, the relay will deactivate (COM connected to NC, NO disconnected).
5. If the trigger is activated again during an active countdown, the relay will immediately disconnect, and the countdown will reset and restart upon the next trigger.

8. MAINTENANCE

- Keep the module clean and free from dust. Use a soft, dry cloth for cleaning.
- Avoid exposing the module to liquids or excessive humidity.
- Store the module in a dry, cool environment when not in use.
- Regularly check wiring connections to ensure they are secure.

9. TROUBLESHOOTING

- **Module does not power on:** Check DC 12V power supply connections and ensure correct polarity. Verify the power source is active.

- **LED display is off:** Confirm power connection. If power is present, the module may be faulty.
- **Module does not trigger:** Ensure the trigger terminals are correctly connected and receiving a signal. If immediate operation is desired, ensure the trigger terminals are permanently shorted.
- **Incorrect delay time:** Verify the 'Sec./Min.' jumper setting. Adjust the 'Time Adj' potentiometer carefully.
- **Relay does not switch:** Check load wiring and ensure the load's power source is connected. Verify the load current does not exceed the relay's maximum rating.

10. WARRANTY AND SUPPORT

Ejoyous products are designed for reliability and performance. For any technical support or warranty inquiries, please refer to the contact information provided with your purchase or visit the official Ejoyous website. Please retain your proof of purchase for warranty claims.