

Christopher Knight Home 331395

Christopher Knight Home Twin to King Convertible Daybed Instruction Manual

Model: 331395

1. PRODUCT OVERVIEW

This manual provides instructions for the Christopher Knight Home Twin Size Daybed Frame with Pop Up Trundle, Model 331395. This versatile furniture piece functions as both a sofa and a bed, featuring a pop-up trundle that converts a twin-sized sleeping area into a king-sized one. It is designed for use in living rooms, guest rooms, or studios, offering a blend of functionality and contemporary style.

Key Features:

- **Adjustable Pop-Up Trundle:** Smooth mechanism allows conversion from twin to king size.
- **Multi-Functional Design:** Serves as a sofa during the day and a bed at night.
- **Luxurious Velvet Upholstery:** Soft velvet fabric with padded armrests for comfort.
- **Sturdy Construction:** Reinforced metal frame and durable wooden slats.
- **Space-Saving Solution:** Ideal for compact living spaces.



Image 1.1: The daybed configured as a sofa, showcasing its upholstered design and armrests.



Image 1.2: A diagram highlighting the daybed's space-saving, extended, pop-up, and multi-functional capabilities.

2. SAFETY INFORMATION

Please read and follow all safety instructions carefully to ensure safe use of this product.

- Always follow the assembly instructions provided.
- Do not exceed the weight capacity of 330 lbs for the twin size and 660 lbs total when extended.
- Keep the area around the bed clear of obstacles to prevent tripping or entrapment.
- This product is not intended for children under 3 years old.

3. SETUP INSTRUCTIONS

Assembly of the daybed is required. It is recommended that two people assist with the assembly process. All necessary hardware and clear instructions are included in the packaging.

General Assembly Steps:

1. **Unpack Components:** Carefully remove all parts from the packaging and lay them out on a clean, soft surface to prevent scratches. Verify all components and hardware are present against the included parts list.
2. **Assemble Main Frame:** Follow the step-by-step diagrams in the provided instruction booklet to connect the main frame components, including the side panels and backrest.
3. **Install Slats:** Securely attach the wooden slats to the main bed frame. Ensure they are evenly spaced and firmly fastened to provide adequate mattress support.
4. **Assemble Trundle Unit:** Construct the pop-up trundle frame according to the instructions. This typically involves attaching wheels and the lifting mechanism.
5. **Integrate Trundle:** Slide the assembled trundle unit under the main daybed frame.
6. **Final Checks:** Ensure all bolts and screws are tightened. Do not overtighten. Confirm the daybed and trundle operate smoothly.



Image 3.1: The internal structure of the daybed, showing the wooden slats that support the mattress.

4. OPERATING INSTRUCTIONS

The Christopher Knight Home Daybed is designed for easy conversion between a twin-sized sofa/bed and a king-sized bed.

Converting from Twin to King:

1. **Pull Out Trundle:** Locate the handle or edge of the trundle unit beneath the main daybed. Gently pull the trundle straight out until it is fully extended and clear of the main frame.
2. **Engage Pop-Up Mechanism:** Once the trundle is fully pulled out, lift the trundle frame upwards. The pop-up mechanism will engage, raising the trundle to the same height as the main daybed.
3. **Align Trundle:** Carefully push the raised trundle alongside the main daybed, aligning the two frames to create a continuous king-sized sleeping surface.



Image 4.1: The trundle unit being smoothly pulled out from beneath the main daybed frame.



Image 4.2: The trundle unit in its popped-up position, ready to be aligned with the main daybed to form a larger sleeping area.



Image 4.3: The daybed fully extended, demonstrating the king-sized configuration with the pop-up trundle.

Converting from King to Twin:

1. **Separate Trundle:** Gently pull the trundle unit away from the main daybed.
2. **Lower Trundle:** Disengage the pop-up mechanism and carefully lower the trundle frame back to its stored height.
3. **Slide Under Daybed:** Push the lowered trundle unit back under the main daybed until it is fully stored.

5. MAINTENANCE

Proper care and maintenance will extend the life and appearance of your daybed.

Cleaning and Care:

- **Upholstery:** For general cleaning, vacuum the velvet upholstery regularly using a soft brush attachment to remove dust and debris. For spills, blot immediately with a clean, dry cloth. Do not rub. For stubborn stains, consult a professional upholstery cleaner. Avoid using harsh chemicals or abrasive cleaners.
- **Frame:** Wipe the metal frame with a soft, damp cloth. Avoid using harsh chemicals.

- **Hardware:** Periodically check all bolts and screws to ensure they remain tight. Retighten if necessary, but do not overtighten.
- **Sunlight Exposure:** Avoid prolonged exposure to direct sunlight to prevent fading of the upholstery fabric.

6. TROUBLESHOOTING

If you encounter any issues with your daybed, refer to the following common problems and solutions.

Common Issues:

- **Difficulty Pulling Out/Pushing In Trundle:**
Solution: Check for any obstructions beneath the daybed or along the trundle's path. Ensure the wheels are clean and free of debris. Verify that the trundle mechanism is properly aligned.
- **Trundle Not Popping Up/Down Smoothly:**
Solution: Inspect the pop-up mechanism for any bent parts or obstructions. Ensure all connecting hardware is securely fastened. Apply a silicone-based lubricant to moving parts if necessary, avoiding contact with upholstery.
- **Squeaking Noises:**
Solution: Tighten all assembly bolts and screws. Ensure all wooden slats are properly seated and secured to the frame. If the noise persists, disassemble and reassemble the affected section, ensuring all parts are correctly aligned.
- **Instability/Wobbling:**
Solution: Verify that the daybed is placed on a flat, level surface. Check all connections and tighten any loose hardware. Ensure all legs are making firm contact with the floor.

7. SPECIFICATIONS

Detailed specifications for the Christopher Knight Home Twin to King Convertible Daybed, Model 331395.

Feature	Detail
Overall Type	Twin to King Convertible Daybed
Model Number	331395
Material	Velvet, Metal, Wood
Color	Gray
Weight Capacity (Twin)	330 lbs
Weight Capacity (Total, King)	660 lbs
Recommended Trundle Mattress Height	≤ 5.5 inches
Assembly Required	Yes (2 people suggested)
Product Dimensions (L x W x H)	210.06 cm x 205.99 cm x 71.88 cm (82.7 in x 81.1 in x 28.3 in)

Product Weight

53.75 kg (118.5 lbs)

Size: inch

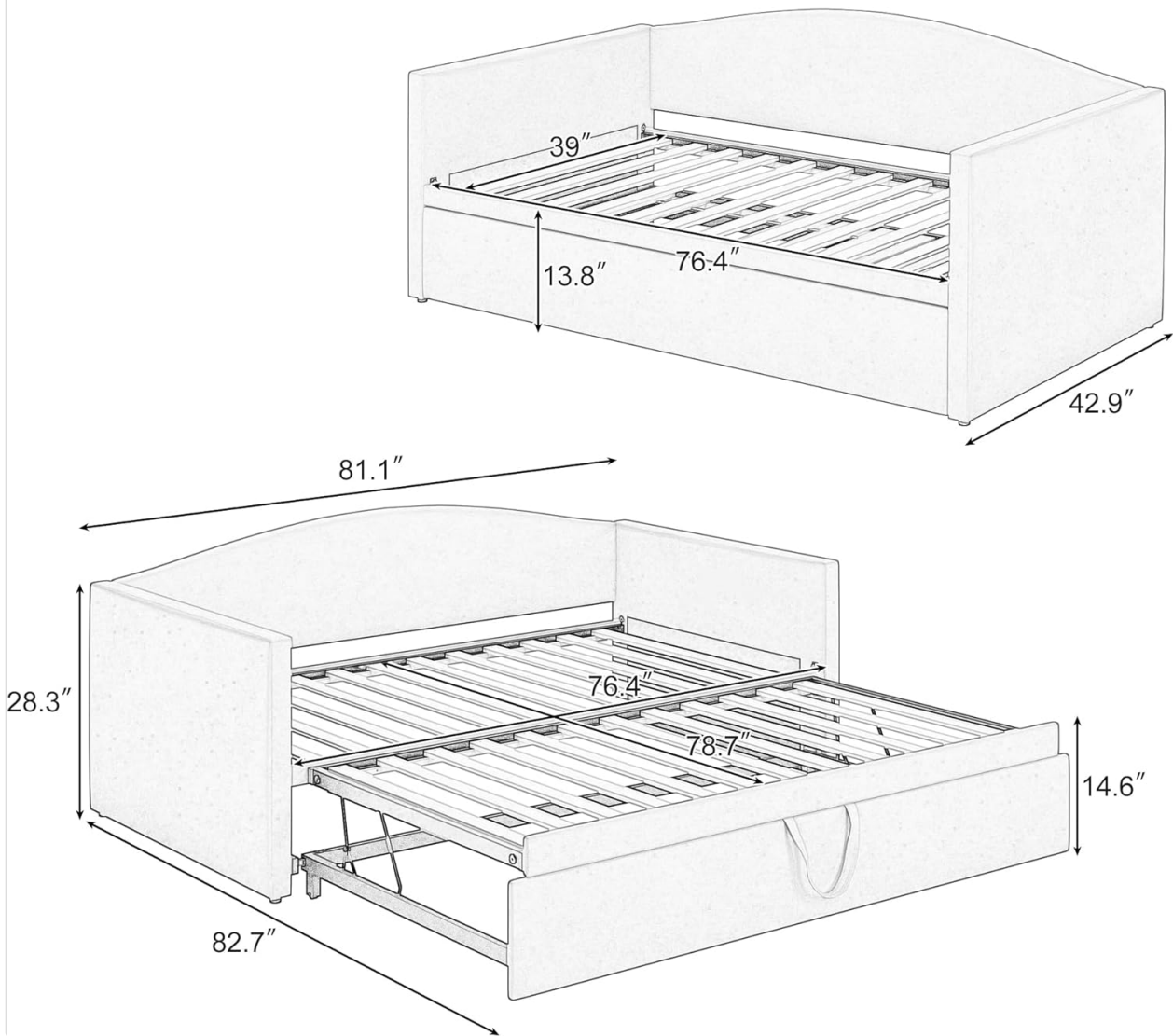

Image 7.1: Dimensional drawing of the daybed, showing measurements for both the compact twin and extended king configurations.

8. WARRANTY AND SUPPORT

For customer assistance or inquiries, please refer to the contact information below.

Customer Support:

- Our team is available 24/7 to assist you with any product-related questions or concerns.
- **Manufacturer Contact:** amazonvendorfeedback@gdfstudio.zendesk.com

Specific warranty details are not provided in this manual. Please contact customer support for information regarding product warranty.

