

Manuals.plus /

› LOVEWE /

› LOVEWE Lovewe-ms42 Manual Frozen Meat Slicer User Manual

LOVEWE Lovewe-ms42

LOVEWE Lovewe-ms42 Manual Frozen Meat Slicer User Manual

Model: Lovewe-ms42

INTRODUCTION

Thank you for choosing the LOVEWE Lovewe-ms42 Manual Frozen Meat Slicer. This manual provides essential information for the safe and efficient operation, maintenance, and care of your new slicer. Please read these instructions thoroughly before first use and retain them for future reference.

This manual slicer is designed for precise and uniform slicing of frozen meats such as beef and lamb, as well as various firm vegetables like lotus root, carrots, and potatoes. Its adjustable thickness feature allows for cuts from 0.3mm to 8mm, catering to diverse culinary needs.

SAFETY INSTRUCTIONS

- Always handle the blade with extreme caution. The blade is very sharp and can cause serious injury.
- Keep fingers and hands away from the blade during operation and cleaning.
- Ensure the slicer is placed on a stable, flat, and dry surface before use. The suction cup feet must be securely engaged.
- Keep the slicer out of reach of children.
- Do not attempt to slice bones or excessively hard items, as this can damage the blade and the slicer.
- Always use the food press handle to hold the food item securely while slicing.
- Clean the slicer immediately after each use to prevent food residue buildup.

PACKAGE CONTENTS

Please check the package to ensure all components are present:

- LOVEWE Lovewe-ms42 Manual Frozen Meat Slicer Unit
- Food Press Handle
- Adjustable Thickness Knob
- User Manual (this document)

SETUP

Assembly

The LOVEWE Lovewe-ms42 slicer typically comes pre-assembled. If any components are detached, ensure the blade arm is securely attached to the base and the food press handle slides smoothly along its track.

Placement

1. Choose a clean, dry, and flat countertop surface for operation.
2. Place the slicer on the chosen surface.
3. Press down firmly on the slicer's base to engage the suction cup feet. Ensure all four suction cups are securely attached to the countertop to prevent movement during slicing.

Multi-functional Slicing



Image: The slicer base with its four suction cup feet securely holding it to a surface, ensuring stability during use.

Structural Features

The slicer features an M-type support for strong load bearing and stable support, along with an X-shaped floor reinforcement on the tabletop to ensure stability and prevent collapse during operation. The two-bearing design contributes to smoother and more efficient slicing.

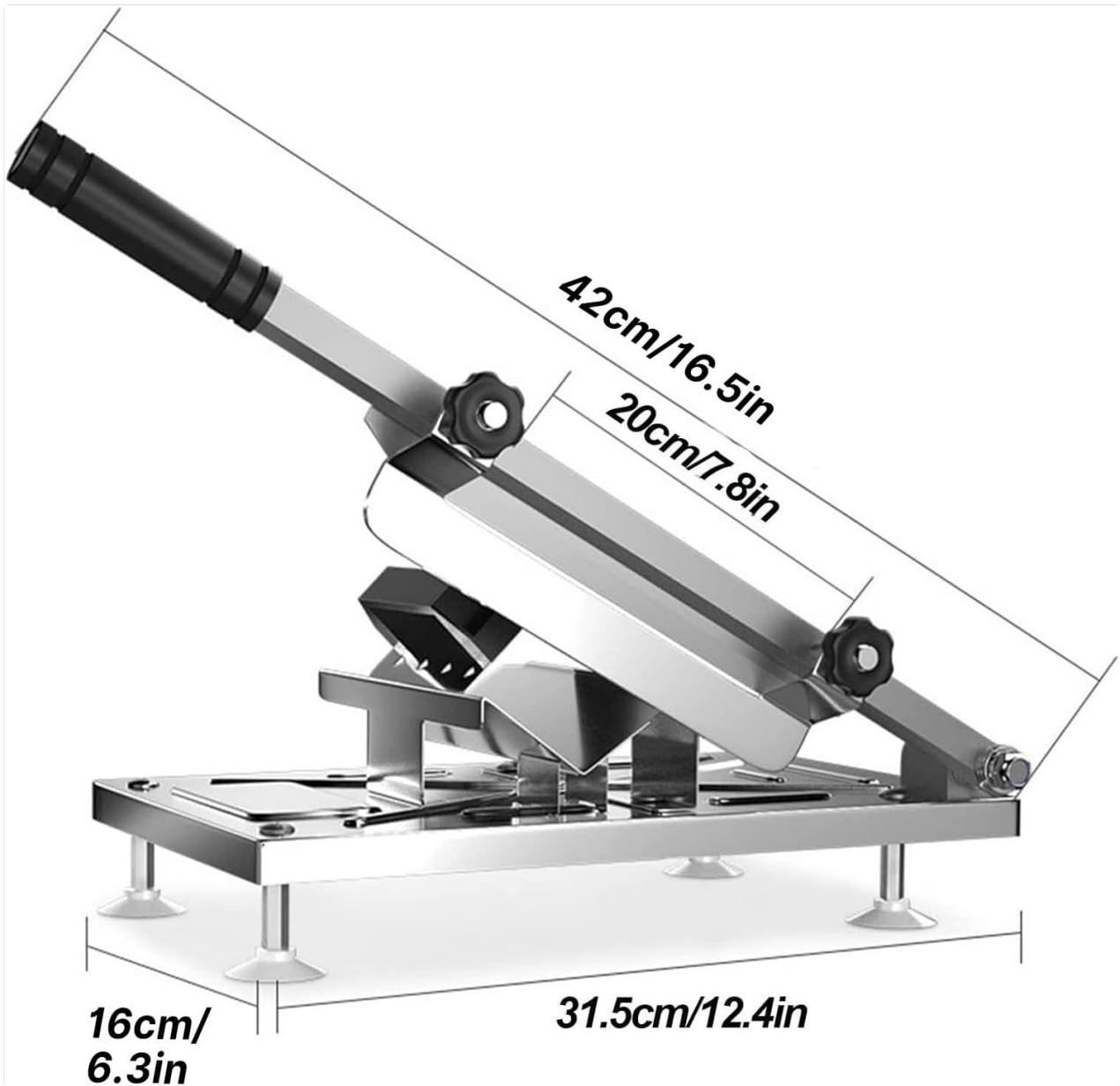

Image: Detail showing the M-type support structure for stability and the high resilience mechanism designed to feed meat easily.

Adjustable Thickness

Adjustable from 0.3mm to 8mm

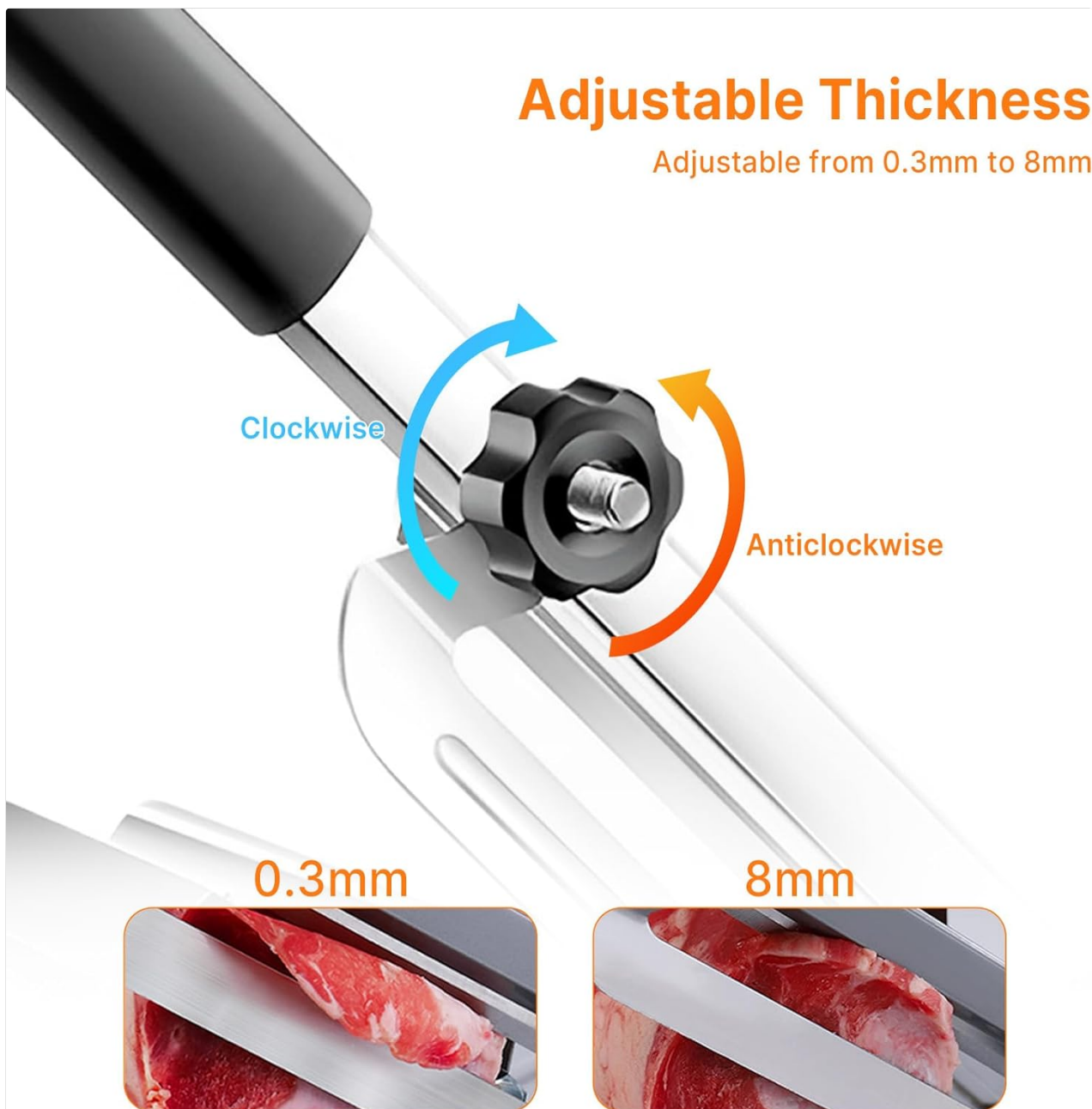

Image: Detail illustrating the X-shaped reinforcement on the slicer's base for enhanced stability and the two-bearing design for effortless slicing.

OPERATING INSTRUCTIONS

Preparing Food for Slicing

For optimal results when slicing meat, ensure the meat is thoroughly frozen. A partially thawed or soft piece of meat will be difficult to slice uniformly. For vegetables, ensure they are firm and clean.

Adjusting Slice Thickness

The slicer allows for adjustable slice thickness from 0.3mm to 8mm. To adjust:

- Locate the black adjustable knob on the side of the blade arm.
- Turn the knob **clockwise** for thinner slices (down to 0.3mm).
- Turn the knob **anticlockwise** for thicker slices (up to 8mm).

- Test the thickness on a small piece of food before slicing the main portion.



Image: A visual guide demonstrating how to use the adjustable knob to set slice thickness, ranging from 0.3mm to 8mm.

Slicing Procedure

1. Ensure the slicer is securely placed on the countertop.
2. Place the frozen meat or firm vegetable onto the food carriage.
3. Use the food press handle to firmly secure the food item against the blade guide.
4. Hold the main handle and push the blade arm forward and backward in a smooth, consistent motion.
5. The sliced food will fall onto the base or a plate placed beneath the blade.
6. Continue slicing until the desired amount is achieved.



Image: A user operating the manual meat slicer, demonstrating the slicing motion with a large cut of frozen meat. Plates of thinly sliced meat rolls and cucumbers are visible, showcasing the slicer's output.

Versatile Slicing Applications

Beyond frozen meats, this slicer is suitable for a variety of firm foods:

- **Frozen Meat:** Ideal for lamb rolls, beef rolls, and other deli-style meats for hot pot or sandwiches.
- **Vegetables:** Perfect for slicing lotus root, carrots, potatoes, and other firm root vegetables.
- **Other Foods:** Can also be used for slicing certain firm fruits, dried goods like ginseng, or even homemade nougat.

M-type support

Strong load bearing,
more stable support



High Resilience

High rebound to feed
meat more easily

Image: A graphic highlighting the slicer's versatility, showing examples of frozen meat, lotus root, carrots, and potatoes as suitable items for slicing.



Image: The slicer displayed with a variety of prepared foods, including thinly sliced ginseng, beef jerky, nougat pieces, and neatly rolled frozen meat slices, demonstrating its wide range of applications.

MAINTENANCE AND CLEANING

Cleaning After Use

Proper cleaning is crucial for hygiene and extending the life of your slicer.

- Immediately after each use, carefully remove any food residue from the blade and other surfaces.
- Hand wash all components with warm, soapy water. Use a brush for hard-to-reach areas.
- Rinse thoroughly with clean water.
- Dry all parts completely with a soft cloth to prevent water spots and rust, especially on the stainless steel blade.
- Do not use abrasive cleaners or scouring pads, as these can scratch the surface.
- The slicer is not dishwasher safe.

Storage

Store the slicer in a clean, dry place, away from direct sunlight and moisture. Ensure the blade is protected to prevent accidental injury and damage.

TROUBLESHOOTING

- **Slicer is unstable:** Ensure all four suction cup feet are clean and firmly pressed onto a smooth, dry countertop surface.
- **Difficulty slicing:** Check if the food item is sufficiently frozen (for meat) or firm (for vegetables). A partially thawed item can be difficult to slice cleanly. Ensure the blade is clean and free of residue.
- **Uneven slices:** Verify that the food item is held firmly against the blade guide with the food press handle. Ensure the thickness adjustment knob is set correctly and not shifting during operation.
- **Blade feels dull:** Over time, blades may require sharpening. If the blade performance significantly degrades, consider professional sharpening or replacement if available.

SPECIFICATIONS

| Feature | Specification |
|--------------------------------|--|
| Brand | LOVEWE |
| Model Number | Lovewe-ms42 |
| Product Dimensions (L x W x H) | 12.4"L x 6.3"W x 2.56"H (31.5cm L x 16cm W x 6.5cm H) |
| Material | Stainless Steel, Plastic |
| Color | Silver |
| Adjustable Thickness | 0.3mm - 8mm |
| Operation Mode | Manual |
| Blade Material | Stainless Steel |
| Blade Length | 7.8 Inches (20cm) |
| Item Weight | 3.64 Pounds (1.65 kg) |
| Special Features | Adjustable Thickness, Multi-functional Slicing, Non-electric, Suction Cup Feet |

X-shaped Floor Reinforcement

Tabletop is stable and does not collapse



Two Bearings Design

Slicing saves time and effort

Image: A diagram illustrating the key dimensions of the slicer, including its length (42cm/16.5in), blade length (20cm/7.8in), and base dimensions (31.5cm/12.4in L x 16cm/6.3in W).

WARRANTY AND SUPPORT

For information regarding warranty coverage, product support, or replacement parts, please refer to the retailer where the product was purchased or contact LOVEWE customer service directly. Contact details are typically provided with your purchase documentation or on the official LOVEWE website.