

Manuals.plus /

› ZIPRO /

› ZIPRO Adjustable Dumbbell 24/36 kg Instruction Manual

ZIPRO B0D1VTNJPC

ZIPRO Adjustable Dumbbell 24/36 kg Instruction Manual

Brand: ZIPRO

Model: B0D1VTNJPC

1. INTRODUCTION

Thank you for choosing the ZIPRO Adjustable Dumbbell. This manual provides essential information for the safe and effective use of your new fitness equipment. The adjustable dumbbell offers a versatile weight range from 2.2 kg to 36 kg, allowing for a wide variety of exercises and progressive training in a compact design. Please read this manual thoroughly before initial use and keep it for future reference.

2. SAFETY INFORMATION

- Consult a physician before starting any new exercise program.
- Always inspect the dumbbell for any damage or loose parts before each use. Do not use if damaged.
- Ensure the weight selection mechanism is securely locked before lifting the dumbbell from its base. A distinct "click" sound confirms locking.
- Use the dumbbell on a flat, stable, and non-slip surface.
- Keep children and pets away from the equipment during use.
- Do not drop the dumbbell, as this can damage the mechanism and void the warranty.
- Do not attempt to disassemble the dumbbell beyond what is described in this manual.
- Wear appropriate athletic footwear and clothing during exercise.
- Stay hydrated and listen to your body. Stop exercising if you feel pain, dizziness, or nausea.

3. PRODUCT COMPONENTS

The ZIPRO Adjustable Dumbbell consists of the following main components:

- **Dumbbell Handle:** The central bar with a knurled grip.
- **Weight Plates:** Individual plates that can be added or removed.

- **Weight Selection Dial:** Mechanism on each end of the handle to select desired weight.
- **Safety Locking System:** Ensures selected plates are securely attached.
- **Storage Base:** Holds the dumbbell and unselected weight plates when not in use.



Figure 3.1: The ZIPRO Adjustable Dumbbell on its storage base.



Figure 3.2: Components of the adjustable dumbbell, including the handle, plates, and base.

4. SETUP

The ZIPRO Adjustable Dumbbell comes pre-assembled. Follow these steps to prepare it for use:

1. **Unpacking:** Carefully remove the dumbbell and its storage base from the packaging.
2. **Placement:** Place the storage base on a flat, stable, and level surface where you intend to exercise. Ensure there is enough clear space around the dumbbell for safe movement.
3. **Initial Inspection:** Before first use, visually inspect all parts for any signs of damage from shipping. Ensure all weight plates are properly seated in the base and the handle is correctly positioned.



Figure 4.1: Dumbbell correctly placed in its storage base.

5. OPERATING INSTRUCTIONS: WEIGHT ADJUSTMENT

The ZIPRO Adjustable Dumbbell allows for quick and easy weight changes. Always adjust the weight while the dumbbell is securely placed in its storage base.

1. **Place Dumbbell in Base:** Ensure the dumbbell is fully seated in its storage base. The handle should be centered, and all weight plates should be aligned.
2. **Select Desired Weight:** Locate the weight selection dial on each end of the dumbbell handle. Rotate both dials simultaneously to your desired weight setting. The available weight increments are clearly marked.

3. **Confirm Locking:** As you rotate the dials, you will hear a distinct "click" sound, indicating that the internal locking mechanism is engaging or disengaging the weight plates. Ensure both dials are set to the same weight and are fully locked into position.
4. **Lift Dumbbell:** Once the desired weight is selected and locked, firmly grasp the handle and lift the dumbbell straight up from the base. Only the selected weight plates will lift with the handle, leaving the unselected plates in the base.
5. **Return Dumbbell:** After your exercise, carefully place the dumbbell back into its storage base, ensuring it is fully seated before attempting to change the weight again.

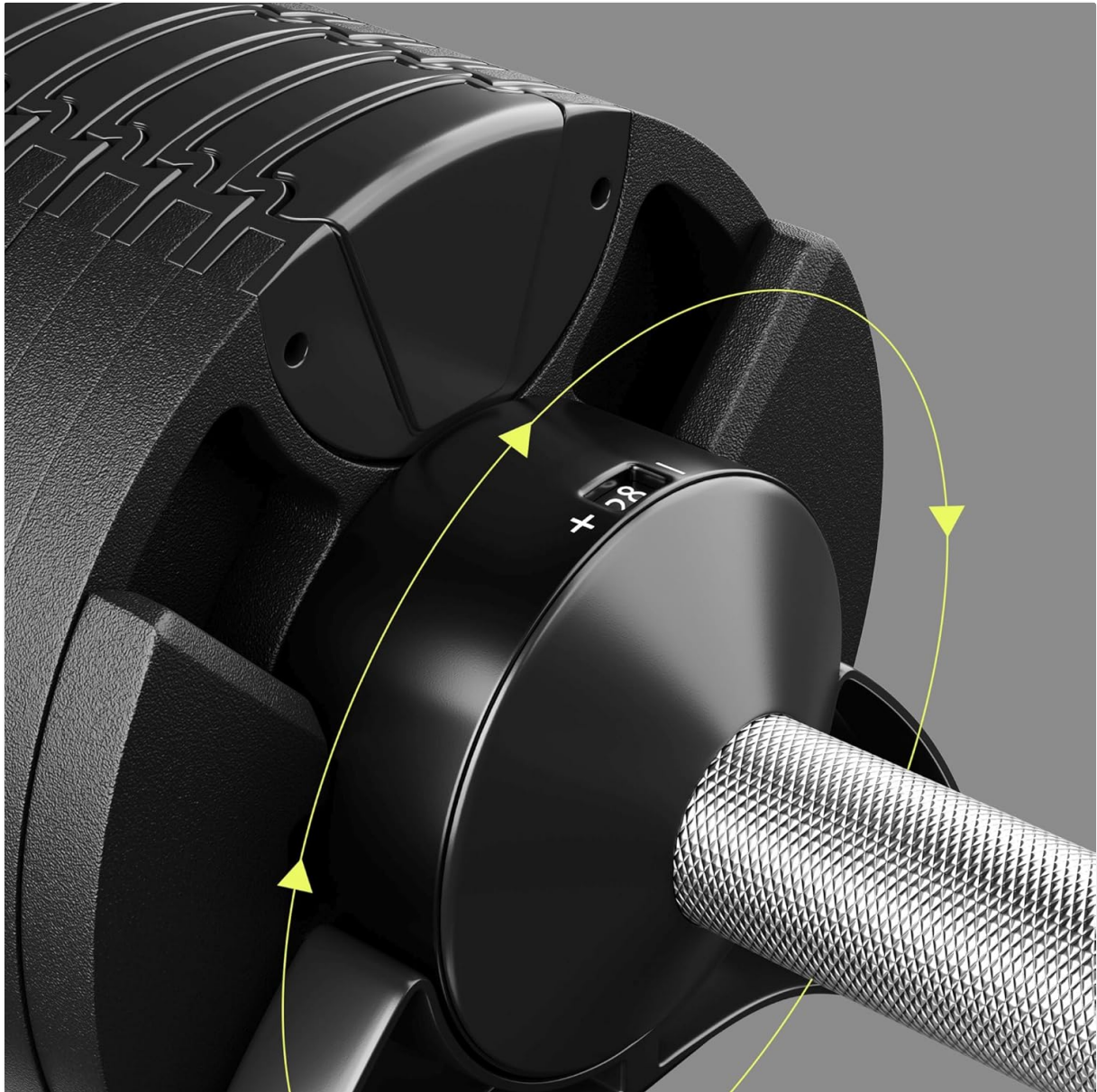

Figure 5.1: Rotating the weight selection dial to adjust the weight.



Figure 5.2: The double locking mechanism ensures plates are securely attached.

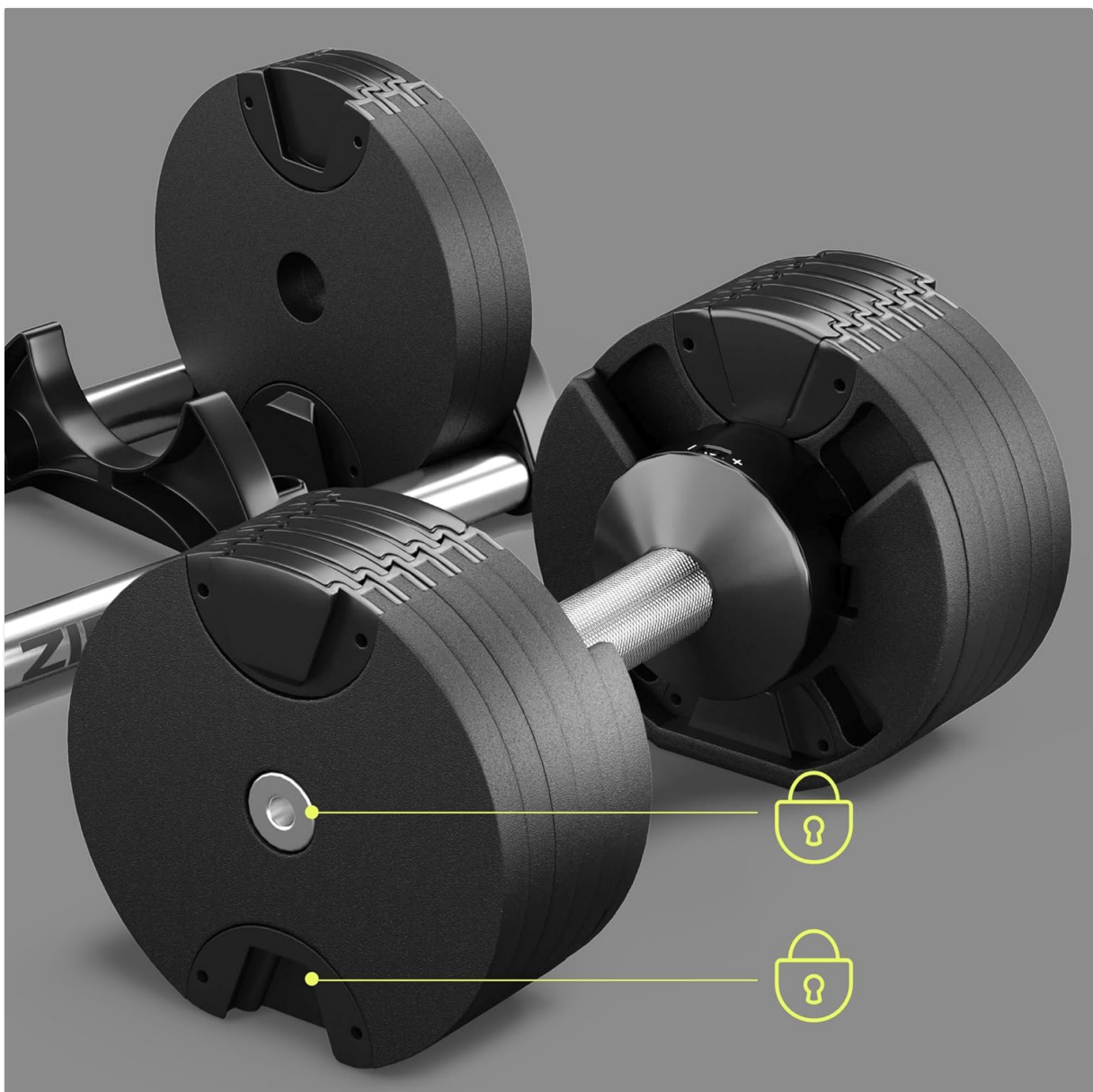

Figure 5.3: Visual representation of weight plate selection.

6. MAINTENANCE

Proper maintenance ensures the longevity and safe operation of your ZIPRO Adjustable Dumbbell.

- **Cleaning:** Wipe down the dumbbell and base with a damp cloth after each use to remove sweat and dust. Do not use abrasive cleaners or solvents.
- **Storage:** Store the dumbbell in its base in a dry, cool place, away from direct sunlight and extreme temperatures.
- **Regular Inspection:** Periodically check the weight selection mechanism and all moving parts for smooth operation. Ensure no debris is obstructing the plate selection.
- **Lubrication:** No lubrication is required for the weight adjustment mechanism.

7. TROUBLESHOOTING

Problem	Possible Cause	Solution
Dumbbell not lifting selected plates.	Weight selection dials not fully engaged or set to different weights.	Ensure both dials are set to the same weight and click into place. Push the dumbbell firmly into the base before lifting.
Dumbbell difficult to place back into the base.	Plates or handle misaligned.	Gently wiggle the dumbbell to align it with the unselected plates and the base. Do not force it.
Grinding noise during weight adjustment.	Debris in the mechanism or misalignment.	Inspect for any visible debris and remove it. Ensure the dumbbell is fully seated in the base when adjusting. If the issue persists, contact customer support.

8. SPECIFICATIONS

Brand: ZIPRO

Model: B0D1VTNJPC

Weight Range: 2.2 kg - 36 kg (16 adjustable settings)

Weight Increments: Approximately 2 kg per disk

Material: Alloy Steel, Polyvinyl Chloride (PVC)

Handle Diameter: 3.2 cm

Product Dimensions (L x W): 43.4 cm x 18.8 cm

Item Weight: 36000 Grams (36 kg)

Special Features: Adjustable load, Non-slip handle, Double locking system

Targeted Body Parts: Arms, Shoulders (and various other muscle groups depending on exercise)



Figure 8.1: Dimensions and weight settings for the 36 kg model.

9. WARRANTY AND SUPPORT

For warranty information or technical support, please refer to the documentation included with your purchase or contact ZIPRO customer service directly. Keep your proof of purchase for warranty claims.

Contact Information: Please visit the official ZIPRO website or refer to your purchase receipt for the most up-to-date customer support contact details.