

Manuals.plus /

› Wattive /

› Wattive GYAR9-AC-G 2P 40A Automatic Reclosing RCCB Circuit Breaker User Manual

Wattive GYAR9-AC-G

Wattive GYAR9-AC-G 2P 40A Automatic Reclosing RCCB Circuit Breaker User Manual

Model: GYAR9-AC-G

Brand: Wattive

1. PRODUCT OVERVIEW

The Wattive GYAR9-AC-G is an intelligent 2-pole, 40A Residual Current Circuit Breaker (RCCB) with an automatic reclosing function. Designed for AC230V systems, it features a digital display and a 300mA leakage protection value. This device automatically recloses the circuit after an accidental trip, reducing manual intervention and improving system efficiency. It supports both automatic and manual operating modes.

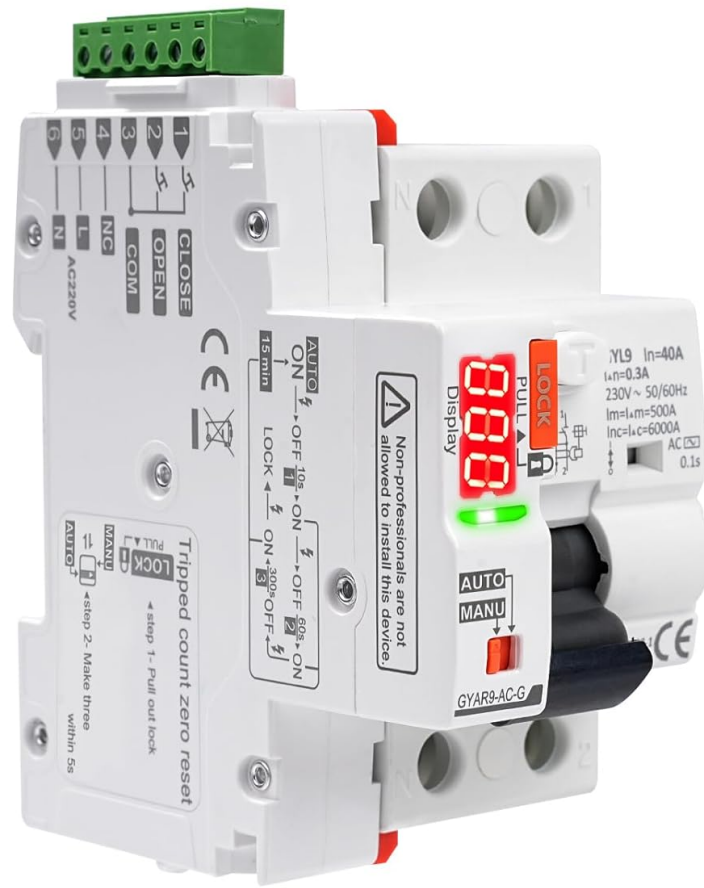

Image 1.1: Front view of the Wative GYAR9-AC-G Automatic Reclosing RCCB Circuit Breaker, showing its compact design, digital display, and control switches.

2. SAFETY INFORMATION

WARNING: Installation and maintenance of this device must be performed by qualified electricians only. Failure to follow these instructions can result in electric shock, fire, or serious injury.

- Always disconnect power before installing, wiring, or servicing the circuit breaker.
- Ensure proper grounding according to local electrical codes.
- Do not operate the device if it appears damaged.
- Verify all connections are secure and correct before restoring power.
- The device is designed for indoor use in environments within specified temperature and humidity ranges.

3. PRODUCT FEATURES

The GYAR9-AC-G circuit breaker incorporates several advanced features for enhanced safety and operational efficiency:

- **Intelligent Automatic Reclosing:** Automatically restores power after an accidental trip, minimizing downtime.
- **Automatic/Manual Switching:** Allows selection between automatic reclosing and manual restoration modes.
- **Self-Locking Mode:** Engages after multiple consecutive faults to ensure circuit safety before manual reset.
- **Digital LED Display:** Provides real-time status, fault codes, reclosing counts, and countdown timers.
- **High-Quality Construction:** Made from PC material with an IP20 protection grade.
- **DIN Rail Installation:** Compatible with standard 35mm DIN rails.

2P intelligent automatic reclosing device

- ✓ PC material, IP20 protection grade
- ✓ DIN rail installation (35 mm)
- ✓ Digital display with 3 digits
- ✓ Two switching modes
- ✓ LED indicator

GYAR9-AC-G(AC)

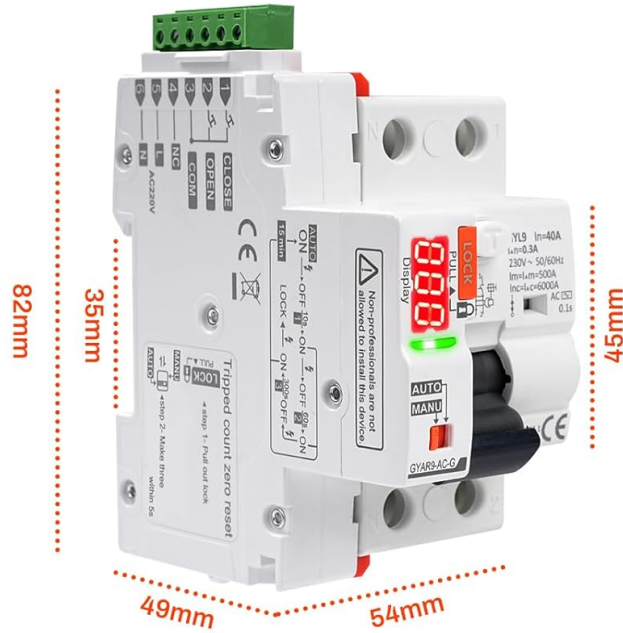

Image 3.1: Visual representation of the key features, including PC material, IP20 protection, DIN rail installation, digital display, two switching modes, and LED indicator.

4. SPECIFICATIONS

Parameter	Value
Material	Polycarbonate (PC)
Supply Voltage	AC 230V
Rated Current	40 A
Operating Frequency	50/60 Hz
Leakage Protection Value	300 mA
Control Signal	Automatic Reclosing + Dry Contact Control
Digital Display	3-digit interruption code, reclosing count, countdown
Effective Control Signal Duration	> 400 ms
Closing Time	< 1 s
Opening Time	< 0.5 s
Control Cable Length	≤ 1500 m
Power Consumption	≤ 1.5 VA (static), ≤ 25 VA (dynamic)
Rated Insulation Voltage	400 V
Rated Impulse Withstand Voltage (Uimp)	4 kV (4.9 kV at sea level)
Electrical Life	10,000 cycles, 3 cycles/min
Mechanical Life	10,000 cycles
Protection Class	IP20
Ambient Temperature	-25 to +70 °C
Storage Temperature	-40 to +70 °C
Wiring Capacity (Power/Control Terminals)	28-12 AWG (2.5 mm ²)
Wiring Capacity (Auxiliary Signal Terminals)	28-14 AWG (1.5 mm ²)
Mounting	DIN Rail EN 60715 (35 mm)
Dimensions (approx.)	12 x 11.5 x 9 cm
Weight (approx.)	351 grams

PRODUCT SIZE INFORMATION



Working frequency:	50/60Hz	Closing action time:	<1s
Control signal:	automatic reclosing dry contact control	Opening action time:	<0.5s
Digital display:	3-digit display of break CODE: (number of closing and opening, closing recovery countdown time)	Switching mode:	automatic/ manual switching
Effective control signal duration:	>400ms	Indicator light:	green normal state, red MCB overcurrent fault

Image 4.1: Detailed diagram showing the physical dimensions of the circuit breaker and a summary table of its key operational parameters.

5. INSTALLATION AND WIRING

The GYAR9-AC-G circuit breaker is designed for DIN rail mounting. Ensure all wiring is performed by a qualified professional in accordance with national and local electrical codes.

5.1. Mounting

1. Ensure the power supply to the distribution box is completely disconnected.
2. Attach the circuit breaker securely onto a standard 35mm DIN rail.

5.2. Wiring Diagram

Refer to the wiring diagram below for correct connection of the circuit breaker to the main power supply and loads. The diagram illustrates connections for the Line (L) and Neutral (N) inputs, as well as connections to multiple load circuits.

PRODUCT WIRING DIAGRAM

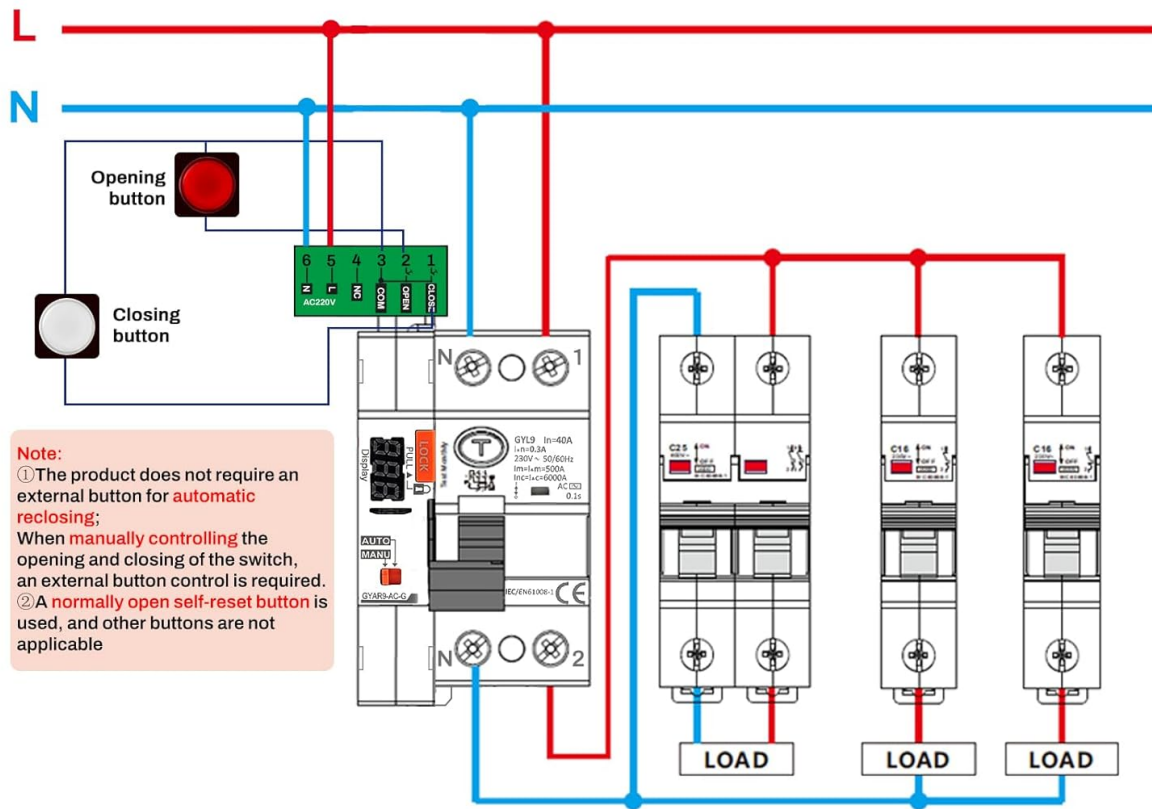

Image 5.1: Detailed wiring diagram showing the connection points for the main power supply (L, N), the circuit breaker, and multiple downstream loads. It also indicates optional external opening and closing buttons.

- Connect the main Line (L) and Neutral (N) wires to the designated terminals on the circuit breaker.
- Connect the load circuits to the output terminals.
- For manual control, an external normally open reset button can be connected to the auxiliary signal terminals (28-14 AWG, 1.5 mm²). The product does not require an external button for automatic reclosing.
- Ensure all connections are tight and properly insulated.

6. OPERATING INSTRUCTIONS

The GYAR9-AC-G offers both automatic and manual operating modes, selectable via a switch on the device.

6.1. Automatic/Manual Switching Modes

The device features an AUTO/MANU selector switch. The 'LOCK' mechanism prevents accidental operation when engaged.

- **AUTO Mode:** In this mode, the circuit breaker will automatically attempt to reclose after a fault trip.

The digital display will show a red flashing light when the gate is open and a green flashing light when the gate is closing.

- **MANU Mode:** In this mode, the circuit breaker requires manual restoration after a fault trip. The yellow light on the display will remain on for manual opening and closing.
- **LOCK Function:** When the 'LOCK' switch is engaged (pulled out), the circuit breaker cannot be closed, ensuring electrical safety during maintenance or inspection and preventing accidental contact.

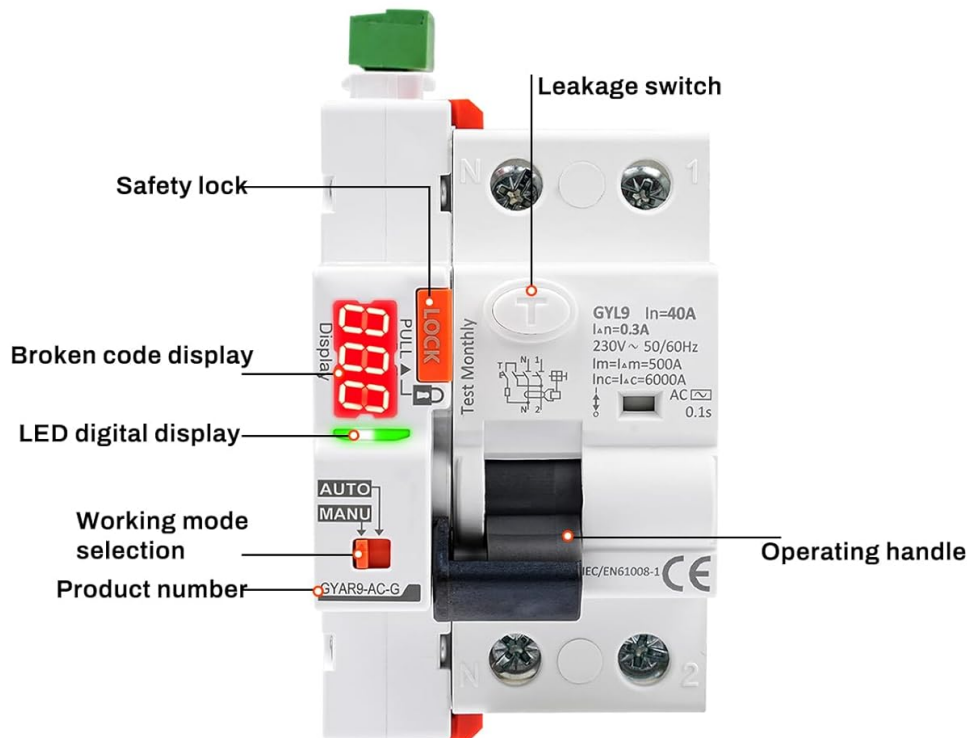

	Automatic/manual switching	LED digital display
In AUTO mode	the circuit breaker can be automatically restored after a fault.	red flashing indicates opening, green flashing indicates closing.
In MANU mode	the circuit breaker needs to be manually restored after a fault.	yellow light is always on for manual opening and closing. (The code shows the number of opening and closing times and the countdown time for closing recovery.)
Note: After the "LOCK" lock is turned on, the circuit breaker cannot be closed to protect the safety of electricity and prevent accidental touch.		

Image 6.1: Close-up view of the circuit breaker's controls, highlighting the leakage switch, safety lock, broken code display, LED digital display, working mode selection (AUTO/MANU), and operating handle. A table explains the automatic/manual switching and corresponding LED digital display behaviors.

6.2. Self-Locking Mode

To prevent continuous reclosing into a persistent fault, the device enters a self-locking mode after multiple consecutive trips:

1. **First Fault:** The circuit breaker automatically recloses after 9 seconds.
2. **Second Fault:** The circuit breaker automatically recloses after 59 seconds.
3. **Third Fault:** The circuit breaker automatically recloses after 299 seconds.
4. **Fourth Fault:** After the fourth consecutive fault, the recloser enters self-locking mode. Manual intervention is required. The circuit must be checked for safety, and then the gate must be manually

reopened.

After 40 seconds of self-locking, the device will automatically recover and be ready for manual or automatic operation again, provided the fault has been cleared.



SELF-LOCKING MODE

After a circuit fault occurs:

- 009 The first time, the circuit breaker will automatically close after 9 seconds;
- 059 The second time, the circuit breaker will automatically close after 59 seconds;
- 299 The third time, the circuit breaker will automatically close after 299 seconds;

After the fourth fault, the circuit breaker will be in self-locking mode. After checking the circuit safety, you need to manually close the circuit breaker again.











Waveform definition	Waveform	AC type	A type	Action range
				
Sinusoidal AC		√	√	0.5~1 IΔn
Pulsating DC		x	√	0.5~1.4 IΔn
Pulsating half-wave + DC (6mA)		x	√	max1.4 IΔn+6mA
Pulsating half-wave + DC (10mA)		x	x	max1.4 IΔn+10mA
High frequency (150Hz)		x	x	0.5~2.4 IΔn
High frequency (400Hz)		x	x	0.5~6 IΔn
High frequency (1000Hz)		x	x	1~14 IΔn
Two-phase full-wave rectification		x	x	0.5~2 IΔn
Three-phase full-wave rectification		x	x	0.5~2 IΔn
DC		x	x	0.5~2 IΔn

Image 6.2: Illustration of the self-locking mode, showing the digital display countdowns for the first three reclosing attempts and the final self-locking state after the fourth fault.

6.3. Digital Display Information

The 3-digit digital display provides critical operational feedback:

- **Interruption Code:** Displays a code indicating the type of interruption.
- **Reclosing Count:** Shows the number of times the circuit has been opened and reclosed.
- **Countdown Timer:** Indicates the remaining time until the next automatic reclosing attempt or recovery from self-locking mode.
- **LED Indicator:** Green for normal operation, red for MCB overcurrent error.

7. MAINTENANCE

Regular maintenance ensures the longevity and reliable operation of your circuit breaker.

- **Visual Inspection:** Periodically inspect the device for any signs of physical damage, discoloration, or loose connections.
- **Cleaning:** Keep the device clean and free from dust and debris. Use a dry, soft cloth for cleaning. Do not use liquid cleaners.
- **Test Button:** Press the 'Test Monthly' button (if available) regularly to verify the leakage protection function. Follow the instructions on the device for testing.
- **Professional Check:** Have a qualified electrician inspect the device and electrical system annually.

8. TROUBLESHOOTING

If the circuit breaker is not functioning as expected, consider the following:

- **Device in Self-Locking Mode:** If the device has tripped multiple times and is not reclosing, it may be in self-locking mode. Check the circuit for faults and manually reset the breaker.
- **No Power:** Verify the main power supply to the distribution box.
- **Incorrect Mode:** Ensure the AUTO/MANU switch is in the desired position. If in MANU mode, manual reset is required.
- **Persistent Fault:** If the breaker trips immediately after reclosing, there is a persistent fault in the circuit. Disconnect power and have a qualified electrician inspect the wiring and connected loads.
- **Digital Display Error:** Note any error codes displayed and consult a qualified electrician.

9. APPLICATION AREAS

The Wattive GYAR9-AC-G intelligent circuit breaker is suitable for a wide range of applications requiring reliable electrical protection and automatic fault recovery:

- Photovoltaic grid-connected AC distribution boxes
- Unmanned mobile phone base stations
- Elevators
- Smart homes
- Smart factories
- New energy vehicle charging stations

PRODUCT APPLICATION

It can be widely used in photovoltaic grid-connected AC distribution boxes, unmanned mobile phone base stations, elevators, smart homes, smart factories, new energy vehicle charging piles, etc.



Image 9.1: Collage of images depicting various application environments for the circuit breaker, including mobile phone base stations, solar power installations, electric vehicle charging points, and smart factory settings.

10. WARRANTY AND SUPPORT

Specific warranty information is not provided in this manual. Please refer to the product packaging or contact your retailer or the manufacturer, Wative, for details regarding warranty coverage and technical support.

For technical assistance or inquiries, please visit the official Wative website or contact their customer service department.