



Manuals.plus /

› NEVOSA /

› TPMS Sensors Set of 4 - tire pressure sensor Compatible with Hyundai Elantra 2017 2018 2019 2020 2021 2022 2023 2024 2025 Tucson Sonata Kona Venue Kia Sportage Sorento Soul Optima Replace# 52933-D4100

NEVOSA 52933-F2000 52933-D4100 52940-L1100

NEVOSA TPMS Sensor Instruction Manual

Model: 52933-F2000, 52933-D4100, 52940-L1100

1. INTRODUCTION

This manual provides essential information for the installation, operation, and maintenance of your NEVOSA Tire Pressure Monitoring System (TPMS) sensors. These sensors are designed to monitor your vehicle's tire pressure and temperature in real-time, enhancing driving safety and tire longevity. Each set includes four 433MHz sensors, pre-programmed for direct re-learn after installation.



Figure 1.1: NEVOSA TPMS Sensors (Set of 4) with packaging.

2. VEHICLE COMPATIBILITY

These TPMS sensors are compatible with a wide range of Hyundai, Kia, and Genesis models. It is crucial to verify the sensor frequency (433MHz) and part number against your vehicle's original sensor before purchase and installation. The compatible part numbers include 52933-F2000, 52933F2000, 52940AR100, 52940-AR100, 52940-T6000, 52940T6000, 52933-D9100, 52933D9100, 52933-D4100, 52933-D2100, 52933D2100, 52933D4100, 52940-L1100, and 52940L1100.

APPLICABLE MODELS

Compatible with Hyundai Models:

● 2017-2025	Elantra	● 2022-2025	Santa Cruz
● 2018-2021	Elantra GT	● 2017-2019	Santa Fe Sport
● 2016-2022	Ioniq	● 2020-2025	Sonata
● 2021-2024	Ioniq 5	● 2022-2025	Tucson
● 2023-2024	Ioniq 6	● 2019-2022	Veloster
● 2018-2025	Kona	● 2020-2025	Venue

Compatible with Kia Models:

● 2017-2021	Cadenza	● 2016-2021	Optima
● 2022-2025	Carnival	● 2021-2025	Seltos
● 2025	K4	● 2018-2024	Sorento
● 2021-2025	K5	● 2020-2025	Soul
● 2017-2023	Niro	● 2016-2025	Sportage

Compatible with Genesis Models:

● 2021-2025	G80	● 2022-2025	GV70
● 2017-2022	G90	● 2021-2025	GV80

Figure 2.1: Applicable Vehicle Models List.

Compatible Models List:

- **Hyundai:** Elantra (2017-2025), Elantra GT (2018-2021), Ioniq (2016-2022), Ioniq 5 (2021-2024), Ioniq 6 (2023-2024), Kona (2018-2025), Santa Cruz (2022-2025), Santa Fe (2017-2019), Sonata (2020-2025), Tucson (2022-2025), Veloster (2019-2022), Venue (2020-2025).
- **Kia:** Cadenza (2017-2021), Carnival (2022-2025), K4 (2025), K5 (2021-2025), Niro (2017-2022), Optima (2016-2021), Seltos (2021-2025), Sorento (2018-2025), Soul (2020-2025), Sportage (2016-2025).
- **Genesis:** G80 (2021-2025), G90 (2017-2022), GV70 (2022-2025), GV80 (2021-2025).

Always confirm compatibility by checking your vehicle's specific requirements and the sensor's part number and frequency (433MHz).

3. PRODUCT FEATURES

- **High Integration Chip (SNP739D):** Equipped with a high-precision, highly integrated SNP739D chip, these sensors incorporate multiple built-in sensors to accurately measure pressure, acceleration, temperature, and battery voltage. An interval timer controls data measurement and transmission, optimizing power consumption.



Figure 3.1: High Integration SNP739D Chip.

- **Durable Design:** Constructed from high-grade materials, NEVOSA TPMS sensors are built to withstand harsh driving and weather conditions, including extreme heat, cold, and corrosion. Their robust design ensures reliable performance and long-term durability, exceeding OEM standards.
- **Extended Battery Life:** Featuring original Japanese imported batteries, these tire sensors offer a lifespan of 5-7 years under normal operating conditions. Energy-saving technology further preserves power when the sensor is not actively in use, ensuring consistent operation without frequent replacements.
- **Real-Time Monitoring:** The sensors provide continuous, real-time monitoring of tire pressure and temperature, transmitting data to your vehicle's system. This allows for immediate alerts in case of significant pressure drops or temperature increases, contributing to safer driving.

REAL TIME MONITORING



Temperature Monitoring



Pressure Monitoring



High/Low pressure alarm



Figure 3.2: Real-Time Monitoring Capability.

- **Adjustable Angle Valve Stem:** The sensor features a 30-degree adjustable angle, making it suitable for a wider range of car models and wheel designs. The aluminum alloy valve stem provides durability and prevents dust and corrosion.

**SNP739D CHIP WITH
MULTIPLE BUILT-IN SENSORS**

High-precision, Highly integrated

**CR2032 ORIGINAL JAPANESE
IMPORTED BATTERY**

Battery Life 5-7 Years



STRUCTURE DIAGRAM

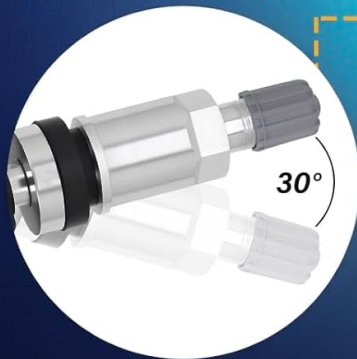

**30° ADJUSTABLE
ANGLE**

Suitable for more car models and wheels

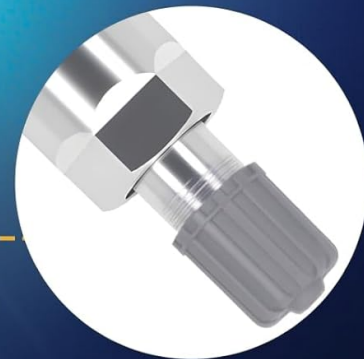

**ALUMINUM ALLOY
VALVE STEM**

Dust and corrosion prevention

Figure 3.3: Sensor Structure Diagram.

4. SETUP AND INSTALLATION

4.1 Pre-Installation Checks

Before installing the TPMS sensors, it is essential to confirm that you have the correct sensors for your vehicle. Verify the frequency (433MHz) and the part number of your original sensor. If unsure, provide your car's VIN or model and year to a qualified technician for confirmation.

CUSTOMER NOTICE

1 Before you buy TPMS sensor

Please check your original sensor part number and frequency, make sure your original sensor is same with our sensor

if you are not sure, please send us your car VIN or car model and year

2 After you buy TPMS Sensor

Please Do Not start a sensor replacement job if TPMS tool Can Not detect our sensor to display information such as sensor ID, frequency, battery status and PSI.

Pre-programmed TPMS sensors require relearn procedure to connect with car's ECU system to send information.

If you have any problem about the TPMS Sensor, please contact us for support

Figure 4.1: Important Customer Notice.

4.2 Installation Procedure

TPMS sensor installation typically requires specialized tools and expertise. It is highly recommended to have these sensors installed by a certified automotive technician. Do not attempt sensor replacement if your TPMS tool cannot detect your sensor or display information such as sensor ID, frequency, battery status, and PSI.

4.3 Relearn Procedure (TPMS Tool Required)

After installation, the pre-programmed TPMS sensors require a re-learn procedure to connect with your car's ECU system and transmit information. This process typically involves using a TPMS scan tool.

1. Properly install tire pressure sensors in each wheel. Ensure all tires are inflated to the pressure listed on the tire placard.
2. Starting with the Left Front (LF) tire, use the OBD II tool to trigger each sensor in the following order: LF, RF, RR, LR.
3. Turn ignition to ON position.
4. Connect OBD tool to OBD II port then write sensor IDs.
5. Switch off, then switch on the ignition. Test drive above 19 mph (30km/h) for at least 10 minutes. Ensure the tire pressure monitor system works correctly (TPMS light off).

Note: OBDII Relearn Procedure is the most effective way for vehicles to connect new sensors.

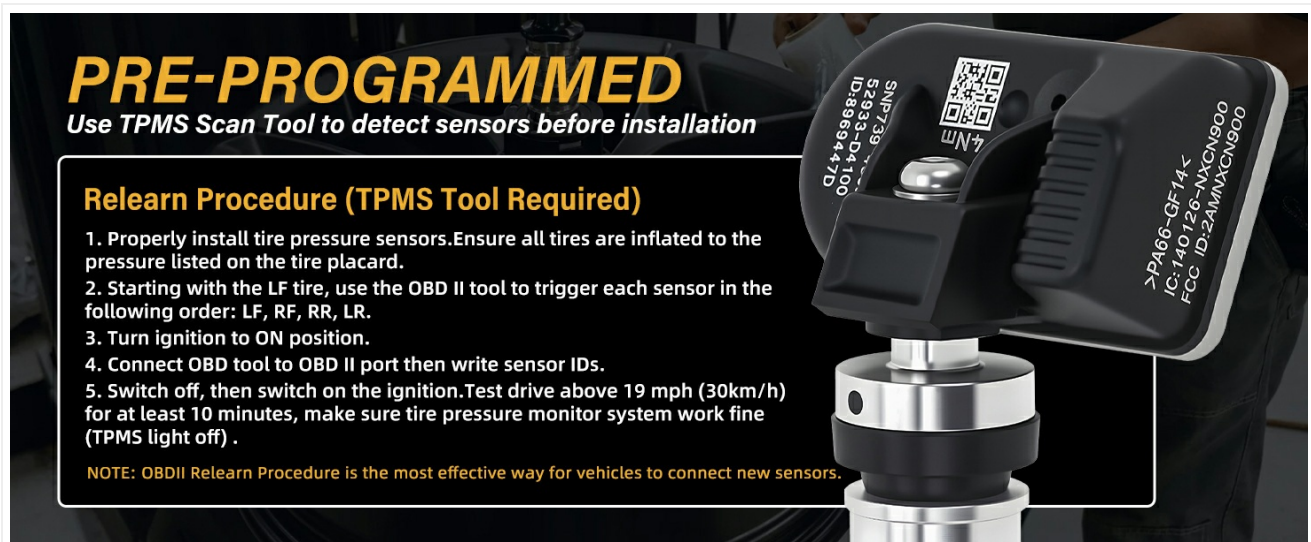

Figure 4.2: Pre-programmed Sensor Relearn Procedure.

5. OPERATING INSTRUCTIONS

Once properly installed and re-learned, your NEVOSA TPMS sensors will continuously monitor the air pressure and temperature within your vehicle's tires. This data is transmitted wirelessly to your vehicle's onboard computer system, which then displays the information on your dashboard or alerts you to any significant deviations from recommended levels.

- **Pressure Monitoring:** The system will alert you if a tire's pressure falls below a safe threshold or rises excessively.
- **Temperature Monitoring:** Sensors also monitor tire temperature, which can indicate potential issues like overheating due to underinflation or mechanical problems.
- **Alarm System:** In case of high/low pressure or abnormal temperature, an alarm or warning light will activate on your vehicle's dashboard, prompting you to take corrective action.

6. MAINTENANCE

NEVOSA TPMS sensors are designed for durability and long-term performance with minimal maintenance. However, proper tire care is essential for the longevity and accuracy of your TPMS system:

- **Regular Tire Pressure Checks:** Even with TPMS, it is advisable to manually check your tire pressure regularly with a reliable gauge.
- **Professional Tire Service:** When tires are rotated, repaired, or replaced, ensure that the TPMS sensors are handled by qualified technicians to prevent damage.
- **Valve Stem Care:** The aluminum alloy valve stems are designed to resist corrosion. However, avoid using harsh chemicals or abrasive cleaners on them.

7. TROUBLESHOOTING

If you encounter issues with your NEVOSA TPMS sensors, consider the following common scenarios:

- **Sensor Not Detected / TPMS Light On:**
 - Ensure the re-learn procedure (Section 4.3) has been correctly performed.
 - Verify that your TPMS tool can detect the sensor and display its ID, frequency, battery status, and PSI. If not, the sensor may not be properly installed or may be faulty.
 - Check tire pressure to ensure it matches the vehicle's recommended levels.

- **Inaccurate Readings:**

- Confirm that tires are inflated to the correct pressure according to your vehicle's specifications.
- Ensure the sensors are correctly installed and seated within the tire.

- **Sensor Battery Life:** While designed for 5-7 years, extreme conditions or continuous high usage might affect battery life. If a sensor consistently fails to transmit data, its battery may be depleted.

If you have any problems with the product that cannot be resolved with the above steps, please contact customer service for assistance.

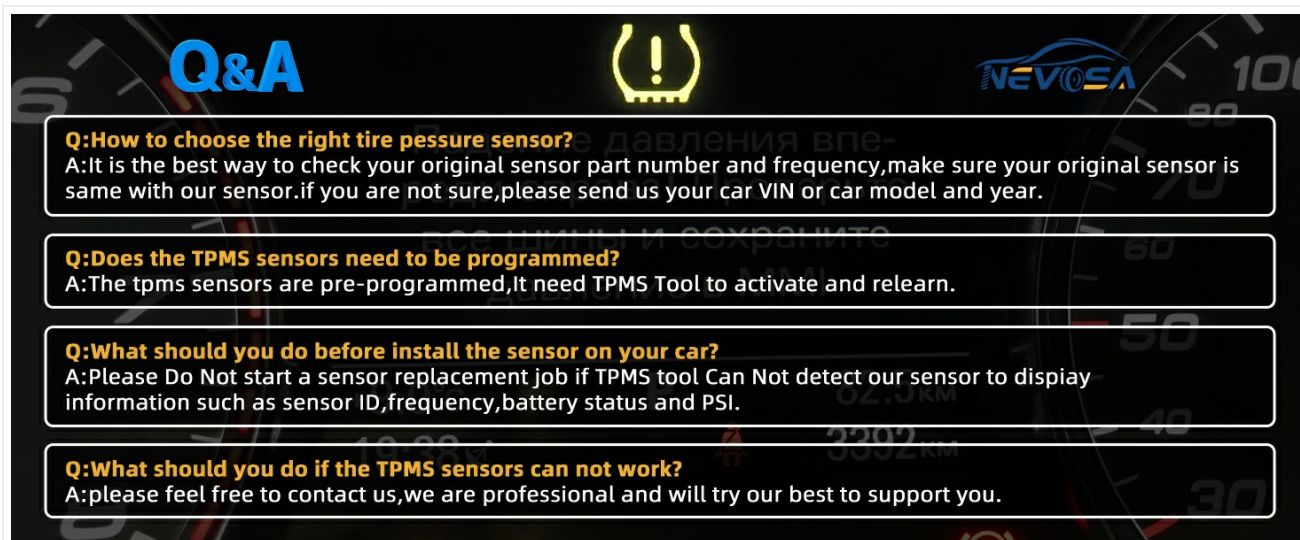

Figure 7.1: Common Questions and Answers.

8. SPECIFICATIONS

Attribute	Detail
Model Numbers	52933-F2000, 52933-D4100, 52940-L1100
Frequency	433MHz
Chip	SNP739D (High-precision, highly integrated)
Battery Type	CR2032 (Japanese imported, included)
Estimated Battery Life	5-7 years (under normal conditions)
Operating Temperature	-40 to 125 Degrees Celsius
Valve Stem	Aluminum Alloy, 30° Adjustable Angle
Item Weight (per sensor)	Approximately 5.6 ounces (total for 4 sensors)
Package Dimensions	3.74 x 2.75 x 1.97 inches
Manufacturer	NEVOSA

9. WHAT'S IN THE BOX

Your NEVOSA TPMS Sensor package includes:

- 4 x NEVOSA Tire Pressure Monitoring System Sensors (433MHz)

PACKAGE CONTENT



Figure 9.1: Package Content.

10. WARRANTY AND CUSTOMER SUPPORT

10.1 Warranty Information

NEVOSA offers a **1-year warranty** on these TPMS sensors. This warranty covers manufacturing defects and ensures reliable product performance under normal use conditions.

10.2 Customer Support

If you encounter any issues with your NEVOSA TPMS sensors or have questions regarding their installation, operation, or compatibility, please do not hesitate to contact our customer service team. We are committed to providing prompt and effective solutions to ensure your satisfaction.

For support, please refer to the contact information provided with your product packaging or visit the official NEVOSA website.

