

Manuals+

[Q & A](#) | [Deep Search](#) | [Upload](#)

Manuals.plus /

› [PINDOWS](#) /

› PINDOWS Digital Sport Watch PDS-8021 User Manual

PINDOWS PDS-8021

PINDOWS Digital Sport Watch PDS-8021 User Manual

Model: PDS-8021

1. PRODUCT OVERVIEW

The PINDOWS Digital Sport Watch PDS-8021 is designed for active individuals, offering a clear digital display, robust 5ATM water resistance, and multiple functions including a stopwatch, alarm, and dual time. Its transparent case and bright LED backlight enhance usability and style.

LED BACKLIGHT

combined with a transparent case, can easily illuminate the watch



Figure 1: PINDOWS Digital Sport Watch PDS-8021

Key Features:

- Digital Time Display (12/24-hour format)
- Date Display
- Stopwatch Function
- Daily Alarm
- Hourly Chime
- Dual Time Zone
- Bright LED Backlight
- 5ATM Water Resistance

FUNCTIONAL OVERVIEW



Figure 2: Functional Overview and Button Layout

Button Functions:

- **LIGHT Button (Top Left):** Activates the LED backlight.
- **MODE Button (Bottom Left):** Cycles through display modes (Time, Stopwatch, Alarm, Dual Time).
- **START/PAUSE Button (Top Right):** Starts/pauses stopwatch, adjusts values in setting mode.
- **RESET/ADJUSTMENT Button (Bottom Right):** Resets stopwatch, selects items to adjust in setting mode.

2. INITIAL SETUP

Your watch comes with the battery pre-installed and active. Follow these steps to set the time and other functions.

2.1 Setting Time and Date:

1. From the normal time display, press the **MODE** button three times to enter Time Setting mode. The seconds will flash.
2. Press the **RESET/ADJUSTMENT** button to cycle through the settings: Seconds → Hour → Minute → Month

→ Date → Day of Week.

3. While a value is flashing, use the **START/PAUSE** button to increase the value. Hold the button to increase rapidly.
4. To switch between 12-hour and 24-hour (military) format, press the **RESET/ADJUSTMENT** button until the hour is flashing. Then, press the **START/PAUSE** button to toggle between 'A' (AM), 'P' (PM) for 12-hour format, or 'H' for 24-hour format.
5. Once all settings are correct, press the **MODE** button to exit Time Setting mode and return to the normal time display.

2.2 Setting the Alarm:

1. From the normal time display, press the **MODE** button twice to enter Alarm Setting mode. The hour digits will flash.
2. Press the **START/PAUSE** button to set the desired alarm hour.
3. Press the **RESET/ADJUSTMENT** button to select the minute digits. The minute digits will flash.
4. Press the **START/PAUSE** button to set the desired alarm minute.
5. Press the **MODE** button to exit Alarm Setting mode.
6. To activate/deactivate the alarm, press and hold the **START/PAUSE** button, then press the **RESET/ADJUSTMENT** button. An alarm icon will appear/disappear.

2.3 Setting Dual Time:

1. From the normal time display, press the **MODE** button four times to enter Dual Time Setting mode. The hour digits will flash.
2. Press the **START/PAUSE** button to set the desired hour for the second time zone.
3. Press the **RESET/ADJUSTMENT** button to select the minute digits. The minute digits will flash.
4. Press the **START/PAUSE** button to set the desired minute for the second time zone.
5. Press the **MODE** button to exit Dual Time Setting mode.

2.4 Hourly Chime:

To activate or deactivate the hourly chime, press and hold the **MODE** button, then press the **RESET/ADJUSTMENT** button. A chime icon will appear/disappear on the display.

3. OPERATING INSTRUCTIONS

3.1 Using the Stopwatch:

1. From the normal time display, press the **MODE** button once to enter Stopwatch mode. The display will show '00:00:00'.
2. Press the **START/PAUSE** button to start the stopwatch.
3. Press the **START/PAUSE** button again to pause the stopwatch.
4. To resume, press the **START/PAUSE** button.
5. To reset the stopwatch to zero, ensure it is paused, then press the **RESET/ADJUSTMENT** button.
6. Press the **MODE** button to exit Stopwatch mode.

3.2 Activating the LED Backlight:

Press the **LIGHT** button (top left) to illuminate the display. The backlight will remain on for a few seconds.



Figure 3: LED Backlight in action

3.3 Water Resistance (5ATM):

The watch is rated 5ATM (50 meters) water resistant. This means it is suitable for:

- Cold water rinse
- Washing hands
- Swimming
- Sweating

Important: Do not press any buttons while the watch is submerged in water. Avoid hot water, steam, or diving, as this can compromise the water resistance seals.

50m water resistance for daily life



- Cold water rinse
- Swim
- Wash hands
- Sweat

Figure 4: Watch demonstrating 50m water resistance

4. MAINTENANCE

4.1 Cleaning:

Wipe the watch case and strap with a soft, damp cloth. For stubborn dirt, a mild soap solution can be used, followed by rinsing with clean water and drying thoroughly. Avoid harsh chemicals or abrasive materials.

4.2 Battery Replacement:

When the display dims or functions become erratic, the battery may need replacement. This watch uses a standard watch battery. It is recommended to have the battery replaced by a qualified watch technician to ensure proper sealing and maintain water resistance.

4.3 Storage:

Store your watch in a cool, dry place away from direct sunlight, extreme temperatures, and strong magnetic fields when not in use.

5. TROUBLESHOOTING

Common Issues and Solutions:

- **Difficulty Setting Time/Date:** Ensure you are in the correct setting mode (press **MODE** three times for time/date). Use the **RESET/ADJUSTMENT** button to select the flashing item and the **START/PAUSE** button to change its value. If the watch appears unresponsive, try pressing the **LIGHT** button to ensure it's not in a locked state, then re-attempt the setting process.
- **Watch Stuck in Military Time (24-hour format):** When setting the hour, repeatedly press the **START/PAUSE** button. The display should cycle through AM/PM indicators (for 12-hour format) and then to the 24-hour format. If it only shows 24-hour format, ensure you are pressing the **START/PAUSE** button when the hour is flashing, and continue cycling through until AM/PM appears if desired.
- **Buttons Unresponsive:** Check if the watch is wet, as buttons should not be pressed underwater. If dry and still unresponsive, a soft reset might be needed (remove and reinsert battery, recommended by a professional).
- **Display is Dim or Blank:** This usually indicates a low battery. Refer to section 4.2 for battery replacement.
- **Inaccurate Time:** If the time is consistently inaccurate, the battery may be low, or the watch may require servicing.

6. SPECIFICATIONS

PRODUCT PARAMETERS

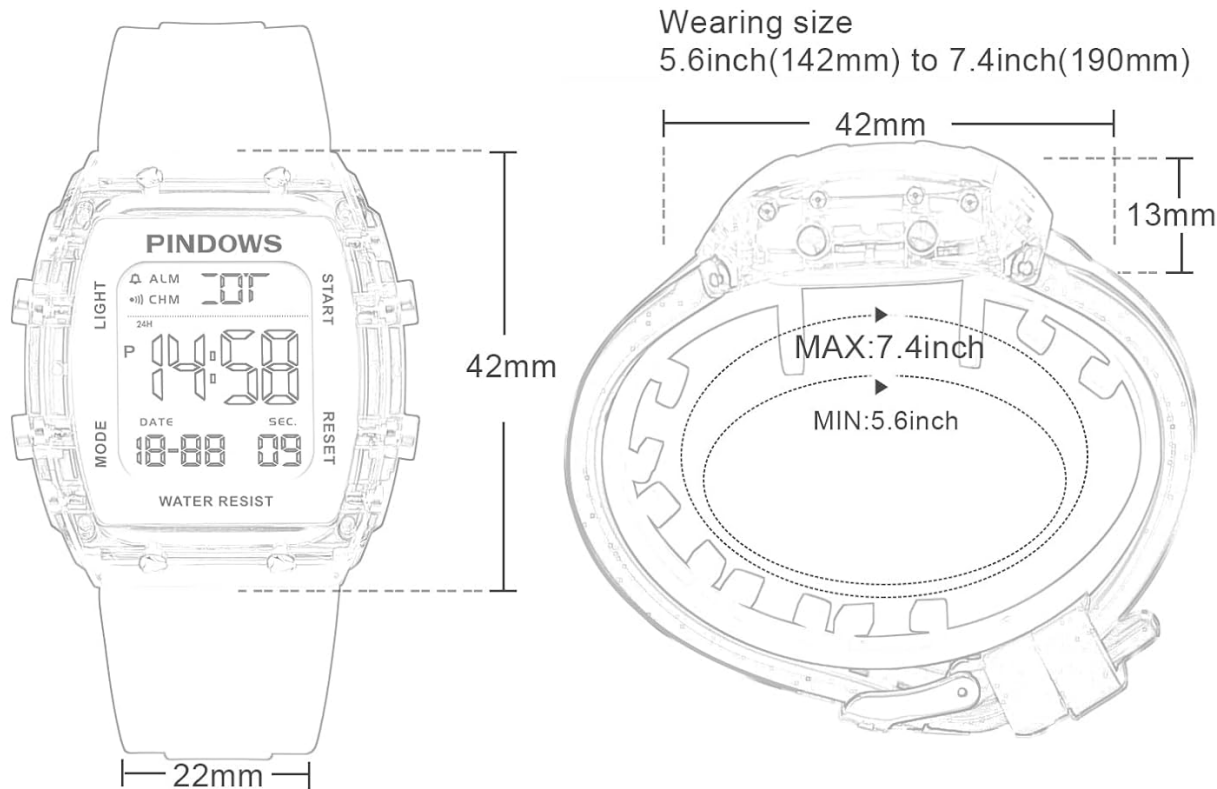

Weight: 50g	Band Material: Skin-friendly silicone
Case Material: ABS	Bottom Cover Material: Stainless Steel

 Case Diameter: 1.65inch/42mm	 Band Width: 0.86inch/22mm
 Case Thickness: 0.51inch/13mm	 Band Length: 5.6inch-7.4inch

Figure 5: Product Dimensions and Materials

Feature	Specification
Model Name	PDS-8021
Display Type	Digital
Watch Movement Type	Japanese Quartz
Water Resistance Depth	50 Meters (5ATM)
Band Material Type	Silicone
Case Material Type	Acrylonitrile Butadiene Styrene (ABS)
Case Diameter	42 Millimeters
Band Width	22 Millimeters
Case Thickness	13 Millimeters

Item Weight	0.12 Kilograms (120g)
Power Source Type	Battery Powered

7. WARRANTY AND SUPPORT

7.1 Manufacturer's Warranty:

This PINDOWS Digital Sport Watch PDS-8021 comes with a **1 Year Manufacturer Warranty** from the date of purchase. This warranty covers manufacturing defects under normal use. It does not cover damage caused by misuse, accidents, unauthorized repairs, or normal wear and tear.

7.2 Contact Information:

For warranty claims or technical support, please contact the manufacturer:

Manufacturer: Guangzhou Zhangbeila Maoyi Youxian Zeren Gongsi

Address: Room 202, 2F, Building A, No. 17 Jiangshi East Road, Jianggao Town, Baiyun District, Guangzhou, Guangdong, China, 51000

Telephone: 19587493862