

Manuals+

[Q & A](#) | [Deep Search](#) | [Upload](#)

manuals.plus /

› [ULTIMEA](#) /

› [ULTIMEA Poseidon M60 5.1ch Soundbar User Manual](#)

ULTIMEA U3721

ULTIMEA Poseidon M60 5.1ch Soundbar User Manual

Model: U3721

INTRODUCTION

This manual provides comprehensive instructions for the setup, operation, and maintenance of your ULTIMEA Poseidon M60 5.1ch Soundbar. Please read this manual thoroughly before using the product to ensure proper functionality and safety.



Image: The ULTIMEA Poseidon M60 soundbar and wired subwoofer positioned in front of a television, illustrating a typical home theater setup.

PACKAGE CONTENTS

Before proceeding with the setup, please verify that all items listed below are included in your package:

- 1x Soundbar
- 1x Wired Subwoofer
- 1x Power Adaptor
- 1x HDMI Cable
- 1x Remote Control (Batteries Not Included)
- 2x Wall Brackets
- 2x Mounting Screws
- 4x Wall Mounted Kit

SETUP

1. Soundbar Assembly

The soundbar is designed in two sections for compact packaging. To assemble, align the two sections and twist them together until they securely interlock. Ensure a firm connection for optimal audio performance.

2. Placement

The ULTIMEA Poseidon M60 can be placed on a tabletop or mounted on a wall. For optimal sound dispersion, position the soundbar centrally below your television. The wired subwoofer should be placed on the floor, ideally in a corner or near a wall to enhance bass response.

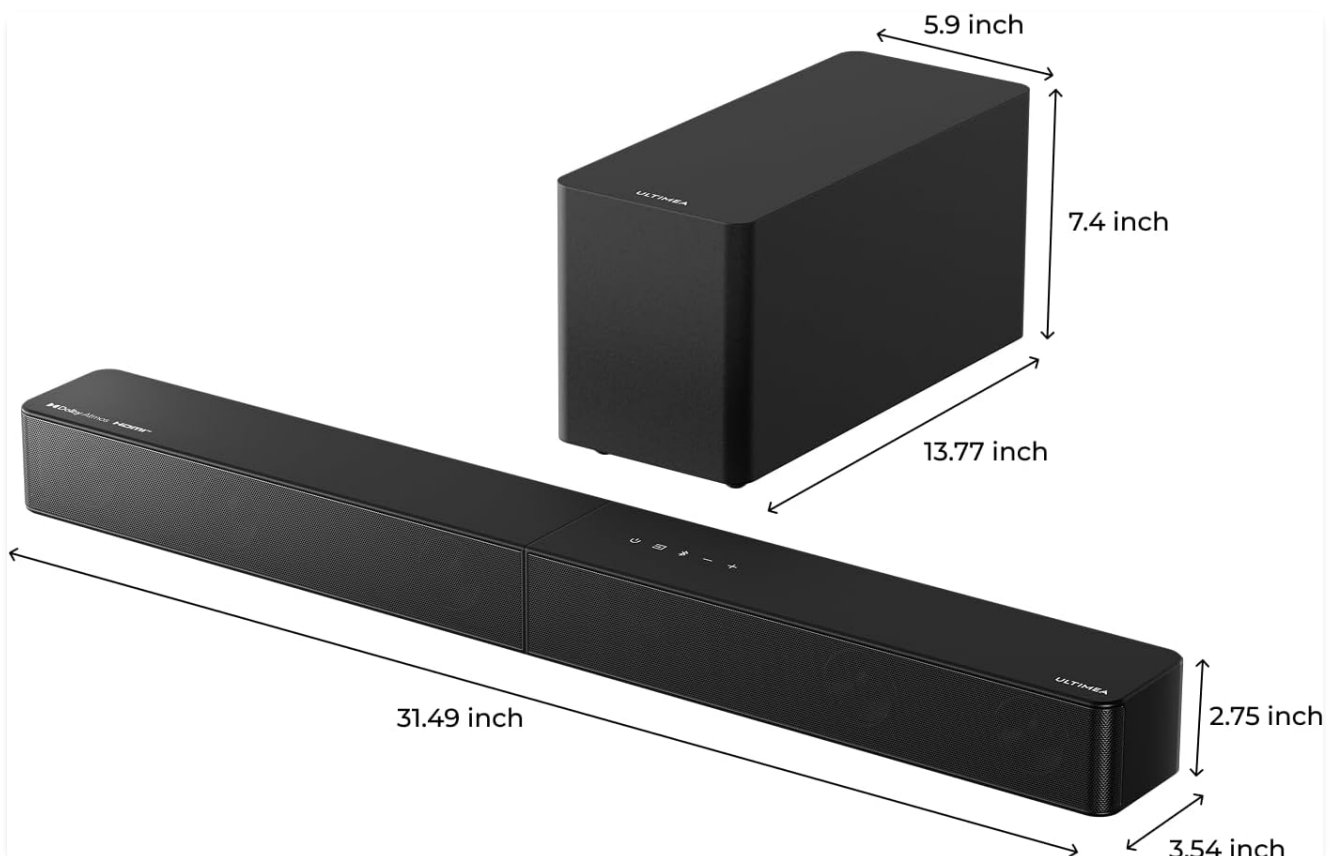

Image: Detailed dimensions of the ULTIMEA Poseidon M60 soundbar (31.49 inches long, 3.54 inches deep, 2.75 inches high) and its wired subwoofer (13.77 inches deep, 5.9 inches wide, 7.4 inches high).

3. Connections

Connect the soundbar to your television using the provided HDMI eARC cable for the best audio experience, including Dolby Atmos support. Alternatively, you can use an optical cable. Connect the wired subwoofer to the soundbar using the dedicated SUB OUT port. Finally, connect the power adaptor to the soundbar and plug it into a power outlet.



Image: A close-up of the soundbar's rear panel, highlighting the HDMI eARC port and the connection of an HDMI cable, indicating support for lossless, high-fidelity audio transmission.

For seamless control, ensure your TV's HDMI-CEC feature is enabled, allowing your TV remote to control basic soundbar functions.

OPERATING INSTRUCTIONS

Power On/Off

Press the power button on the soundbar or the remote control to turn the unit on or off.

Input Selection

Use the input selection button on the remote or soundbar to switch between HDMI eARC, Optical, and Bluetooth 5.4 inputs.

Volume Control

Adjust the volume using the '+' and '-' buttons on the remote control or the soundbar's top panel.

Bluetooth Pairing

To pair a Bluetooth device, select the Bluetooth input. The soundbar will enter pairing mode. On your device, search for "ULTIMEA Poseidon M60" and select it to connect. The soundbar features upgraded Bluetooth 5.4 for ultra-low latency and stable connections.

Audio Modes and Customization

The soundbar offers various audio presets and customization options to enhance your listening experience:

- **Dolby Atmos:** Experience immersive, multi-dimensional sound with true Dolby Atmos support. The soundbar's five built-in full-range drivers, including side-firing units, create a spacious, cinematic atmosphere.
- **VoiceMX:** This feature enhances dialogue clarity, ensuring voices are loud and clear across all content types.
- **BassMX:** The 5.25" subwoofer with a 16mm long-excursion driver and 5.3L acoustic chamber provides deep, responsive bass.

5.1 Channel Dolby Atmos Soundbar



 **Dolby Atmos**

Image: An illustration showing sound waves emanating from the ULTIMEA Poseidon M60 soundbar and subwoofer, demonstrating the 5.1 channel Dolby Atmos surround sound experience filling a living room.

Crisp Vocals Powered by Dynamic EQ and Adaptive Gain



Image: A scene depicting two people conversing on a TV screen, with sound waves originating from the soundbar, illustrating the VoiceMX feature for crisp and clear dialogue.

ULTIMEA App Control

Download the ULTIMEA app to unlock advanced customization options. The app provides a 10-band graphic equalizer and 121 audio presets, allowing you to fine-tune the sound to your preference. The app also supports OTA (Over-The-Air) firmware updates for new features and optimal performance.

Fine-tune Your Sound with App Control



Image: Three smartphone screens displaying the ULTIMEA app interface, showing options for equalizer adjustments, style presets, and firmware updates, highlighting the comprehensive control available through the app.

Official Product Video

Your browser does not support the video tag.

Video: An official product video showcasing the ULTIMEA Poseidon M60 5.1ch Dolby Atmos Surround Sound System, demonstrating its features and immersive audio capabilities.

MAINTENANCE

To ensure the longevity and optimal performance of your ULTIMEA Poseidon M60 soundbar, follow these maintenance guidelines:

- **Cleaning:** Use a soft, dry cloth to wipe down the surfaces of the soundbar and subwoofer. Avoid using liquid cleaners or abrasive materials, as they may damage the finish or internal components.
- **Ventilation:** Ensure that the soundbar and subwoofer have adequate ventilation. Do not block any ventilation openings.
- **Environment:** Keep the unit away from direct sunlight, heat sources, excessive dust, moisture, and strong magnetic fields.
- **Power:** Disconnect the power cable from the wall outlet if the unit will not be used for an extended period.

TROUBLESHOOTING

If you encounter any issues with your ULTIMEA Poseidon M60 soundbar, please refer to the following common troubleshooting steps:

Problem	Possible Cause	Solution
No Sound	Power cable not connected. Incorrect input selected. Volume too low or muted. TV audio output settings incorrect.	Ensure power cable is securely connected. Select the correct input source (HDMI eARC, Optical, Bluetooth). Increase volume and check mute status. Adjust TV audio output to PCM or Bitstream, and ensure external speakers are selected.
No Bass from Subwoofer	Subwoofer not connected to soundbar. Subwoofer volume too low.	Verify the wired connection between the subwoofer and soundbar. Adjust bass levels via the remote or ULTIMEA app.
Bluetooth Pairing Issues	Soundbar not in pairing mode. Device too far from soundbar.	Ensure Bluetooth input is selected and soundbar is discoverable. Move Bluetooth device closer to the soundbar.

If the problem persists after trying these solutions, please contact ULTIMEA customer support.

SPECIFICATIONS

Feature	Detail
Model Name	Poseidon M60

Feature	Detail
Speaker Type	Soundbar
Surround Sound Channel Configuration	5.1
Audio Encoding	Dolby Atmos
Speaker Maximum Output Power	300 Watts (Peak)
Subwoofer Diameter	5.25 Inches
Subwoofer Connectivity Technology	Wired
Frequency Response	45 Hz
Connectivity Technology	HDMI eARC, Optical, Bluetooth 5.4
Wireless Communication Technology	Bluetooth 5.4
Control Method	App, Remote
Product Dimensions (Soundbar)	31.5"D x 3.54"W x 2.76"H
Item Weight	8.8 Pounds
Mounting Type	Tabletop or Wall Mount

One Sleek Bar with 5 Built-in Speakers

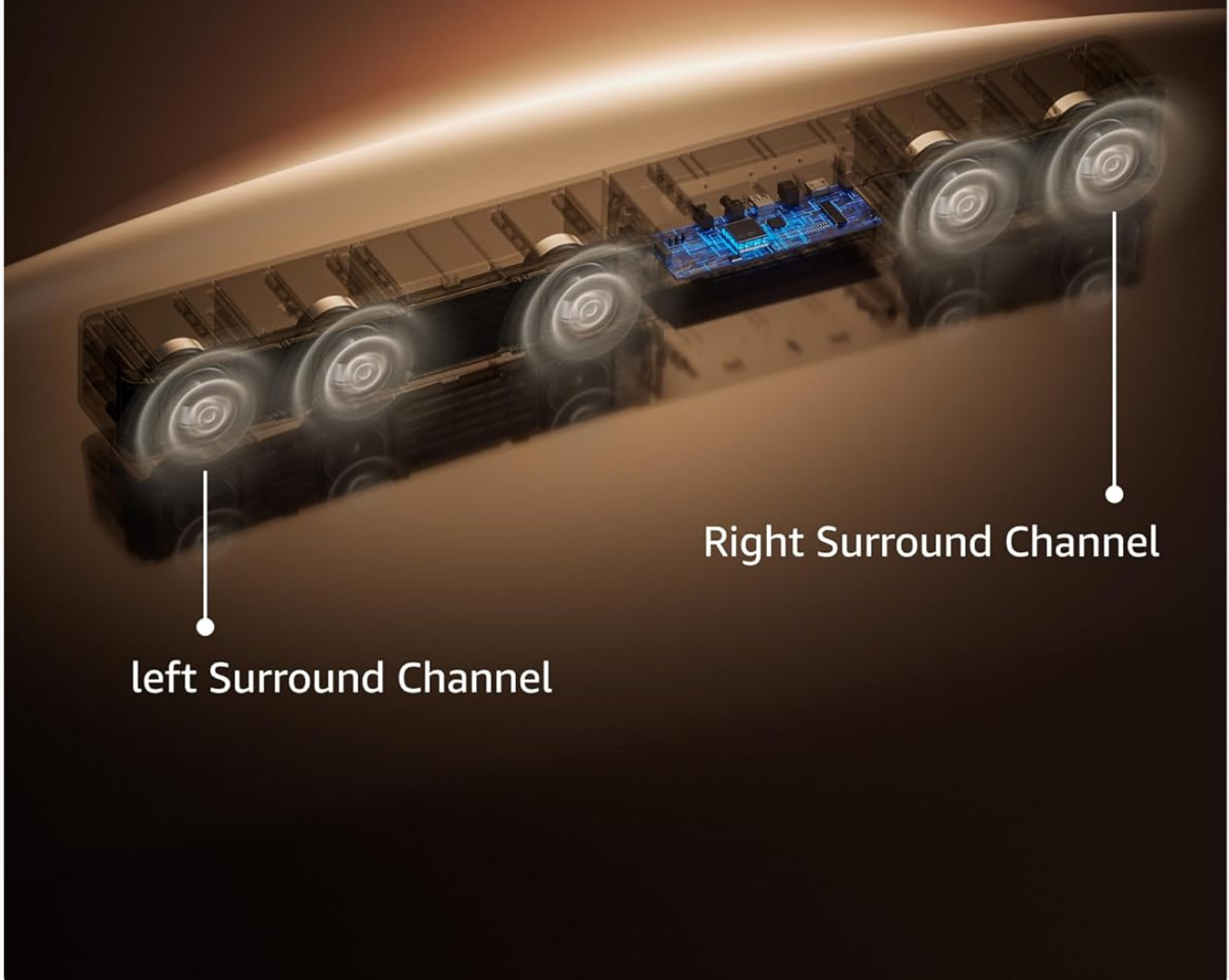

left Surround Channel

Right Surround Channel

Image: An X-ray view of the ULTIMEA Poseidon M60 soundbar, illustrating the internal arrangement of its five built-in speakers, including the left and right surround channels.

Oversized Cabinet for Bigger, Deeper Bass

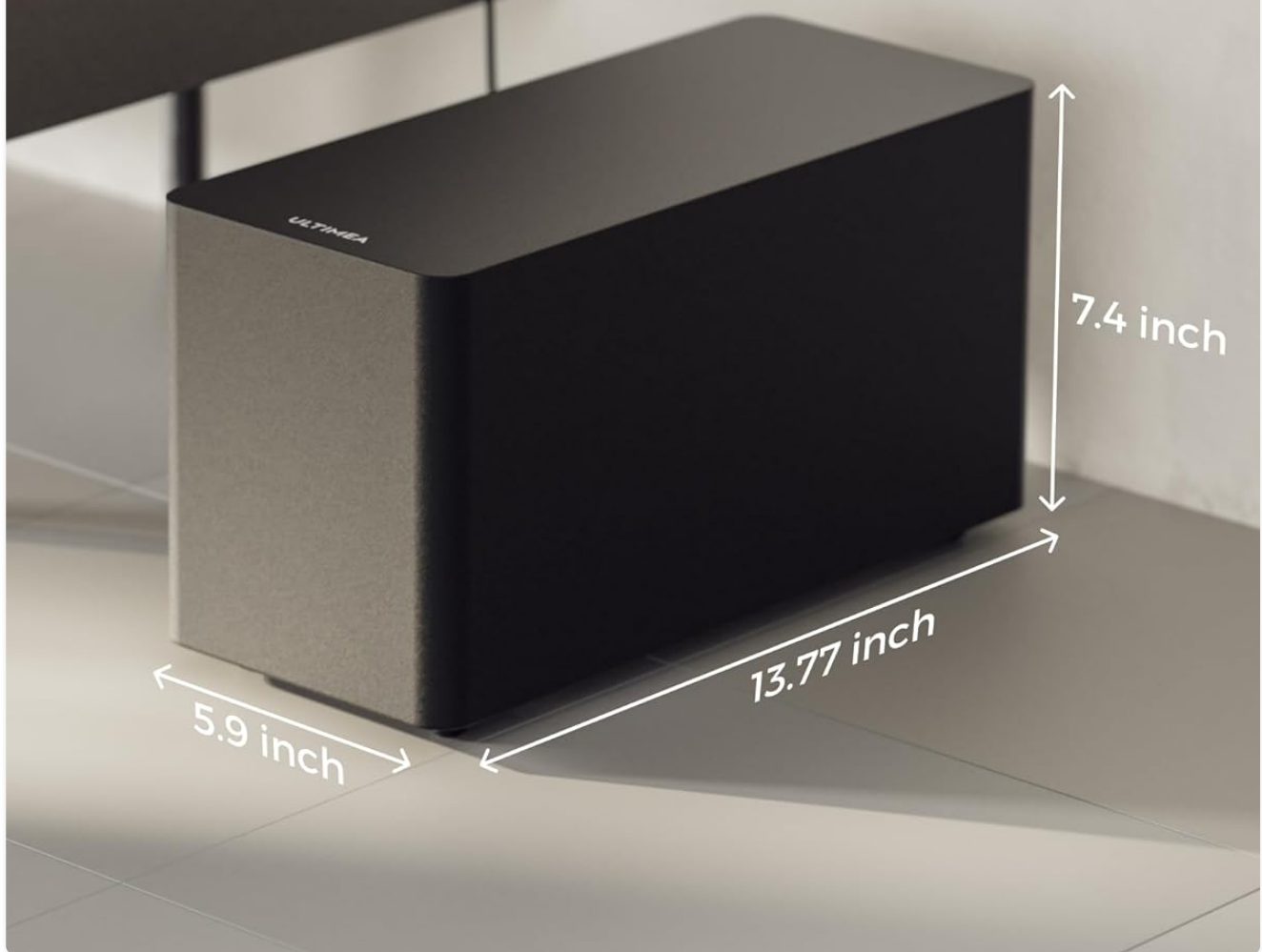

Image: The ULTIMEA Poseidon M60 subwoofer with its dimensions labeled: 13.77 inches deep, 5.9 inches wide, and 7.4 inches high, highlighting its compact yet powerful design.

16mm Bass-Boosting Excursion



Image: A detailed, stylized view of a speaker driver, emphasizing its 16mm bass-boosting excursion capability, which contributes to the subwoofer's deep low-frequency output.

WARRANTY AND SUPPORT

Warranty Information

ULTIMEA provides a worry-free warranty for its products. For specific warranty terms and conditions, please refer to

the warranty card included in your product packaging or visit the official ULTIMEA website.

Customer Support

For any technical assistance, product inquiries, or support needs, please contact ULTIMEA customer service. They offer pre-sale consultation and 7/24 service.

You can find contact information on the official ULTIMEA website or through the ULTIMEA app.

Visit the ULTIMEA Store on Amazon:[ULTIMEA Amazon Store](#)