



Manuals.plus /

- › GMWD /
- › GMWD Leg Extension and Curl Machine User Manual

GMWD LE03

GMWD Leg Extension and Curl Machine User Manual

Model: LE03 | Brand: GMWD

PRODUCT OVERVIEW

The GMWD LE03 Leg Extension and Curl Machine is a versatile 4-in-1 fitness equipment designed for comprehensive lower-body workouts in a home gym setting. This machine allows for seamless transitions between leg extension, lying leg curl, standing leg curl, and single leg extension exercises. Its robust construction and adjustable features provide a tailored and effective training experience.



Figure 1: GMWD LE03 Leg Extension and Curl Machine, showcasing its compact design and red/black color scheme.

SAFETY INFORMATION

Before operating the GMWD LE03 machine, please read and understand all safety instructions. Failure to do so may result in injury.

- Consult with a healthcare professional before starting any new exercise program.
- Ensure all bolts, nuts, and other connections are securely tightened before each use. Regularly inspect the machine for wear and tear.
- Keep children and pets away from the machine during operation.
- Use the machine on a stable, level surface. Ensure adequate space around the machine for safe operation.
- Do not exceed the maximum weight capacity of 350 lbs per side.
- Perform exercises with controlled movements. Avoid sudden jerking motions.
- If you experience pain or discomfort, stop exercising immediately.
- Wear appropriate athletic footwear and clothing.

ASSEMBLY AND SETUP

The GMWD LE03 machine requires assembly. A step-by-step video installation guide is available to assist with the setup process. It is recommended to have an additional person for assistance during assembly.

1. Unpack all components and verify against the parts list provided in the packaging.
2. Follow the detailed instructions in the assembly manual. Pay close attention to the correct placement of bolts and nuts.
3. Ensure all connections are tightened securely but do not overtighten until instructed.
4. Once assembled, perform a stability check to ensure the machine is firm and level.

SPACE-SAVING STRENGTH

MAXIMUM PERFORMANCE IN A MINIMAL FOOTPRINT

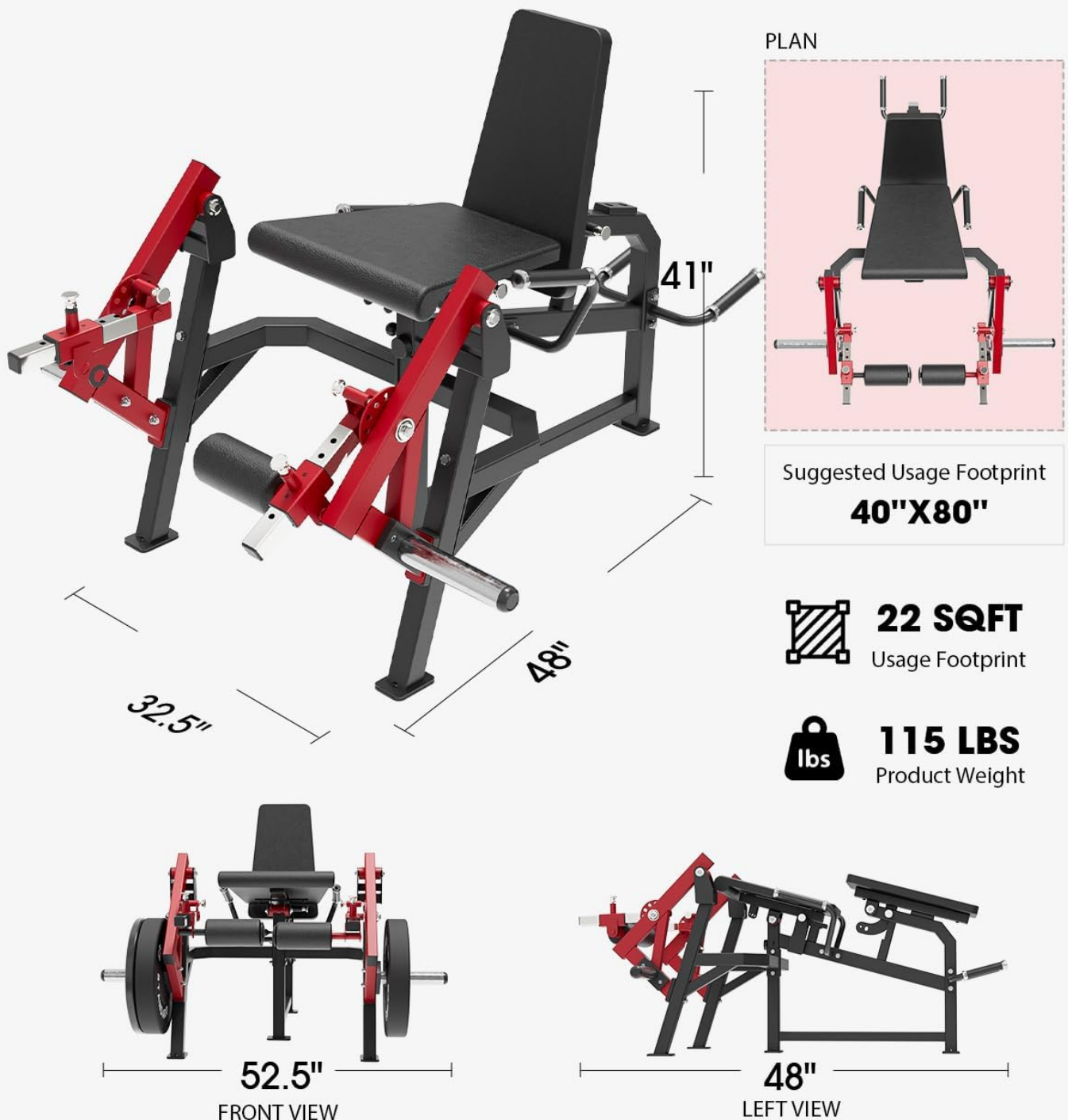

Figure 2: Machine dimensions and suggested usage footprint for setup planning.

OPERATING INSTRUCTIONS AND ADJUSTMENTS

The GMWD LE03 offers multiple exercise modes and extensive adjustability for a customized workout.

Exercise Modes:

- **Seated Leg Extension:** Targets quadriceps. Adjust the seat and leg roller to ensure proper alignment with your knee joint.
- **Lying Leg Curl:** Primarily targets hamstrings. Position yourself prone on the bench, aligning your knees with the pivot point.
- **Standing Leg Curl:** Engages hamstrings and glutes. Stand facing the machine, placing one leg on the roller.
- **Single Leg Extension/Curl:** Allows for unilateral training to correct muscle imbalances.

ONE MACHINE, THREE SOLUTIONS

UNILATERAL STRATEGIES FOR THE LEG TRAINING



SEATED LEG EXTENSION



STANDING LEG CURL



LYING LEG CURL

2 BACK CUSHION
POSITIONS

3 SEAT CUSHION
POSITIONS

4 LEG ROLLER
POSITIONS

3 TRAINING MOVES

Figure 3: Visual guide to the three primary exercise solutions: Seated Leg Extension, Standing Leg Curl, and Lying Leg Curl.



Figure 4: Demonstrations of Single Leg Extension and Seated Leg Extension exercises.



Figure 5: Demonstrations of Lying Leg Curl and Standing Single Leg Curl exercises.

Adjustments:

The LE03 features a Pop-Pin Adjustment System for quick and easy transitions.

- **Leg Roller Positions:** 4 ranges of movement for the leg rollers to accommodate different leg lengths and exercise types.
- **Seat Cushion Positions:** 3 adjustable seat cushion positions for optimal comfort and exercise mechanics.
- **Back Cushion Positions:** 2 adjustable back cushion positions to support various exercise angles.
- **Handles:** Two distinct handles are provided to match your workout preferences and provide stability during exercises.

SAFER PRONE LEG CURL

ENJOY THE INJURY - FREE TRAINING

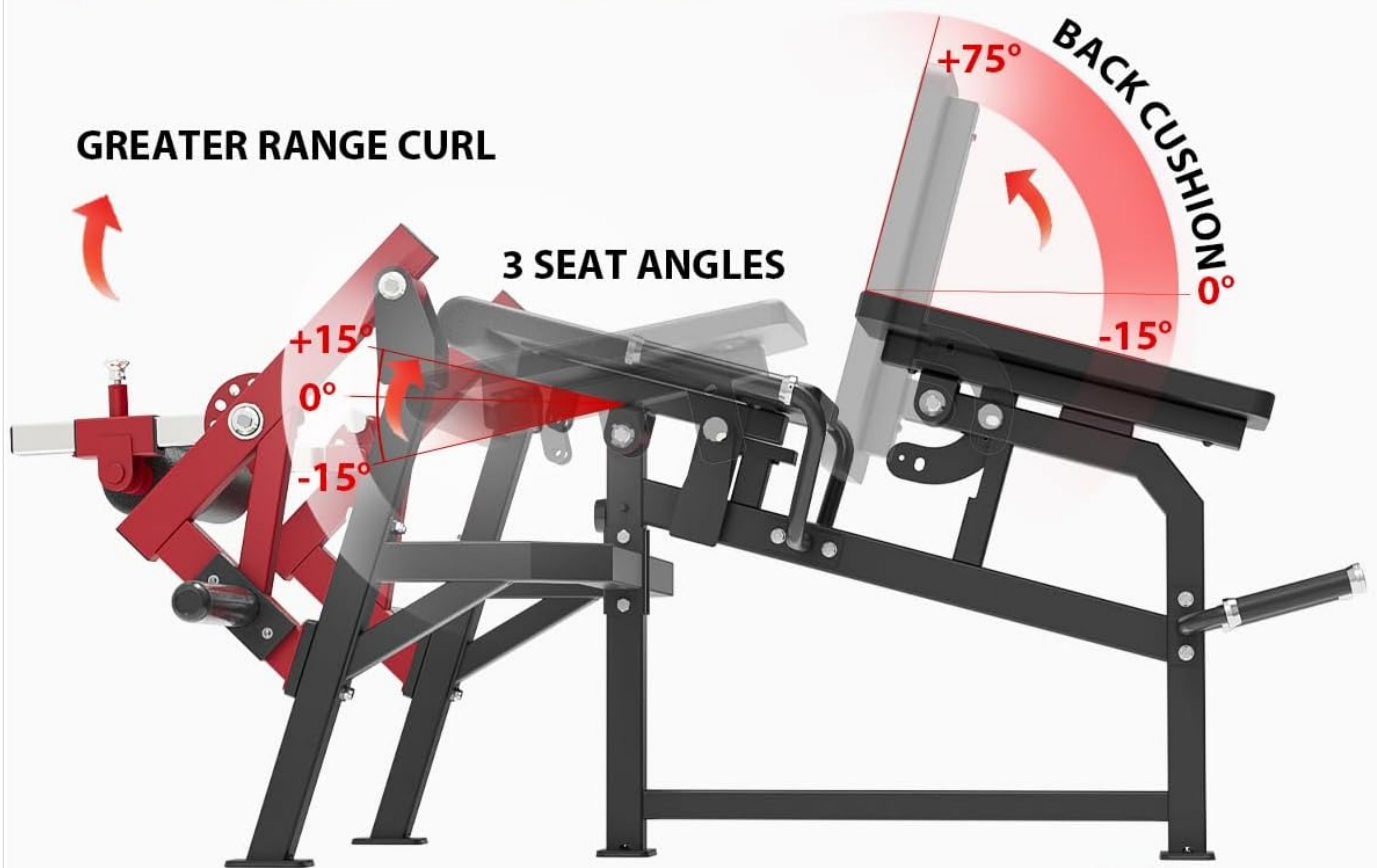

GREATER RANGE CURL

3 SEAT ANGLES

+75° BACK CUSHION
-15°

+15°
0°
-15°

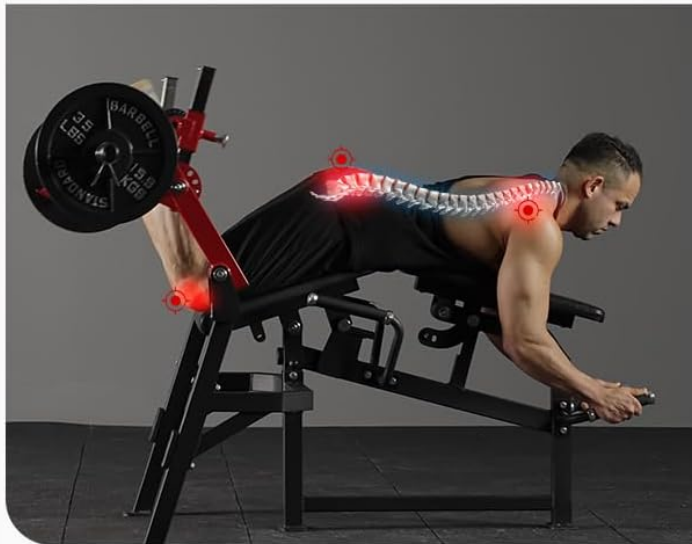

LYING LEG CURL

- Greater Range
- Ergonomic Curvature Design
- Isolates the Hamstrings
- Natural Movement

Figure 6: Illustration of back cushion and seat angles for prone leg curl, ensuring greater range and hamstring isolation.

PERFECT ALIGNMENT, EFFORTLESS MOTION

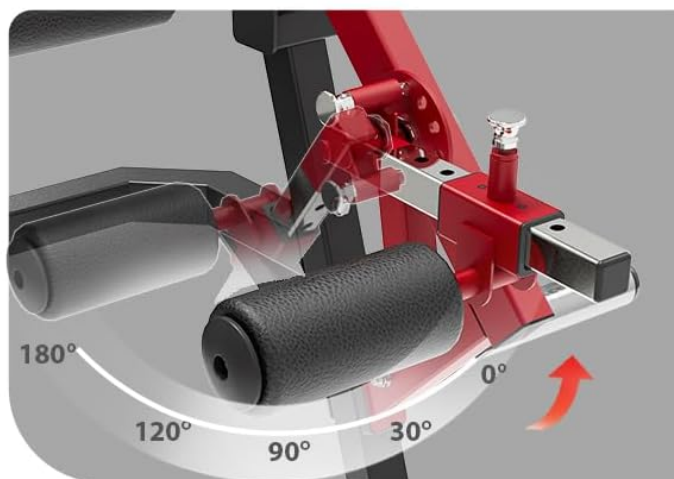

ANGLE ADJUSTMENT

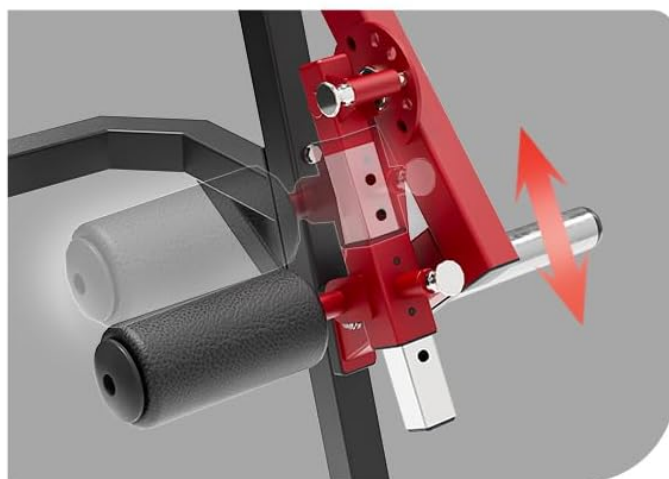

QUICK SNAP ON CHANGE

Figure 7: Details on angle adjustment and the quick snap-on change mechanism for leg rollers.



Figure 8: Close-up of the two handle options for varied grip and support during exercises.

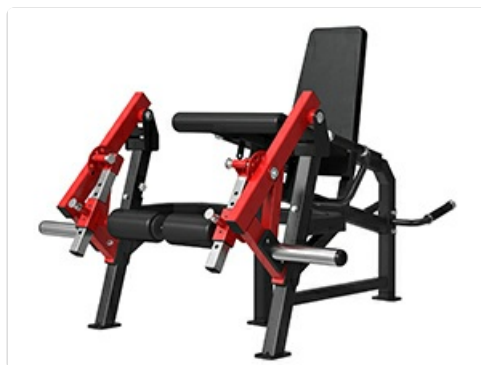
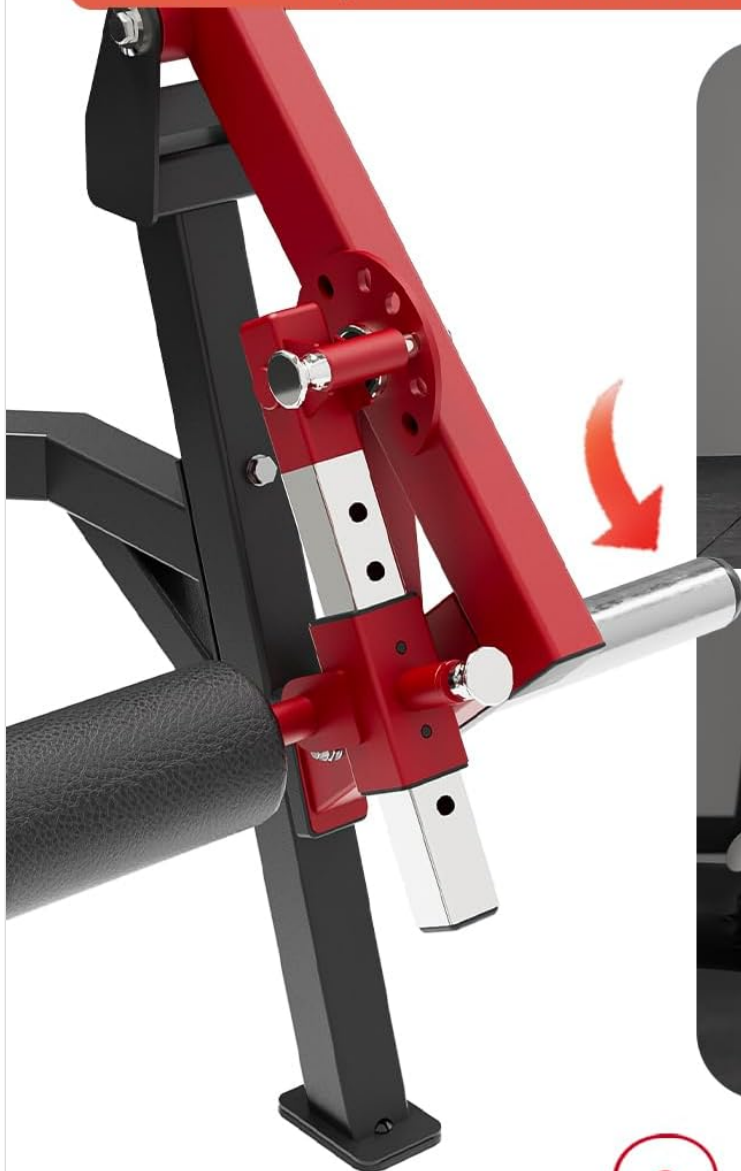

Figure 9: Illustration of the 6 ankle pad height choices to accommodate users of all heights.

PLATE-LOADED MEANS MORE POSSIBILITIES

ACCESSIBLE, FLEXIBLE & POWERFUL



What's Special?

- Imbalanced Weight Load
- 1:1 Force Ratio

350 LBS

MAX CAPACITY PER SIDE

Figure 10: The plate-loaded pin system, supporting up to 350 lbs per side for versatile resistance.

MAINTENANCE

Regular maintenance ensures the longevity and safe operation of your GMWD LE03 machine.

- **Cleaning:** Wipe down the machine with a damp cloth after each use to remove sweat and dust. Avoid abrasive cleaners.
- **Inspection:** Periodically check all nuts, bolts, and moving parts for tightness and wear. Tighten any loose fasteners.
- **Lubrication:** Apply a small amount of silicone-based lubricant to pivot points and moving parts as needed to ensure

smooth operation.

- **Storage:** Store the machine in a dry, temperate environment away from direct sunlight and extreme temperatures.

TROUBLESHOOTING

Problem	Possible Cause	Solution
Machine feels unstable or wobbly.	Loose fasteners; uneven floor.	Check and tighten all assembly bolts. Move machine to a level surface or use shims.
Squeaking or grinding noises during use.	Lack of lubrication; loose parts; foreign object.	Lubricate pivot points. Check and tighten all fasteners. Inspect for any obstructions.
Adjustments are difficult or stiff.	Dirt or debris in adjustment mechanism; lack of lubrication.	Clean adjustment pins and holes. Apply lubricant to moving parts of the adjustment system.

If you encounter issues not listed here or require further assistance, please contact GMWD customer support.

SPECIFICATIONS

Model: LE03

Brand: GMWD

Material: Heavy-duty 50x50 mm, 14-gauge steel tubing

Color: Red and Black

Product Dimensions (LxWxH): 48" x 32.5" x 41"

Item Weight: 115 Pounds

Maximum Weight Recommendation (Plate Loaded): Up to 350 lbs per side

Tension Level: 440 pounds (likely referring to overall structural integrity/load bearing)

Adjustments: 4 leg roller positions, 3 seat cushion positions, 2 back cushion positions

Handle Type: Fixed Handle

Strap Type: Linear bearing straps

WARRANTY AND SUPPORT

The GMWD LE03 Leg Extension and Curl Machine comes with a **1 Year Manufacturer Warranty**.

For any questions, concerns, or technical assistance, GMWD offers **24/7 customer support**. Please refer to the contact information provided with your purchase or visit the official GMWD website for support details.

For more information, you can visit the [GMWD Store on Amazon](#).