



Manuals.plus /

- › **AZZUNO** /
- › AZZUNO MIG-200L Multi-Process Welder Instruction Manual

## AZZUNO MIG-200L

# AZZUNO MIG-200L Multi-Process Welder Instruction Manual

Model: MIG-200L | Brand: AZZUNO

## 1. INTRODUCTION

The AZZUNO MIG-200L is an advanced 8-in-1 multi-process welding machine designed for versatility and ease of use. It supports a wide range of welding modes including Flux Core MIG, Gas MIG, Gas MAG, Aluminum MIG, Spot MIG, Lift TIG, and Stick Welding. This welder operates on both 110V and 220V power inputs and features a large LED display for clear operation. This manual provides essential information for safe and effective use of your AZZUNO MIG-200L welder.



Figure 1: AZZUNO MIG-200L Multi-Process Welder and included accessories.

## 2. PACKING LIST

Please check the contents of your package against the list below:

- AZZUNO MIG-200L Welder Machine x1
- 15AK MIG Torch x1
- Ground Clamp x1
- Electrode Holder x1
- 110V~220V Adapter x1
- Brush & Hammer x1
- Gas hose x1
- Hose Band x2
- Drive Roller x2
- Contact Tip x4
- Teflon Liner x1

- User Manual x1

	=	$U_1 = 110V\sim$			$U_1 = 220V\sim$			
		40A / 16V - 120A / 20V			40A / 16V - 200A / 24V (φ0.9)			
S	$U_0 = 65V$	X	50%	80%	100%	50%	60%	100%
		I <sub>2</sub>	120A	110A	80A	200A	180A	140A
		U <sub>2</sub>	20V	19.5V	18V	24V	23V	21V
DC ~ 1-50/60Hz		$U_1 = 110V$	$I_{1max} = 41.5A$			$I_{1off} = 29.3A$		
		$U_1 = 220V$	$I_{1max} = 45.3A$			$I_{1off} = 32A$		

## PANEL INTRODUCTION



Figure 2: All components included in the AZZUNO MIG-200L package.

### 3. SPECIFICATIONS

Feature	Detail
Model	MIG-200L
Input Voltage	110V/220V
Max Amperage	200A
Welding Modes	Flux Core MIG, Gas MIG, Gas MAG, Aluminum MIG, Spot MIG, Lift TIG, Stick Welding, Spool Gun Compatible
Wire Spool Compatibility	1 lb to 10 lbs
Wire Diameters Supported	.023"/.030"/.035"/.040" solid wire, .023"/.030"/.035"/.040" flux core wire, .035"/.040"/.047" ER5356 aluminum wire, .040" CuSi wire
Dimensions (L x W x H)	17.7" x 9.6" x 12.4"
Weight	23 lbs

### 4. SETUP GUIDE

Follow these steps for initial setup of your AZZUNO MIG-200L welder:

#### 4.1 Power Connection

The MIG-200L supports both 110V and 220V power inputs. Use the provided adapter if converting from 110V to 220V. Ensure the power source matches the welder's requirements and is properly grounded.

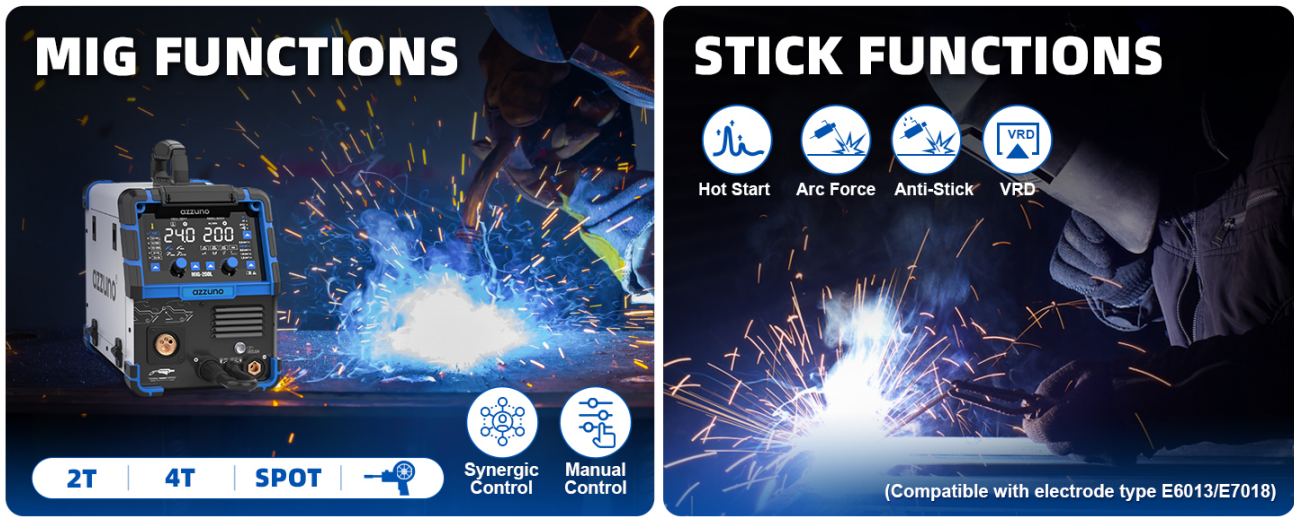

Figure 3: Overview of the welder's control panel and connection points.

## 4.2 Wire Spool Installation

Open the side panel of the welder to access the wire feed mechanism. Install the desired wire spool (1lb to 10lbs) onto the spindle. Ensure the wire is correctly threaded through the drive roller and into the torch liner. The welder supports various wire types and diameters as listed in the specifications.

# APPLY TO 1LB-10LBS WIRE

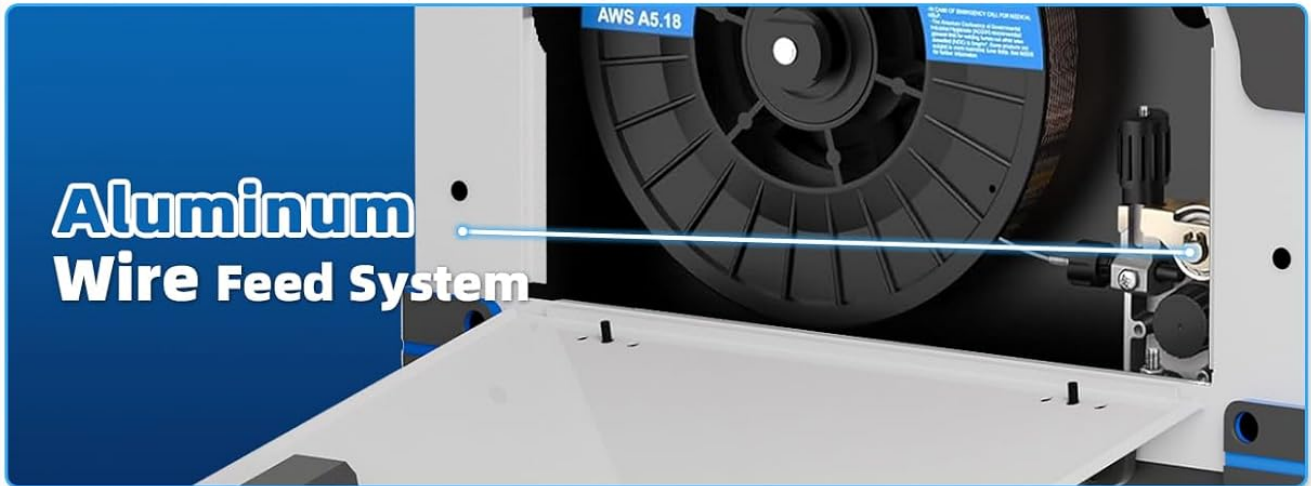

Figure 4: Proper installation of welding wire spools.



Figure 5: Select the correct drive roller groove (K-groove for Flux, V-groove for Solid, U-groove for Aluminum) for your wire type.

### 4.3 Torch and Clamp Connection

Connect the MIG torch and ground clamp to the appropriate terminals on the front panel of the welder. Ensure connections are secure to prevent arcing and ensure proper current flow.

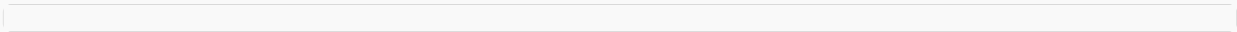

Figure 6: Connection diagrams for different welding processes.

## 5. OPERATING INSTRUCTIONS

The AZZUNO MIG-200L features a user-friendly large LED display for easy mode selection and parameter adjustment.

# USER-FRIENDLY LARGE LED PANEL

1

Stick Welding  
Functions

2

MIG Welding  
Functions

3

ST/4T/SPOT/  
SPOOL GUN



Figure 7: User-friendly large LED control panel.

## 5.1 Mode Selection

Use the 'Welding Mode Choose Button' on the control panel to select your desired welding process (Flux Core MIG, Gas MIG, Gas MAG, Aluminum MIG, Spot MIG, Lift TIG, Stick Welding). The SYNERGIC mode automatically adjusts settings for optimal performance, while 2T and 4T modes cater to manual and continuous welding respectively. The Spot function is ideal for precise, short welds.

# 8-IN-1 MULTIPROCESS

## Welding Machine



Figure 8: The 8-in-1 multi-process capabilities of the welder.

### 5.2 Parameter Adjustment

Adjust Voltage and Current using the respective knobs. The 'Wire Diameter Select Button' allows you to choose the correct wire diameter for your application. For Aluminum MIG welding, you can either replace the liner with the included Teflon conduit or use a spool gun (sold separately).



Figure 9: Two methods for Aluminum MIG welding.

### 5.3 Welding Techniques

Familiarize yourself with the specific techniques for each welding mode. The welder offers features like Hot Start, Arc Force, and Anti-Stick for Stick welding, and Inductance, Slow Wire Feeding, Pre-flow, and Spot Time for MIG functions to optimize your welding experience.

# MIG FUNCTIONS



Inductance



Slow Wire Feeding



Pre-flow



Spot Time

# STICK FUNCTIONS



Hot Start



Arc Force



Anti-Stick



VRD

Figure 10: Key functions for MIG and Stick welding modes.

## 6. MAINTENANCE

Regular maintenance ensures the longevity and optimal performance of your AZZUNO MIG-200L welder.

### 6.1 Cleaning

- Regularly clean the welding torch, especially the contact tip and nozzle, to prevent spatter buildup.

- Use the provided brush and hammer to remove slag and spatter from your workpieces.
- Keep the ventilation openings of the welder clear of dust and debris to ensure proper cooling.

## 6.2 Storage

Store the welder in a dry, clean environment away from direct sunlight, moisture, and extreme temperatures. Disconnect all cables and store them neatly to prevent damage.

## 7. TROUBLESHOOTING

If you encounter issues with your welder, refer to the following common troubleshooting tips:

- **No Power:** Ensure the power cable is securely connected and the power switch is ON. Check the circuit breaker.
- **No Arc:** Verify that the ground clamp is securely attached to the workpiece and that the welding torch is properly connected. Ensure the wire feed is functioning correctly and the contact tip is not clogged.
- **Poor Weld Quality:** Adjust voltage and wire feed speed according to the material thickness and welding mode. Ensure proper gas flow (for Gas MIG/MAG) or correct flux core wire is used. Clean the workpiece thoroughly before welding.
- **Overheating:** If the welder stops operating due to overheating, allow it to cool down. Ensure adequate ventilation around the machine.

For more detailed troubleshooting or issues not listed here, please contact AZZUNO customer support.

## 8. WARRANTY AND SUPPORT

For warranty information, technical support, or to purchase replacement parts and accessories, please refer to the official AZZUNO website or contact their customer service directly. Keep your purchase receipt as proof of purchase for warranty claims.

Visit the AZZUNO Store for more products and information.