



Manuals.plus /

› YELUFT /

› YELUFT ESP32 LoRa V3 Development Board with GT-U7 GPS Module User Manual

YELUFT ESP32 LoRa V3

YELUFT ESP32 LoRa V3 Development Board with GT-U7 GPS Module

USER MANUAL

1. Introduction

This manual provides detailed instructions for the setup, operation, and maintenance of the YELUFT ESP32 LoRa V3 Development Board integrated with a GT-U7 GPS Module. This device combines WiFi, Bluetooth, and LoRa communication capabilities with precise GPS functionality, making it suitable for various IoT applications, including Meshtastic networks.

Key features include:

- **Enhanced GPS and RTC:** The GT-U7 GPS module provides accurate positioning and Real-Time Clock (RTC) functionality, reducing reliance on external time sources.
- **Versatile Communication:** Integrated WiFi, LoRa (SX1262), and Bluetooth for flexible connectivity options.
- **Power Management:** Features a SH1.25-2 battery interface and integrated lithium battery management system, with Type-C power input offering ESD and short-circuit protection.
- **Onboard OLED Display:** A 0.96-inch 128x64 dot matrix OLED display for debugging information, battery status, and user interaction.

2. Package Contents

Verify that all items listed below are included in your package:

- 1 x ESP32 LoRa V3 Development Board
- 1 x GT-U7 GPS Module
- 1 x LoRa Antenna (915MHz)
- 1 x GPS Antenna

- Pin Headers (various sizes for assembly)
- 1 x Power Cord (for battery connection)

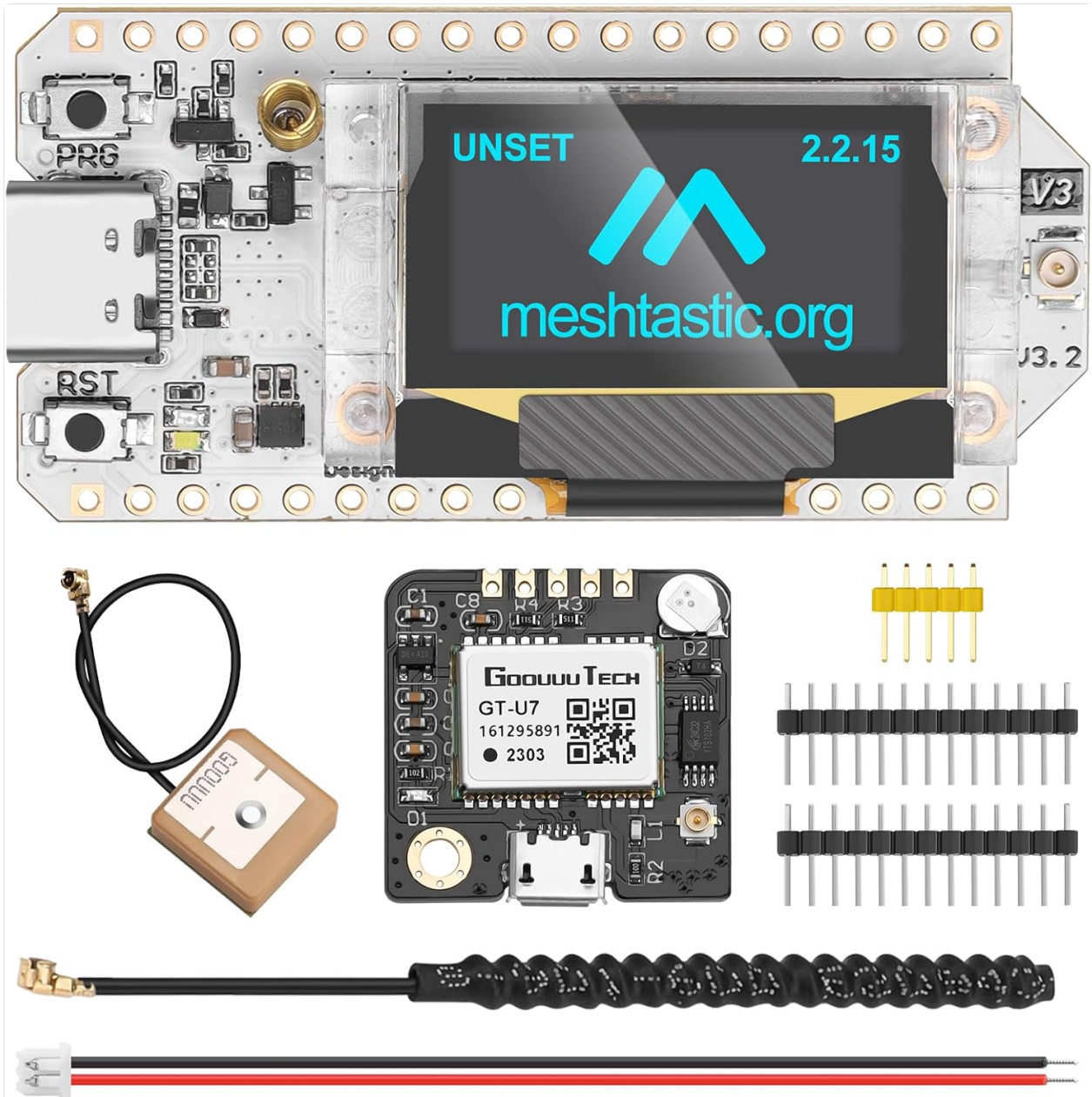

Image 2.1: Overview of the YELUFT ESP32 LoRa V3 Development Board and included components.

3. Product Overview

3.1 ESP32 LoRa V3 Development Board

The ESP32 LoRa V3 board is a powerful development platform featuring an ESP32 microcontroller, LoRa transceiver, WiFi, Bluetooth, and an integrated 0.96-inch OLED display. It is designed for low-power IoT applications requiring long-range communication.

ESP32 LoRa V3

ESP32 Development Board with 0.96-inch OLED Display

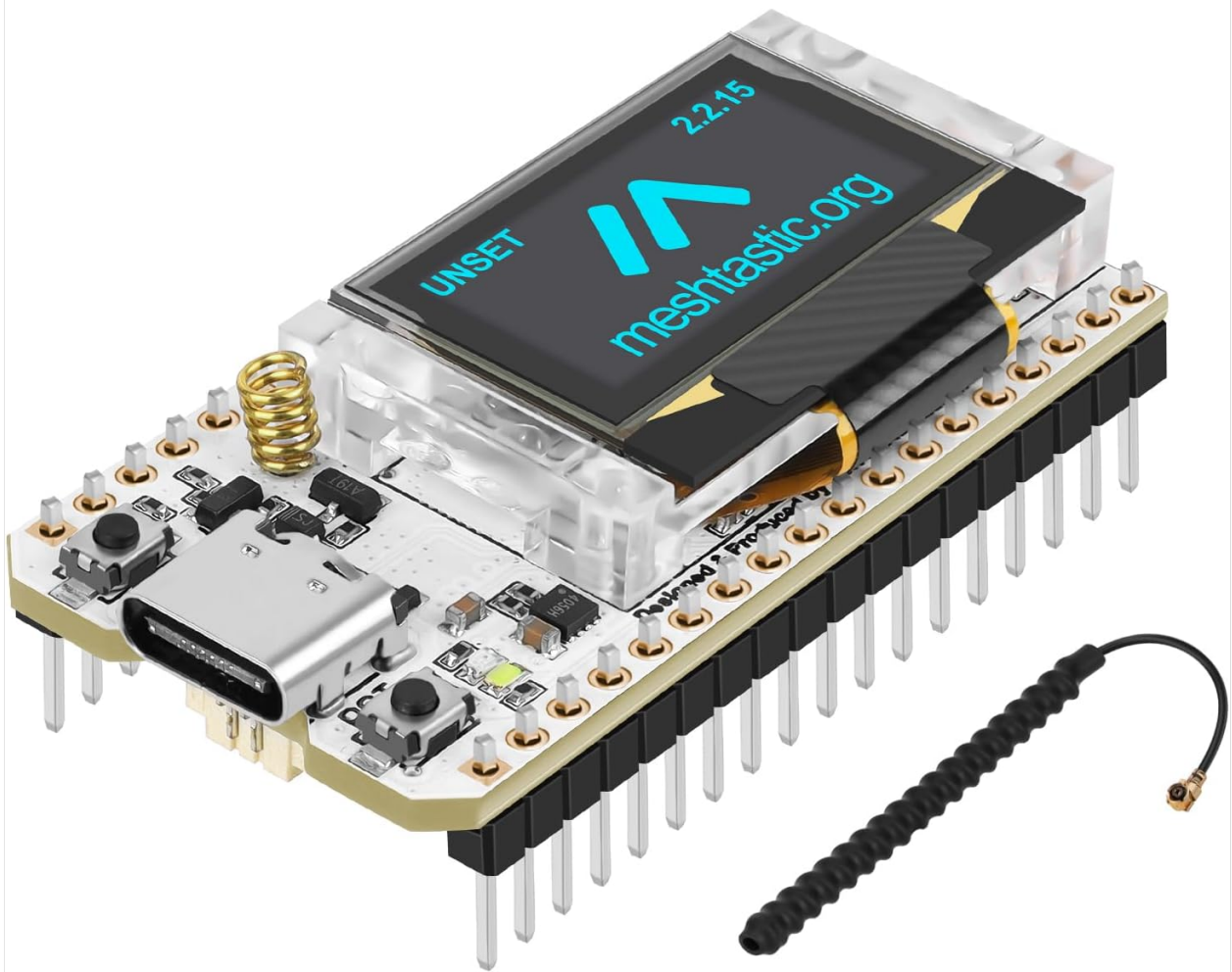

Note: WiFi LoRa 32 comes unassembled, soldering is required

Image 3.1: The ESP32 LoRa V3 Development Board.

3.2 GT-U7 GPS Module

The GT-U7 GPS module provides accurate satellite positioning data. It is compatible with the UBLOX 7th generation chip and software, similar to NEO-6M modules. This module enhances the development board's capabilities for location-aware applications.

GT-U7 GPS Module

GT-U7 main module GPS module using the original UBLOX 7th generation chip, software is compatible with NEO-6M

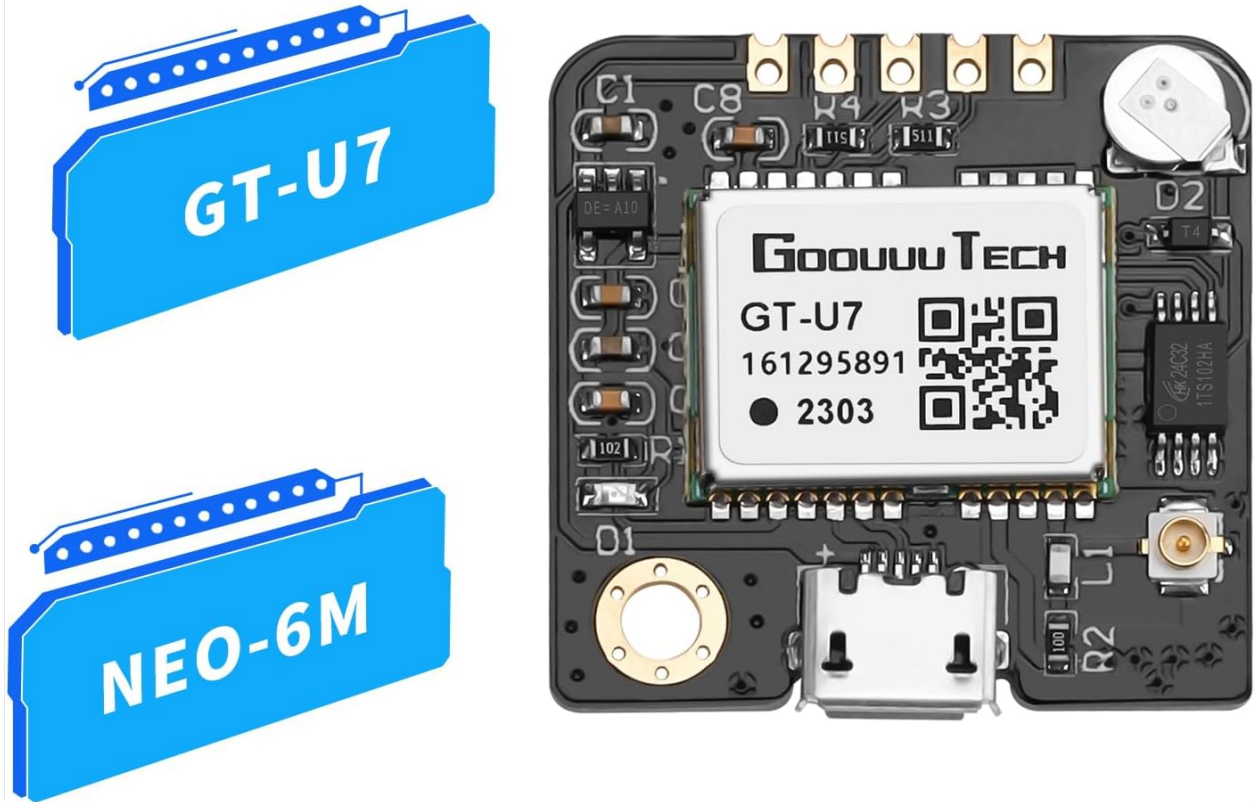

Image 3.2: The GT-U7 GPS Module.

4. Specifications

Feature	Specification
Brand	YELUFT
Model Name	ESP32 LoRa V3
Connectivity Technology	WiFi, LoRa, Bluetooth
Processor Brand	Espressif
Operating System	Linux (compatible)
RAM	DDR3
Item Weight	1.13 ounces
Package Dimensions	4.21 x 2.56 x 1.22 inches

5. Setup

5.1 Assembly and Soldering

The ESP32 LoRa V3 board and GT-U7 GPS module come unassembled. Soldering is required to connect the pin headers and the GPS module to the main board. Ensure proper soldering techniques are used to avoid damage to components.

5.2 Power Supply

The development board can be powered via the SH1.25-2 battery interface or the Type-C USB port. The Type-C interface includes ESD protection, short-circuit protection, and RF shielding. When using a battery, ensure it is compatible with the integrated lithium battery management system.

5.3 Antenna Connection

Connect the provided LoRa antenna to the IPEX (U.FL) interface on the ESP32 LoRa V3 board. Connect the GPS antenna to the GT-U7 GPS module.

5.4 Wiring the GT-U7 GPS Module

To integrate the GT-U7 GPS module with the ESP32 LoRa V3 board, follow one of the wiring methods below. The GT-U7 GPS module may increase power requirements, so consider implementing power management.

5.4.1 Through-Hole Wiring Method (with NPN MOSFET)

An NPN MOSFET can be used as a switch for the GPS module's ground (GND) connection, allowing for firmware-controlled power management. This method helps conserve battery life.

- **Gate:** Connect to a GPIO pin on the ESP32 (e.g., PIN_GPS_EN, which can be any pin you define, such as GPIO46).
- **Drain:** Connect to the GPS module's GND.
- **Source:** Connect to the LoRa Board's GND.

Wiring Method - Through-Hole

NPN MOSFET acts as a switch for the GND
Connections as follows:
Gate -PIN_GPS_EN
Drain-GPS GND
Source -Lora Board GND

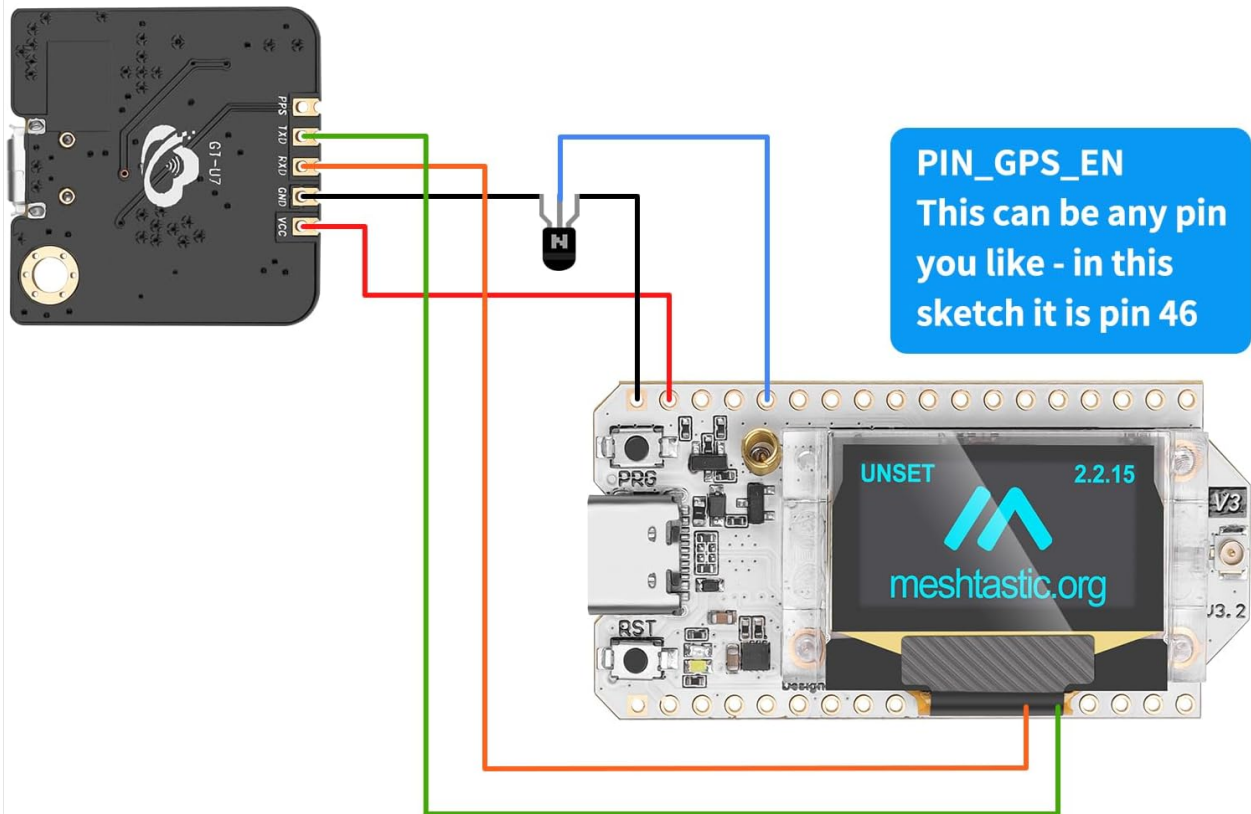

Image 5.1: Through-Hole Wiring Method with NPN MOSFET.

5.4.2 Surface Mount MOSFET Wiring Method

Alternatively, a surface mount MOSFET can be integrated directly onto the board for a more compact solution. This also enables firmware-controlled power management for the GPS module.

Wiring Method - Surface Mount MOSFET

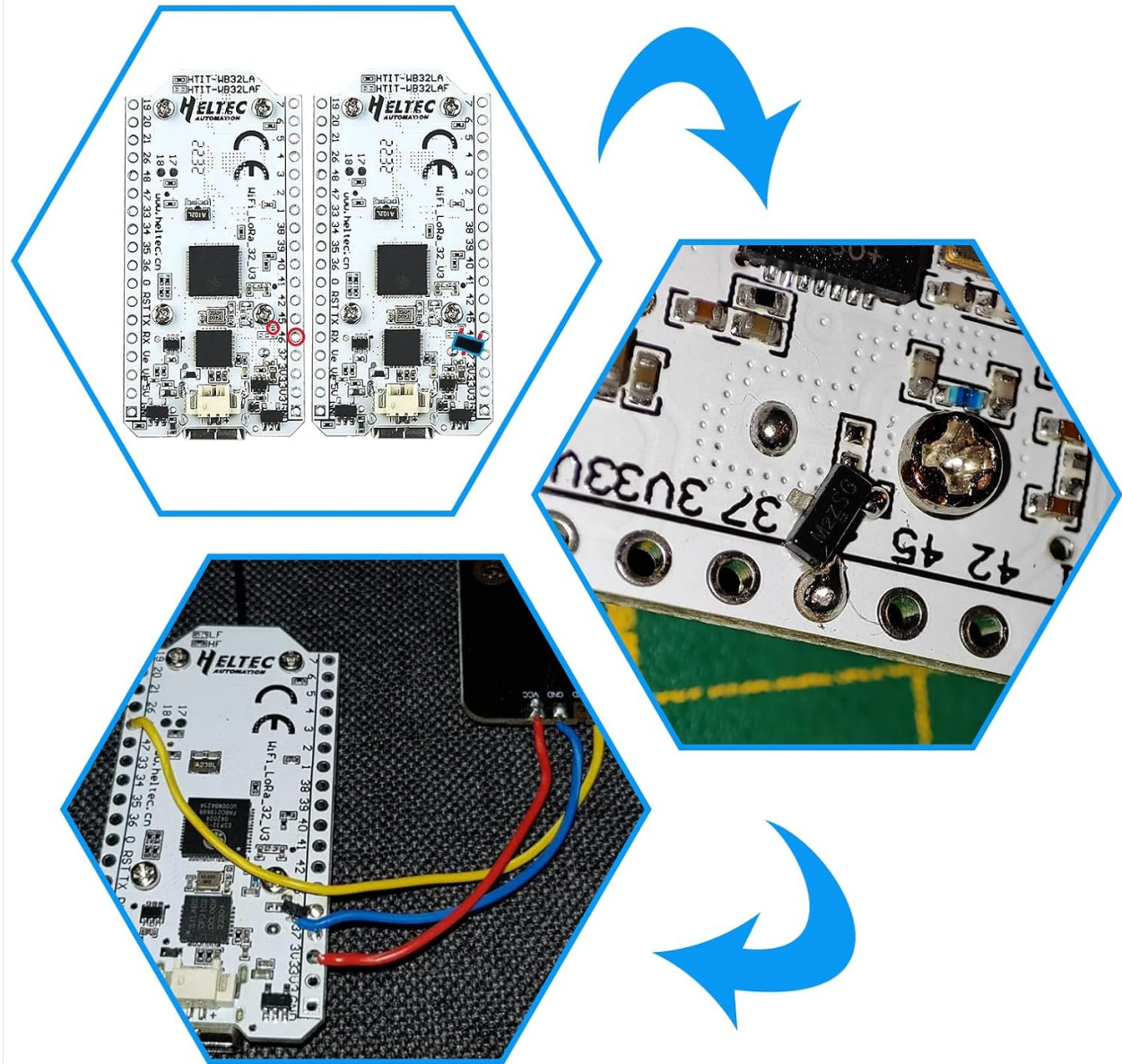

Image 5.2: Surface Mount MOSFET Wiring Method.

6. Pin Maps

6.1 ESP32 LoRa V3 Pin Map

Refer to the following diagram for the pin assignments of the ESP32 LoRa V3 Development Board. Understanding the pinout is crucial for connecting external sensors and peripherals.

Pin Map - ESP32 LoRa V3

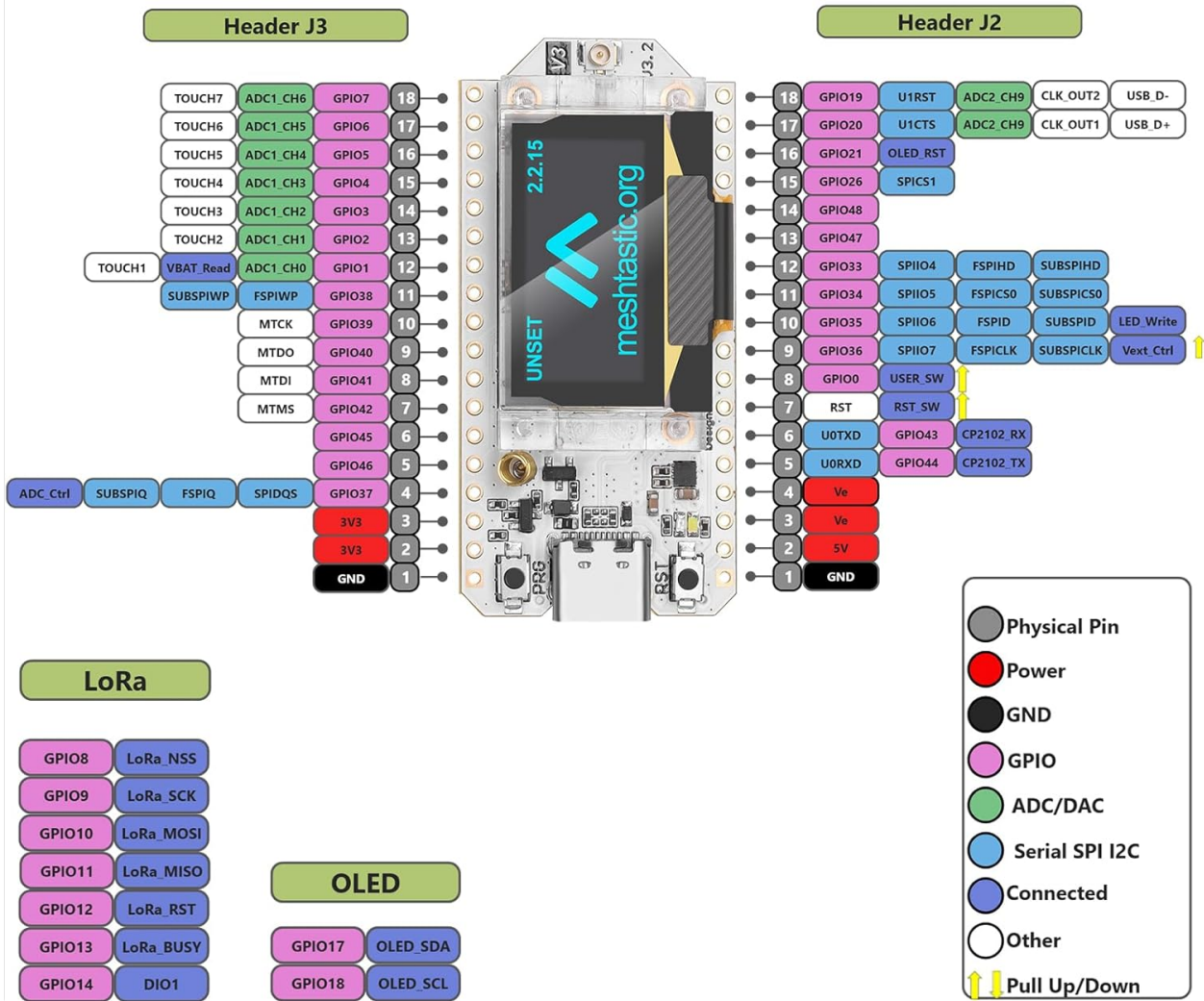

Image 6.1: ESP32 LoRa V3 Pin Map.

6.2 GT-U7 GPS Module Pin Map

The GT-U7 GPS module has dedicated pins for power, ground, and serial communication (TX/RX), as well as a Pulse Per Second (PPS) output pin.

Pin Map - GT-U7 GPS Module

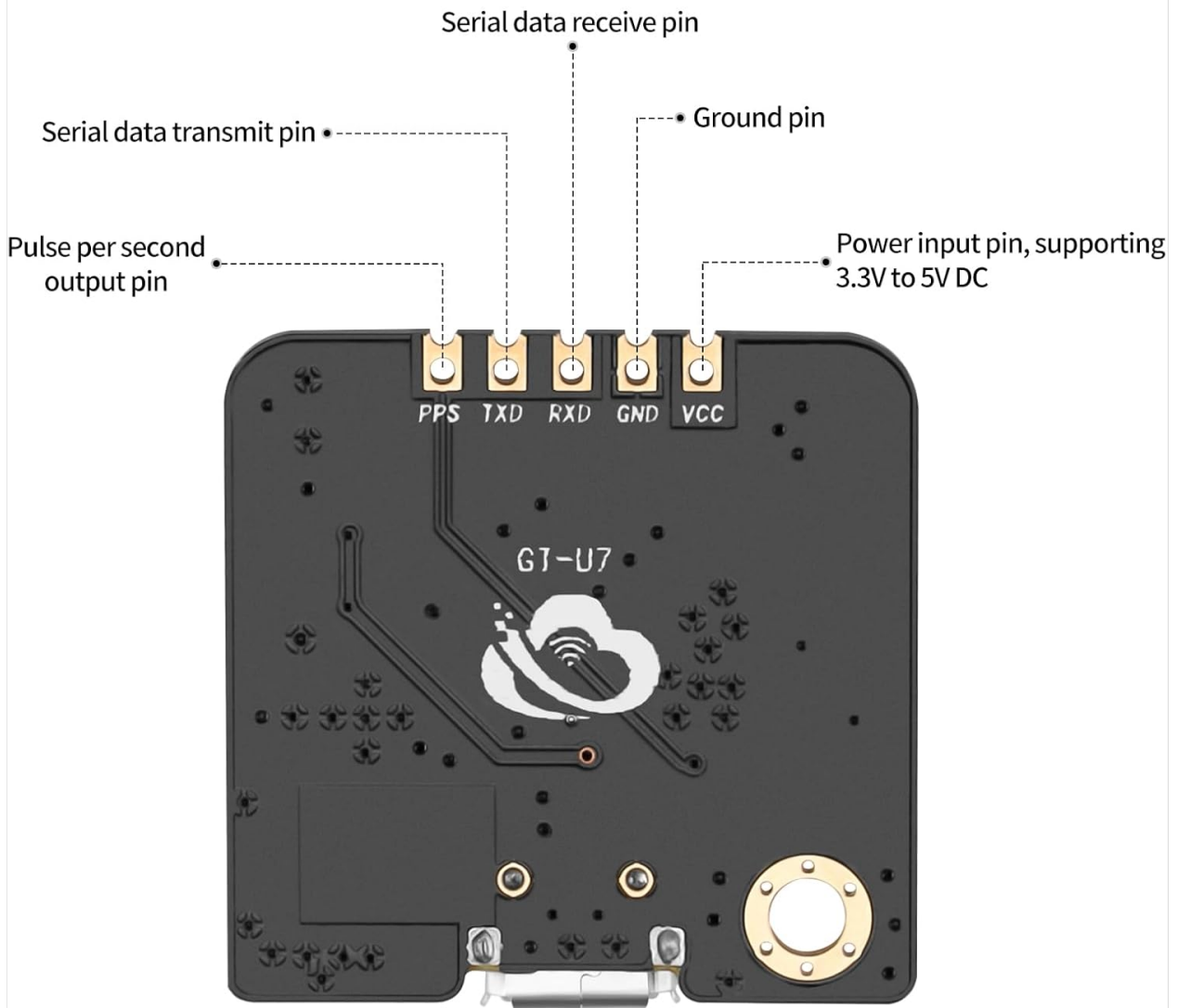

Image 6.2: GT-U7 GPS Module Pin Map.

7. Operating Instructions

Once assembled and powered, the ESP32 LoRa V3 board can be programmed using development environments like Arduino IDE or PlatformIO. Firmware such as Meshtastic can be uploaded to enable mesh networking capabilities.

- **Firmware Upload:** Connect the board to your computer via the Type-C USB port. Use the appropriate drivers (e.g., CP2102) and development environment to upload your desired firmware.
- **OLED Display:** The onboard 0.96-inch OLED display can be used to show real-time data, debugging messages, and battery levels, depending on the firmware implemented.
- **GPS Functionality:** The GT-U7 GPS module provides location data and RTC. Ensure the GPS antenna has a clear view of the sky for optimal signal reception.
- **LoRa Communication:** The SX1262 LoRa transceiver enables long-range, low-power communication. Configure LoRa parameters (frequency, spreading factor, bandwidth) within your firmware.
- **WiFi and Bluetooth:** Utilize the integrated WiFi and Bluetooth for local network connectivity, configuration, or short-range communication as required by your application.

8. Power Management

The GT-U7 GPS module, while providing essential functionality, can increase the overall power consumption of the node. To optimize battery life, especially in portable applications, it is recommended to implement power management strategies:

- **MOSFET Control:** As described in Section 5.4, using a switch or N-channel MOSFET allows the firmware to control when the GPS module is powered on or off. This enables the GPS to be activated only when location data is needed, significantly saving battery life compared to continuous operation or soft sleep options.
- **Deep Sleep Modes:** The ESP32 supports various deep sleep modes. Combine these with GPS power cycling to achieve maximum efficiency.

9. Maintenance

To ensure the longevity and optimal performance of your development board:

- **Handle with Care:** Avoid dropping the board or exposing it to excessive physical stress.
- **Keep Dry:** Protect the board from moisture and humidity.
- **Cleanliness:** Keep the board free from dust and debris. Use compressed air or a soft brush for cleaning.
- **Proper Storage:** Store the board in an anti-static bag when not in use.

10. Troubleshooting

- **OLED Display Not Working:**

If the OLED display does not show any output after uploading firmware, verify the I2C connections (SDA, SCL) and ensure the correct display driver is initialized in your code. Some firmware versions or development environments may require specific configurations for the OLED.

- **GPS Module Not Acquiring Fix:**

Ensure the GPS antenna is properly connected and has a clear, unobstructed view of the sky. Initial GPS fix can take several minutes. Check wiring to the GT-U7 module and verify that the module is receiving power.

- **LoRa Communication Issues:**

Check antenna connection. Verify LoRa frequency, spreading factor, and bandwidth settings in your firmware match those of the receiving device. Ensure both devices are within range and not experiencing excessive interference.

- **Board Not Powering On:**

Check Type-C USB cable and power source. If using a battery, ensure it is charged and correctly connected to the SH1.25-2 interface.

11. Warranty and Support

For warranty information and technical support, please refer to the official YELUFT brand store or contact YELUFT customer service directly. Keep your purchase receipt for warranty claims.

Visit the YELUFT Store for more information and resources.

