



Manuals.plus /

› **Blindsmart** /

› Blindsmart Smart Home Energy Monitor (WiFi Version) Instruction Manual

Blindsmart SDM02T-TW-120A/IEC-ZM

Blindsmart Smart Home Energy Monitor (WiFi Version) Instruction Manual

Model: SDM02T-TW-120A/IEC-ZM

Brand: Blindsmart

1. INTRODUCTION

The Blindsmart Smart Home Energy Monitor provides accurate, real-time tracking of your home's electricity usage. This device is designed to help you understand and manage your energy consumption, potentially leading to reduced electricity costs. It supports single-phase 3-wire systems and features bi-directional power monitoring, making it suitable for homes with solar or battery storage systems.

Key features include:

- **Accurate Energy Monitoring:** Delivers precise tracking of voltage, current, power, and total energy consumption.
- **Bi-Directional Power Monitoring:** Measures both household consumption and power export to the grid with Class 1 accuracy.
- **Smart App & Home Automation Integration:** Compatible with the Smart Life app for real-time data analysis, alerts, and customizable automation scenes.
- **Optimized for Home Energy Management:** Supports Dynamic Load Balancing (DLB) and zero grid export mode for maximum energy efficiency.

2. PARTS DESCRIPTION

Familiarize yourself with the components of your Smart Home Energy Monitor:

Parts Description

Make sure the red wire of the CT gets connected to "+" and black wire to "-" at the connector.

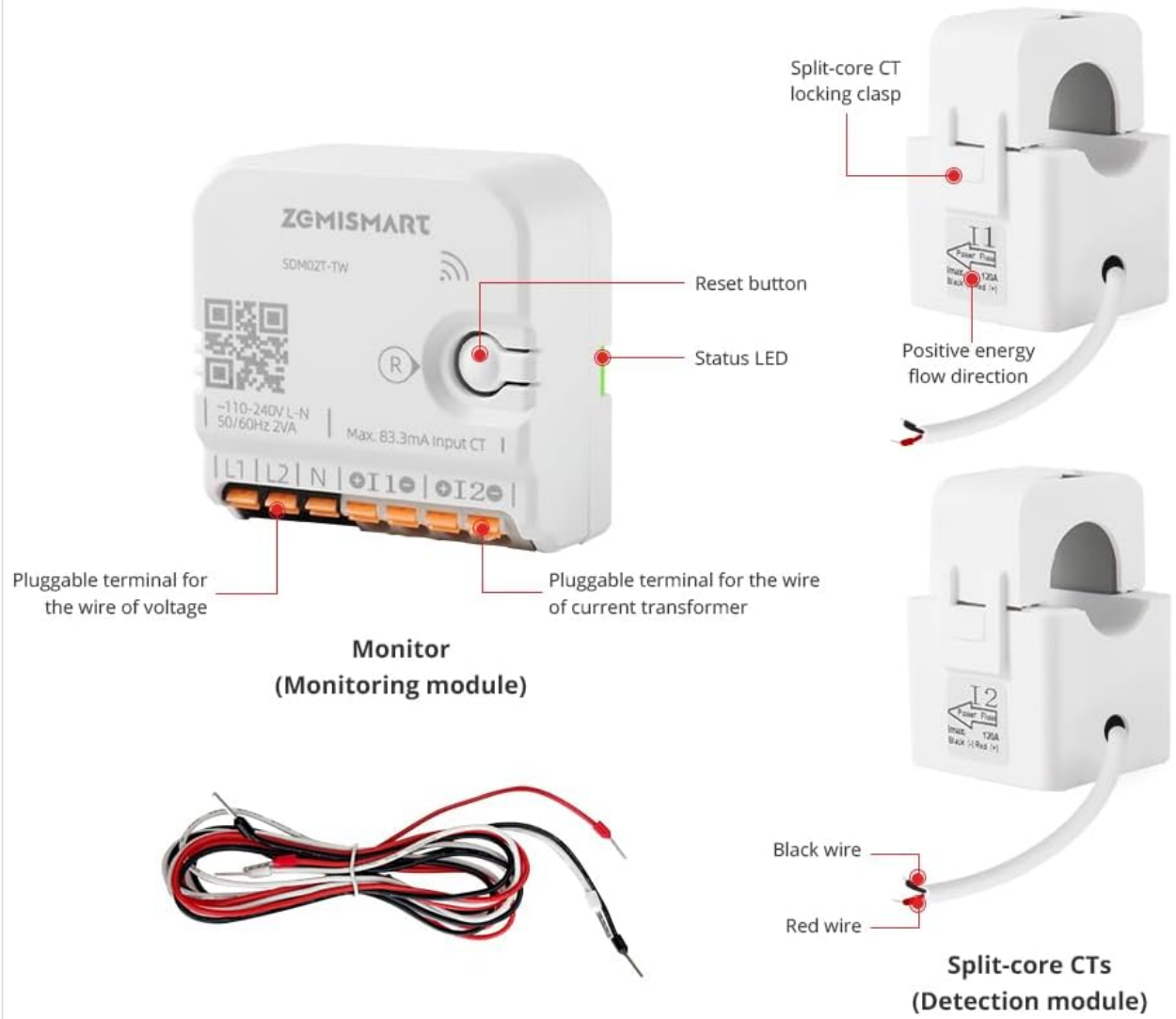

Image 2.1: Components of the Blindsmart Smart Home Energy Monitor. This image displays the main monitoring module, two split-core current transformers (CTs) with attached wires, and separate voltage take-off wires. The monitoring module features a reset button, status LED, and pluggable terminals for both voltage and current transformer wires. The split-core CTs are labeled I1 and I2, indicating positive energy flow direction, and show black and red wires for connection.

- **Monitor (Monitoring Module):** The central unit that processes energy data. It includes a reset button, status LED, and terminals for connections.
- **Split-core CTs (Detection Module):** Two 120A current transformers that clamp around the main power lines to measure current flow. They are labeled I1 and I2, with arrows indicating the positive energy flow direction.
- **Voltage Take-off Wires:** Wires used to connect the module to the electrical panel for voltage measurement.

3. SETUP AND INSTALLATION

Important Safety Information: Installation of the SDM02 requires removal of all power. Be sure to provide an alternate light source before beginning the installation procedures. Do not begin the installation procedures until all power is completely removed from the equipment, including any alternate power sources. **The SDM02 must be installed and maintained by qualified professionals.**

3.1 Wiring Diagram

The device is suitable for use in UL single-phase (split-phase) three-wire systems and UL/IEC single-phase systems up to two branch circuits.



Image 3.1: This diagram illustrates the wiring for the Blinds smart Smart Home Energy Monitor. It shows two configurations: a UL Single-phase (split-phase) three-wire system and a UL/IEC 1P+N system up to 2 branch circuits. The monitor connects to L1, L2, and Neutral, with CTs clamping around the main lines. A caution note emphasizes that SDM02 can only be installed upstream if associated with a contactor, frequency converter, or motor starters.

3.2 Connecting the SDM02 Module

Follow these steps to connect the module:

1. **Insert Voltage Take-off Wires:** Insert the voltage take-off wires (black, red, white) into the pluggable terminal of the monitoring module. Ensure the black wire connects to 'L1', red to 'L2', and white to 'N'.
2. **Insert Split-core CT Wires:** Insert the wires from the split-core CTs (I1 and I2) into their respective pluggable terminals on the monitoring module. Ensure the red wire of the CT connects to '+' and the black wire to '-' at the connector.
3. **Connect to Electrical Panel:** Connect the black and red voltage take-off wires to an empty 240V breaker. Connect the white wire to the neutral bus bar.
4. **Clamp CTs:** Clamp the I1 and I2 split-core CTs around the main power lines (L1 and L2) coming into your circuit breaker box. Ensure the arrows on the CTs indicate the direction of power flow.

Your browser does not support the video tag.

Video 3.2: This video provides a step-by-step guide on how to connect the Blinds smart Smart Home Energy Monitor. It demonstrates inserting the voltage take-off wires and the split-core CT wires into the module's terminals, and then shows the process of clamping the CTs onto the main power lines within an electrical panel. It also covers connecting the voltage wires to the appropriate breaker and neutral bus bar.

4. OPERATING THE ENERGY MONITOR

The Blinds smart Smart Home Energy Monitor operates through a dedicated mobile application, allowing you to monitor and manage your energy usage remotely.

4.1 App Control and Real-time Monitoring

After successful installation and pairing with the Smart Life app, you can access real-time electrical data.

Application Illustration

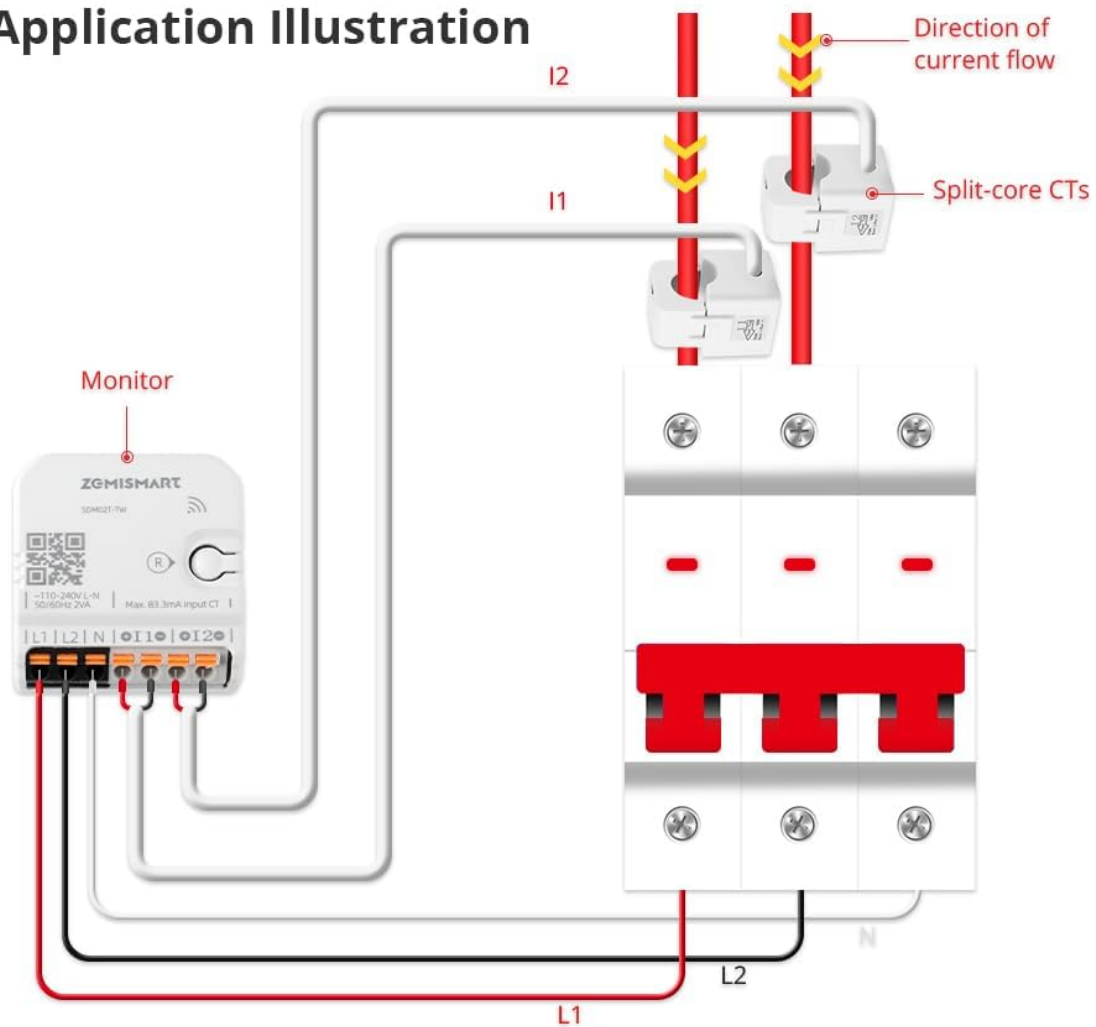

*SDM02 can only be installed upstream if associated with a contactor, frequency converter or motor starters.

Image 4.1: A screenshot of the Smart Life mobile application interface, showing real-time electrical data from the Blindsmart Smart Home Energy Monitor. The display includes current (A), active power (kW), and voltage (V) readings for both L1 and L2 lines, along with total forward energy, total reverse active energy, daily energy consumption chart, overall power factor, and frequency.

- **Real-time Data:** View current, active power, and voltage for both L1 and L2 phases.
- **Energy Consumption Statistics:** Track total forward and reverse active energy, and view daily, monthly, or yearly consumption charts.
- **Configurable Reporting:** Adjust data reporting intervals (e.g., 5 to 3600 seconds) for optimized network stability and performance.

More Data

On the device settings page, click "More Data" to set "Device Locating", "Interval for Data Reporting", and view L1 and L2 electricity data.

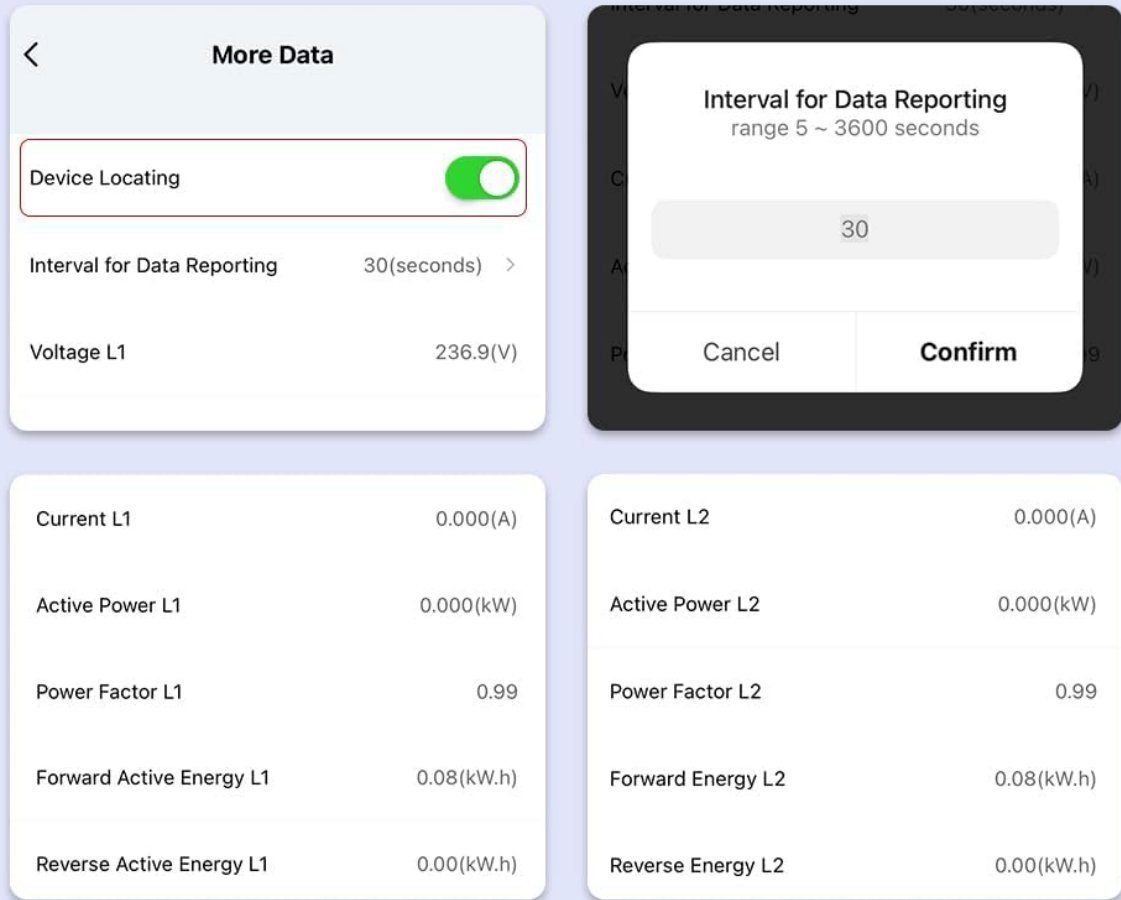

Image 4.2: This image shows the 'More Data' section within the Smart Life app's device settings. It highlights the option to set the 'Interval for Data Reporting' (ranging from 5 to 3600 seconds) and displays detailed electricity data for both L1 and L2, including current, active power, power factor, and forward/reverse active energy.

4.2 Alarm Messages

Configure alarm settings within the app to receive notifications for abnormal electrical data.



Image 4.3: A visual representation of the 'Alarm Messages' feature in the Smart Life app. It shows a phone screen with various alarm types that can be configured, such as high-power alarm, over-current alarm, unbalanced-load alarm, over-voltage alarm, under-voltage alarm, phase-loss alarm, and negative-active-power alarm. These alarms notify the user when electrical data deviates from set thresholds.

- **Alarm Types:** Set alerts for high-power, over-current, unbalanced-load, over-voltage, under-voltage,

phase-loss, and negative-active-power.

- **Customizable Thresholds:** Define specific thresholds for each alarm type to suit your needs.

5. MAINTENANCE

The Blindsmart Smart Home Energy Monitor is designed for minimal maintenance. Ensure the device and its connections remain secure and free from dust or moisture. Periodically check the app for any system updates to ensure optimal performance and access to the latest features.

- **Regular Checks:** Inspect physical connections for any signs of wear or damage.
- **Software Updates:** Keep the Smart Life app and device firmware updated.
- **Cleaning:** Use a dry, soft cloth to clean the exterior of the module. Do not use liquid cleaners.

6. TROUBLESHOOTING

If you encounter issues with your Smart Home Energy Monitor, consider the following:

- **No Data in App:** Ensure the device is properly powered and connected to your Wi-Fi network. Check the status LED on the module. If the LED is not blinking as expected, try resetting the device.
- **Inaccurate Readings:** Verify that the split-core CTs are correctly clamped around the main power lines with the arrows indicating the correct power flow direction. Ensure all wiring is secure.
- **App Connectivity Issues:** Confirm your Wi-Fi network is active and the signal strength is adequate at the device's location. Restart your router and the energy monitor. Re-pair the device with the app if necessary.
- **Alarms Not Triggering:** Check your alarm settings in the Smart Life app to ensure thresholds are correctly configured and notifications are enabled.
- **Device Reset:** If the device is unresponsive, press and hold the reset button on the module for a few seconds until the status LED indicates reset mode (e.g., rapid blinking).

For persistent issues, consult a qualified electrician or contact Blindsmart customer support.

7. SPECIFICATIONS

Detailed technical specifications for the Blindsmart Smart Home Energy Monitor (WiFi Version):

Product Parameters



Image 7.1: This image provides a detailed overview of the product parameters and dimensions for the Blindsmart Smart Home Energy Monitor, model SDM02T-TW. It includes measurements for the monitoring module and the split-core CTs, along with electrical specifications such as rated operating voltage, max current, energy measurement accuracy, and operating temperature.

Specification	Value
Product Model	SDM02T-TW-120A/IEC-ZM
Rated Operating Voltage U_n	110-240 VAC L-N, 50/60 Hz
Max Current I_{max}	120 A
Rated Insulating Voltage U_i	250 V
Rated Impulse Withstand Voltage U_{imp}	4 kV
Energy Measurement Accuracy Class	1% (IEC 61557-12 Class 1 for active energy)
Operating Temperature	-25~70 °C
Maximum Power Consumption	≤ 2 VA
Item Weight	10.2 ounces
Product Dimensions	1.65 x 1.65 x 0.82 inches
Connectivity	2.4GHz Wi-Fi
Control Method	App (Smart Life)

8. WARRANTY AND SUPPORT

For warranty information and customer support, please refer to the documentation included with your product or visit the official Blindsmart website. Keep your purchase receipt for warranty claims.