



[Manuals.plus](#) /

> [Giantex](#) /

> Giantex GT10295-JZWH Rolling Lateral File Cabinet User Manual

## Giantex GT10295-JZWH

# Giantex GT10295-JZWH Rolling Lateral File Cabinet User Manual

Model: GT10295-JZWH

## INTRODUCTION

---

Thank you for choosing the Giantex GT10295-JZWH Rolling Lateral File Cabinet. This manual provides essential information for the safe assembly, operation, maintenance, and troubleshooting of your new cabinet. Please read these instructions carefully before use and retain them for future reference.

This versatile storage solution is designed to help organize your office, living space, or studio. It features a spacious top surface, two large drawers, three small drawers, and a convenient side cabinet, offering diverse storage options. Equipped with five smooth 360° swivel casters, including two lockable wheels, it provides both mobility and stability. Constructed with thickened boards and an extra middle wheel, the cabinet is designed to support up to 220 lbs.



Figure 1: Giantex GT10295-JZWH Rolling Lateral File Cabinet in a home office environment.

# Multi-functional Storage Cabinet



Figure 2: Versatile use of the cabinet in different room settings.

## SAFETY INFORMATION

To ensure safe use and prevent injury or damage, please adhere to the following safety guidelines:

- **Weight Capacity:** Do not exceed the maximum weight capacity of 220 lbs (100 kg) for the entire cabinet. Distribute weight evenly.
- **Stability:** Always engage the two lockable wheels to secure the cabinet in place, especially when loading or unloading items, or when children are present. This prevents accidental movement and tipping.
- **Assembly:** Follow all assembly instructions carefully. Incorrect assembly can compromise the structural integrity and stability of the cabinet.
- **Placement:** Place the cabinet on a flat, level surface. Avoid placing it on uneven ground or near heat sources.
- **Children and Pets:** Keep children and pets away from the cabinet during assembly. Do not allow children to climb on or play with the cabinet or its drawers.
- **Moving the Cabinet:** Before moving the cabinet, ensure all drawers are closed and secured, and unlock the wheels. Move slowly and carefully to prevent items from falling or the cabinet from tipping.

## SETUP AND ASSEMBLY

---

Assembly of the Giantex GT10295-JZWH File Cabinet is required. Please ensure you have all components and tools before beginning. A detailed user guide with step-by-step instructions and diagrams is included in the package.

1. **Unpack Components:** Carefully unpack all parts and hardware. Verify that all items listed in the included parts list are present and undamaged.
2. **Identify Parts:** Refer to the assembly manual to identify each component. Lay them out on a clean, soft surface to prevent scratches.
3. **Follow Instructions:** Assemble the cabinet strictly according to the provided user guide. Pay close attention to the orientation of panels and the correct installation of drawer slides and wheels.
4. **Secure Fasteners:** Ensure all screws, bolts, and connectors are tightened securely. Do not overtighten, as this may damage the material.
5. **Install Wheels:** Attach the five 360° swivel casters to the base of the cabinet. Ensure the two lockable wheels are positioned as indicated in the manual for easy access.
6. **Drawer Installation:** Install the drawer slides onto the cabinet frame and then attach the drawers. Ensure they glide smoothly and close properly. If drawers do not close smoothly, recheck the slide installation.



Figure 3: Cabinet dimensions and drawer specifications for assembly reference.



## Details of the File Cabinet



Cut-out Handles



Smooth Slides

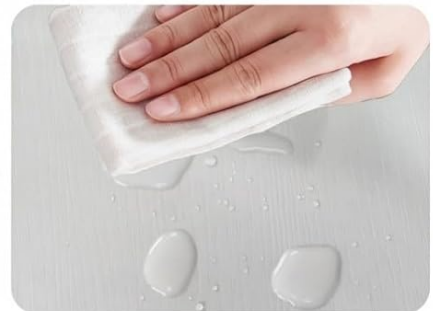

Easy-to-clean Surface

Figure 4: Details of the cabinet's features, including handles and drawer slides.

## OPERATING INSTRUCTIONS

The Giantex GT10295-JZWH File Cabinet is designed for convenient storage and mobility.

- **Using Drawers:** The cabinet features two large drawers, three small drawers, and a side cabinet. Pull the cut-out handles to open drawers. Ensure items are placed within the drawer's capacity and do not obstruct the closing mechanism. Push firmly to close.
- **Mobility:** To move the cabinet, ensure the two lockable wheels are disengaged (unlocked). Gently push or pull the cabinet to its desired location. The 360° swivel casters allow for easy movement in any direction.
- **Securing the Cabinet:** Once the cabinet is in its desired position, engage the locks on the two lockable wheels. This will prevent the cabinet from rolling accidentally and enhance stability.
- **Storage:** Utilize the spacious top surface for printers, decor, or frequently accessed items. The various drawer sizes and side cabinet are suitable for organizing files, office supplies, craft materials, or other personal belongings.

# Specifications

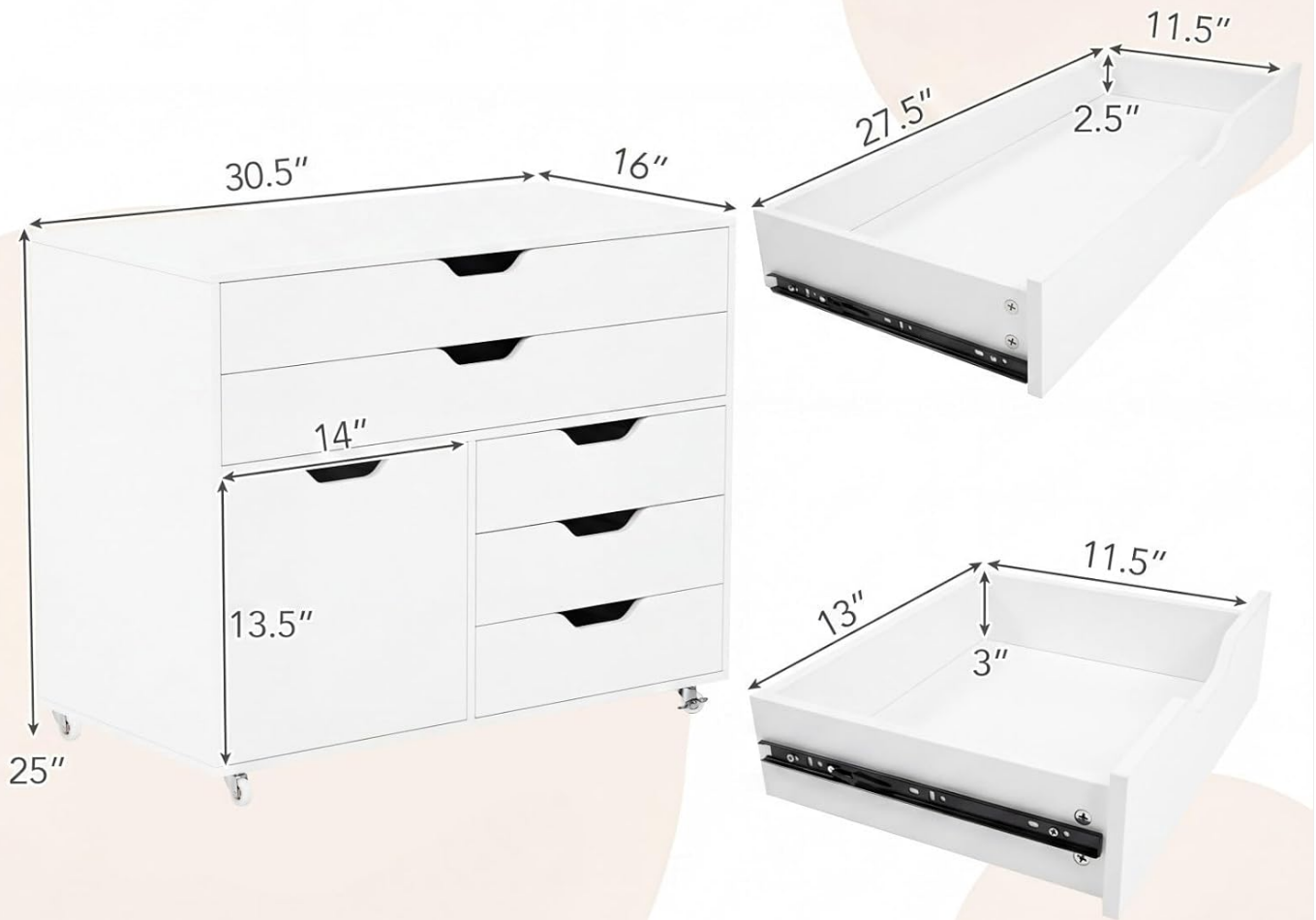

Figure 5: Detail of the cabinet's universal wheels and locking mechanism.

# Five 360° Swivel Universal Wheels



Mute Design



Easy Movement



Extra Middle Wheel  
for Stable Structure



2 Lockable Wheels



Figure 6: Overview of the cabinet's storage compartments.

## MAINTENANCE

Regular maintenance will help prolong the life and appearance of your Giantex File Cabinet.

- **Cleaning:** The cabinet features an easy-to-clean surface. Wipe down surfaces with a soft, damp cloth. Avoid abrasive cleaners or harsh chemicals, as these can damage the finish.
- **Drawer Slides:** Periodically check drawer slides for smooth operation. If they become stiff, a small amount of silicone-based lubricant can be applied.
- **Wheels:** Keep the wheels free of dust and debris to ensure smooth rolling. Check the locking mechanism periodically to ensure it functions correctly.
- **Fasteners:** Over time, fasteners may loosen. Periodically check all screws and bolts and tighten them if necessary to maintain structural integrity.
- **Avoid Overloading:** Do not overload drawers or the top surface beyond the specified weight capacity to prevent structural strain.

## TROUBLESHOOTING

If you encounter any issues with your Giantex File Cabinet, refer to the following common problems and solutions:

Problem	Possible Cause	Solution
Drawers do not close smoothly or completely.	<ul style="list-style-type: none"><li>○ Drawer slides incorrectly installed or misaligned.</li><li>○ Obstruction in the drawer or slide mechanism.</li><li>○ Loose fasteners on drawer slides or cabinet frame.</li></ul>	<ul style="list-style-type: none"><li>○ Review assembly instructions for correct slide installation.</li><li>○ Check for any items blocking the drawer's path.</li><li>○ Tighten all screws on drawer slides and cabinet frame.</li></ul>
Wheels do not lock or unlock properly.	<ul style="list-style-type: none"><li>○ Locking mechanism is jammed or damaged.</li><li>○ Debris caught in the wheel or lock.</li></ul>	<ul style="list-style-type: none"><li>○ Inspect the locking lever and mechanism for obstructions.</li><li>○ Clean any debris from the wheels and locking parts.</li><li>○ Ensure the lever is fully engaged or disengaged.</li></ul>
Cabinet feels unstable or wobbly.	<ul style="list-style-type: none"><li>○ Loose assembly fasteners.</li><li>○ Uneven floor surface.</li><li>○ Overloaded or unevenly distributed weight.</li></ul>	<ul style="list-style-type: none"><li>○ Check and tighten all assembly screws and bolts.</li><li>○ Move the cabinet to a level surface or use shims if necessary.</li><li>○ Reduce weight or redistribute items evenly within the cabinet.</li></ul>
Cabinet arrived with minor cosmetic damage (scratches, chips).	<ul style="list-style-type: none"><li>○ Shipping damage or manufacturing imperfection.</li></ul>	<ul style="list-style-type: none"><li>○ Contact Giantex customer support with details and photos of the damage for assistance.</li></ul>

## SPECIFICATIONS

Feature	Detail
Brand	Giantex
Model Number	GT10295-JZWH
Color	White
Material	Engineered Wood, Metal
Product Dimensions (D x W x H)	40.6D x 77.5W x 63.5H Centimetres (16"D x 30.5"W x 25"H)
Item Weight	59 Pounds (26.76 kg)
Weight Capacity (Maximum)	220 Pounds (100 kg)
Number of Drawers	5 (2 large, 3 small)
Special Feature	Wheeled (5 casters, 2 lockable)
Mounting Type	Freestanding
Assembly Required	Yes

## WARRANTY AND SUPPORT

---

For any questions, concerns, or issues regarding your Giantex GT10295-JZWH Rolling Lateral File Cabinet, please contact Giantex customer support.

- **Return Policy:** This product is eligible for return or refund within 30 days of receipt, subject to the retailer's return policy.
- **Customer Support:** For technical assistance, missing parts, or warranty claims, please visit the official Giantex website or contact their customer service department directly. Refer to the contact information provided in your purchase documentation or on the Giantex brand store page.

