

Manuals.plus /

› SUPERJARE /

› SUPERJARE 5.9 Inch Narrow Console Table with Outlet (Model B0DR8K9CFY) Instruction Manual

SUPERJARE B0DR8K9CFY

SUPERJARE 5.9 Inch Narrow Console Table with Outlet (Model B0DR8K9CFY) Instruction Manual

Brand: SUPERJARE

Model: B0DR8K9CFY

1. INTRODUCTION

The SUPERJARE 5.9 Inch Narrow Console Table with Outlet is designed to optimize space and provide convenient charging solutions for your living area. This versatile table seamlessly fits behind sofas, in entryways, or along walls, transforming unused spaces into functional areas. Its durable construction and integrated charging station make it a practical addition to any home.

Key Features:

- Space-saving narrow design (5.9 inches deep).
- Integrated charging station with 2 AC outlets, 1 USB port, and 2 Type-C ports.
- Durable engineered wood top and sturdy metal frame.
- Modular design allows for connecting multiple tables.
- Adjustable feet for stability on uneven surfaces.
- Includes anti-tipping kits for enhanced security.

2. SETUP AND ASSEMBLY

Assembly of your SUPERJARE console table is designed to be straightforward, typically taking around 16 minutes with the included tools and easy-to-follow instructions.

2.1 Components Overview

The table consists of engineered wood top sections and a robust metal frame. Ensure all components are present before beginning assembly.

3 Colors Available

Product Size

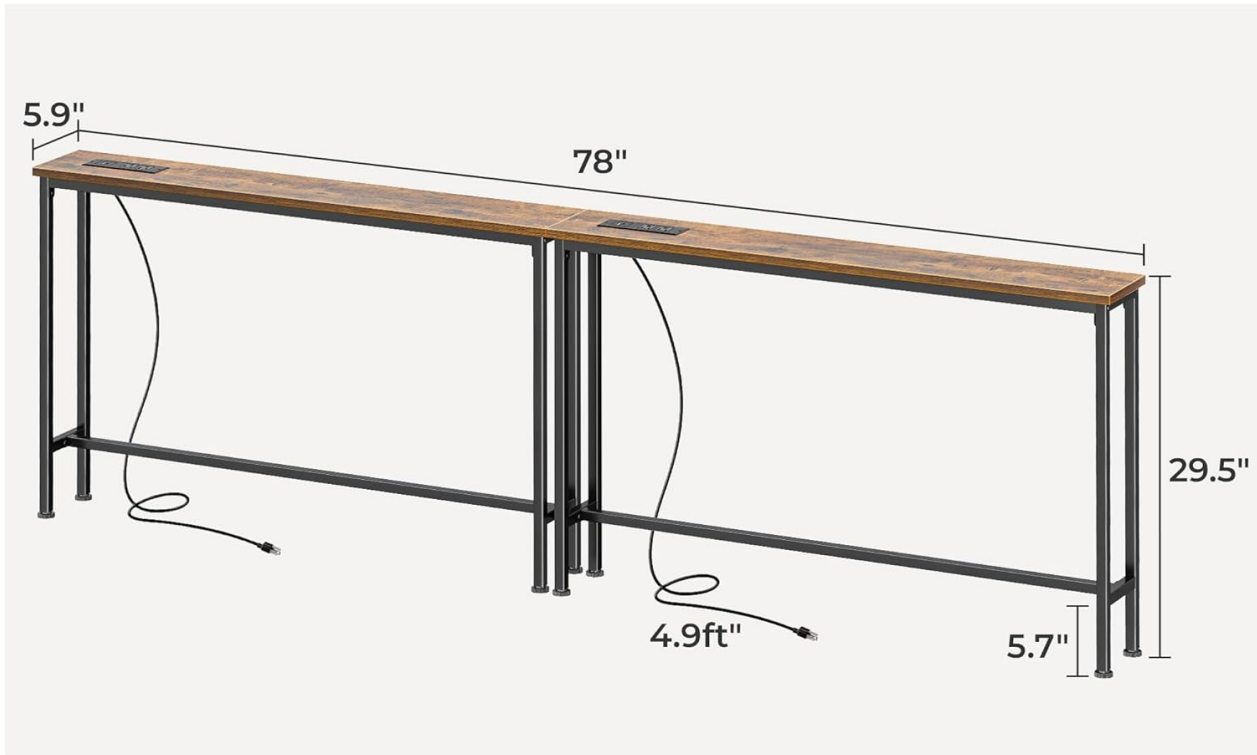

Image: Product size diagram illustrating the dimensions of the console table, including its 5.9-inch depth and 78-inch total length when two units are combined.

2.2 Connecting Multiple Tables

If you have purchased a set of two tables, they can be connected using the provided metal sheets for increased flexibility and length. This creates a continuous surface, ideal for longer sofas or entryways.

Use Sheet Metal to Connect 2 Tables

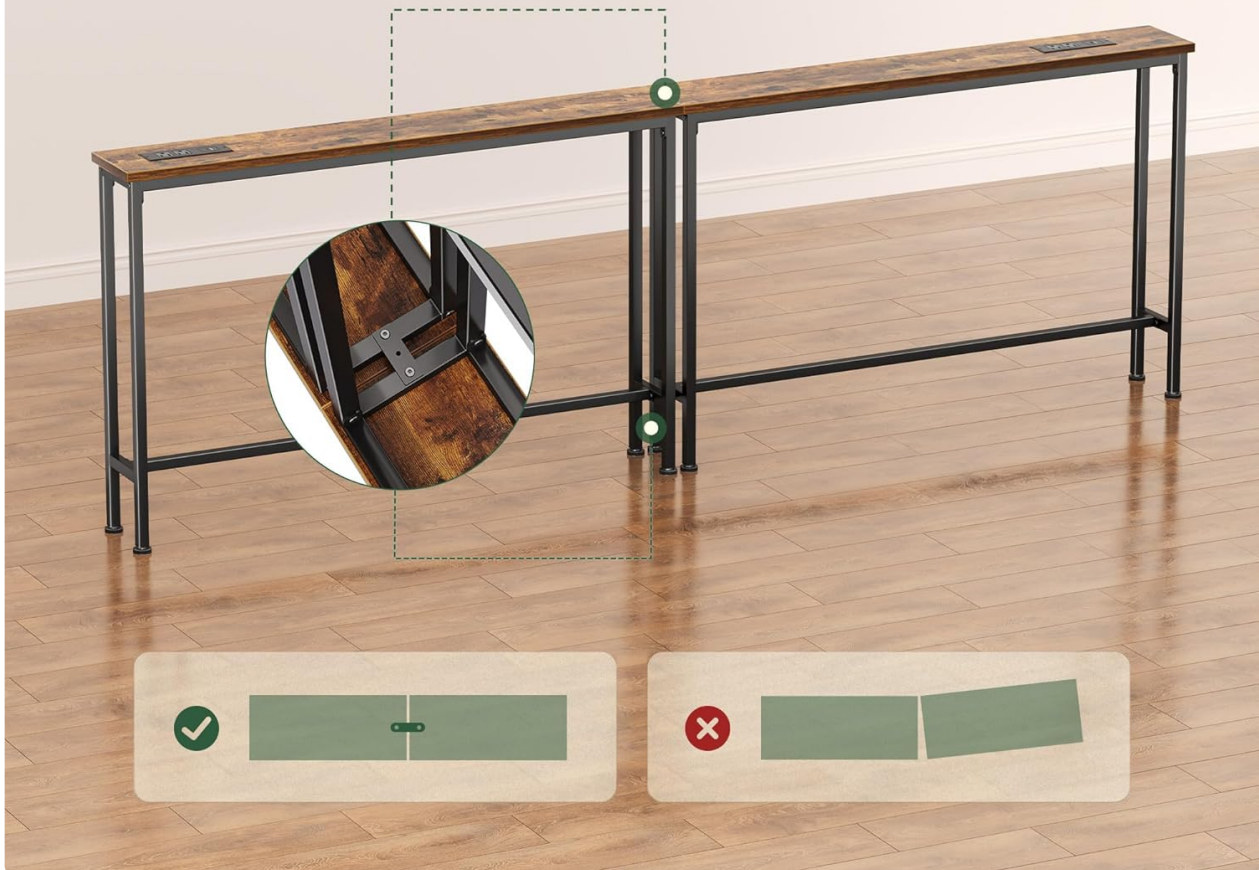

Image: A visual guide demonstrating the use of a metal sheet to securely connect two individual console tables, forming a longer, continuous unit.

2.3 Adjustable Feet

The table is equipped with upgraded adjustable feet. These can be rotated to stabilize the table on uneven floor surfaces, preventing wobbling and ensuring a level display area.

2.4 Anti-Tipping Kit Installation

For enhanced safety and stability, especially in households with children or pets, it is recommended to attach the console table to the wall using the provided anti-tipping kits. Follow the instructions carefully to secure the table.

Anti-Tipping Kits

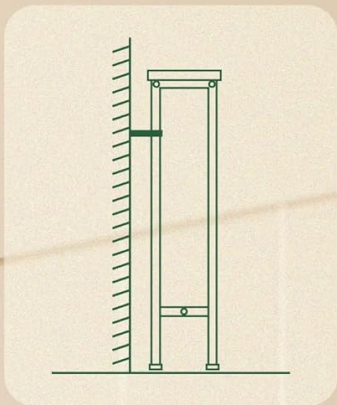

Secure the sofa table to the wall using the kits for enhanced stability.

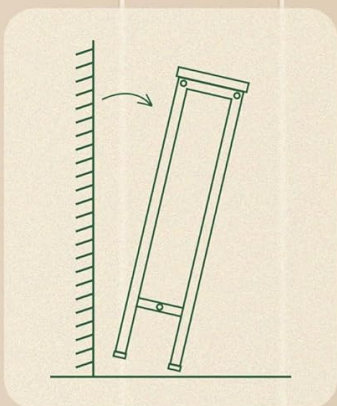

Failure to utilize kits may lead to the table toppling over.

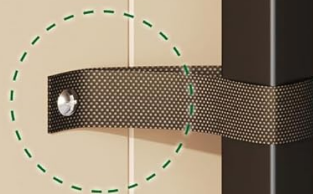

Image: An illustration detailing the proper method for securing the console table to a wall using the anti-tipping kits, highlighting the importance of this step for stability and safety.

3. OPERATING THE CHARGING STATION

The integrated charging station provides convenient power access for your electronic devices.

3.1 Power Outlets and USB Ports

Each charging station features 2 AC outlets (125V/12A), 1 USB port (5V-2A), and 2 Type-C ports (5V-2A). Simply plug in your devices to charge them directly from the table.

Multiple Charging Options



2 AC Outlets
125V/12A



1 TYPE-C
5V-2A



1 USB Port
5V-2A

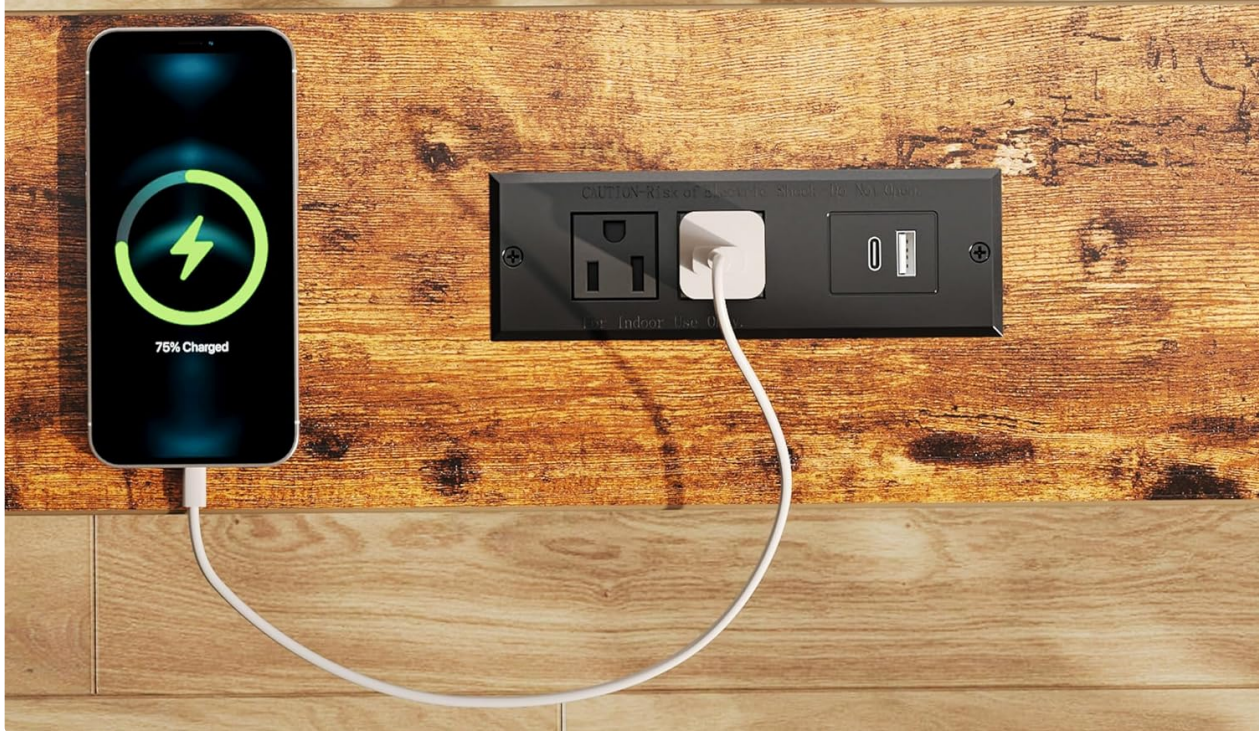

Image: A detailed view of the console table's charging panel, clearly showing the two AC power outlets, one standard USB port, and two USB Type-C ports for various device charging needs.

3.2 Flexible Placement

The charging modules can be positioned either in the middle or at the edge of the table sections, allowing you to customize access based on your setup and preference.

In the Middle or at the Edge

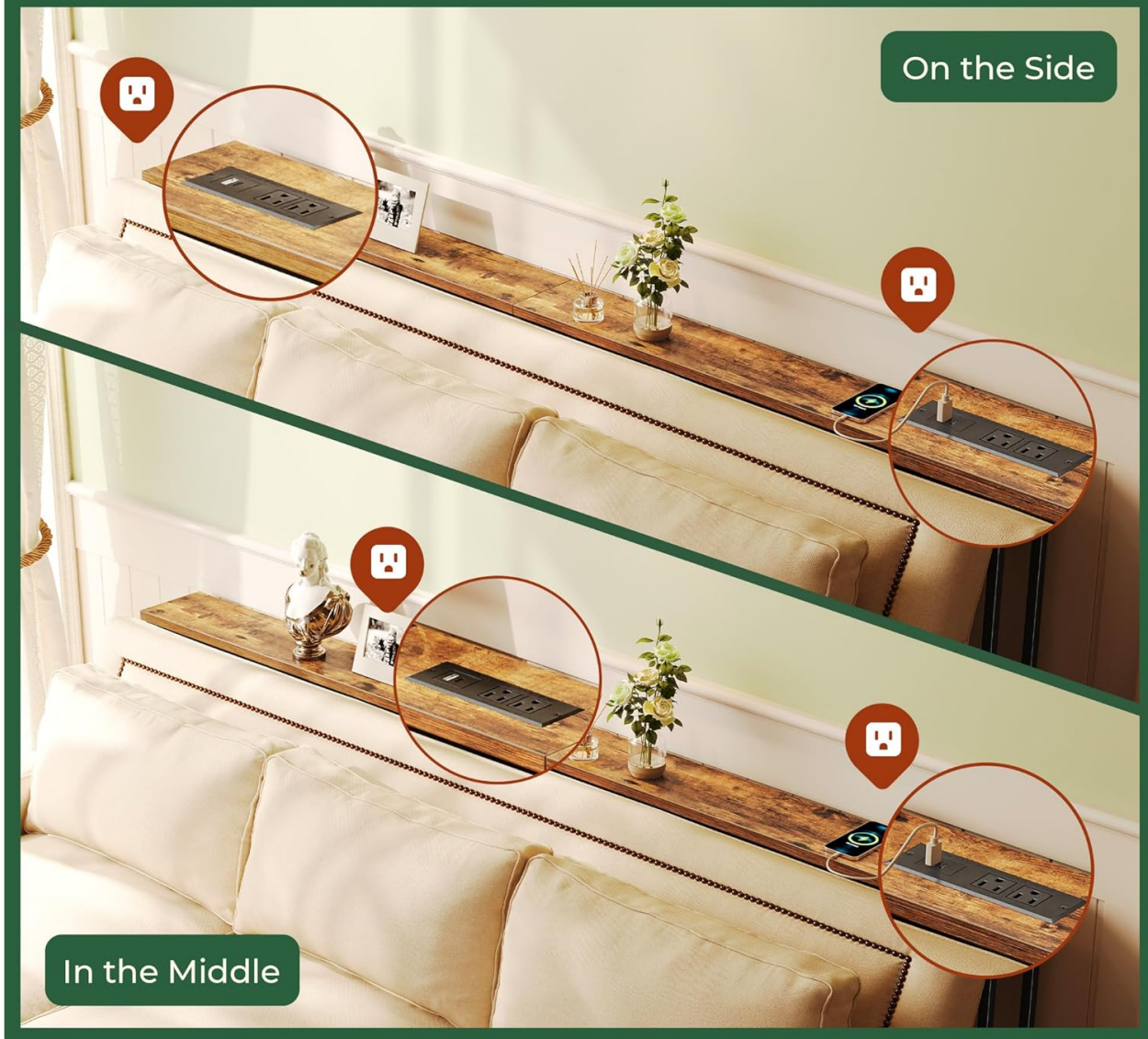

Image: Two comparative images illustrating the versatility of the charging station's placement, showing it installed centrally and at the end of the console table for user convenience.

3.3 Charging Station Demonstration

Your browser does not support the video tag.

Video: This video demonstrates the functionality of the console table's charging station, showcasing its 2 power outlets and 2 USB ports in use.

4. MAINTENANCE

To maintain the appearance and longevity of your console table, follow these simple care instructions:

- Wipe the surface with a damp cloth to remove dust and spills.
- Avoid using harsh chemicals or abrasive cleaners, as these may damage the finish.
- Keep the table away from direct sunlight and excessive moisture to prevent warping or discoloration.

5. TROUBLESHOOTING

5.1 Table Wobbling

If your table appears to wobble, first ensure that the adjustable feet are properly configured to compensate for any unevenness in your floor. If the wobbling persists, especially when placed against a wall with trim, the wall trim might be preventing the table from sitting perfectly flush against the wall.

Your browser does not support the video tag.

Video: This video demonstrates how the console table might wobble due to wall trim and suggests potential solutions to ensure stability.

Consider using additional wall anchors or furniture pads to create a more stable fit if wall trim is an issue. The anti-tipping kits provided can also help secure the table more firmly to the wall.

6. SPECIFICATIONS

Attribute	Detail
Brand	SUPERJARE
Product Dimensions	5.9"D x 78"W x 29.5"H (for set of 2)
Item Weight	17.4 Pounds
Maximum Weight Recommendation	22 Pounds
Frame Material	Metal
Top Material Type	Engineered Wood
Color	Rustic Brown
Number of Items	2
Indoor/Outdoor Usage	Indoor
Tools Recommended For Assembly	Screw Driver

7. WARRANTY AND SUPPORT

For warranty information, product support, or to inquire about replacement parts, please contact SUPERJARE customer service directly. Refer to your purchase documentation for specific contact details or visit the official SUPERJARE website.