

SISESOL SISESOL

SISESOL 2-Drawer File Cabinet with Lock

Model: SISESOL

1. INTRODUCTION

Thank you for choosing the SISESOL 2-Drawer File Cabinet. This manual provides essential information for the safe assembly, operation, and maintenance of your new file cabinet. Please read these instructions thoroughly before beginning assembly or use, and retain this manual for future reference.

This metal file cabinet is designed for organizing letter-size documents and folders, featuring two spacious drawers, a secure locking mechanism, and a durable construction suitable for home or office environments.

2. SAFETY INFORMATION

- **Weight Limit:** The top surface of the cabinet can support up to 120 pounds. Do not exceed this weight limit.
- **Stability:** This cabinet features an anti-tip interlock system, allowing only one drawer to be opened at a time to prevent tipping. Always ensure the cabinet is on a stable, level surface.
- **Handling:** Handle with care when moving the cabinet, especially when fully loaded, to prevent injuries.
- **Children and Pets:** Keep children and pets away from the cabinet during assembly. Do not allow children to climb on or play with the cabinet.
- **Assembly:** Follow all assembly instructions carefully. Ensure all screws and fasteners are securely tightened before use.

3. PACKAGE CONTENTS

Before assembly, verify that all components are present and undamaged. If any parts are missing or damaged, please contact SISESOL customer support.

- Cabinet Panels (Top, Bottom, Sides, Back)
- Drawer Components (Front, Back, Sides, Bottom)

- Drawer Slide Rails
- Adjustable Hanging Bars
- Lock Mechanism with 2 Keys
- 4 Stand Feet
- Assembly Hardware (Screws, bolts, etc.)
- Instruction Manual

4. SETUP AND ASSEMBLY

Assembly of the SISESOL 2-Drawer File Cabinet is required. It is recommended to have a second person assist with assembly for ease and safety. The estimated assembly time is approximately 30 minutes.

4.1 Tools Required

- Phillips Head Screwdriver (not included)

4.2 Assembly Steps

1. **Unpack Components:** Carefully remove all parts from the packaging and lay them out on a clean, soft surface to prevent scratches. Identify each part using the provided parts list in the separate assembly instructions.
2. **Assemble the Cabinet Frame:** Attach the side panels to the back panel, followed by the top and bottom panels, using the provided screws. Ensure all connections are secure.
3. **Install Drawer Slide Rails:** Attach the drawer slide rails to the inside of the cabinet frame and to the drawer sides as per the detailed assembly diagram. Ensure they are correctly oriented for smooth operation.
4. **Assemble Drawers:** Construct each drawer by attaching the front, back, and side panels to the drawer bottom. Insert the assembled drawers onto the installed slide rails.
5. **Install Lock Mechanism:** Secure the lock mechanism to the designated area on the top drawer. Test the lock with the provided keys.
6. **Attach Stand Feet:** Securely attach the four stand feet to the bottom of the cabinet.
7. **Final Check:** Verify that all screws are tightened and the cabinet is stable. Test both drawers for smooth opening and closing.

For a visual guide, please refer to the installation video available on the product details page where this item was purchased.

PRODUCT DEMENSION

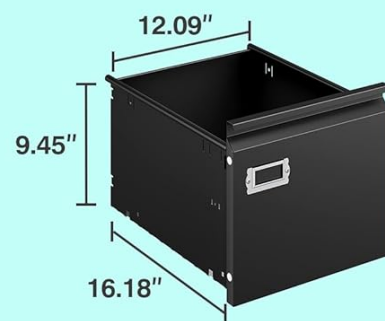

Assembly Required

Image: Product dimensions and assembly time indication.

ANTI-TIP INTERLOCK SYSTEM

Only allow **1** drawer to be opened at one time to prevent the cabinet from tipping over.

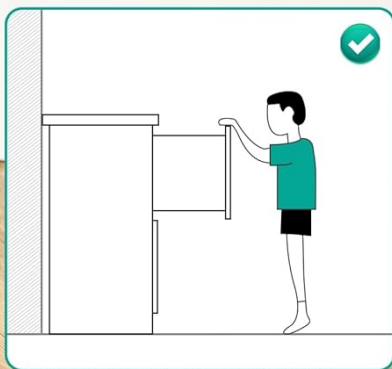
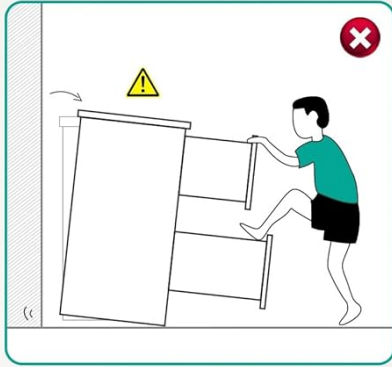

Image: Anti-tip interlock system demonstration.

5. OPERATING INSTRUCTIONS

5.1 Opening and Closing Drawers

The drawers are equipped with smooth slide rails for quiet and easy operation. Pull the drawer handle to open and push to close. Ensure no obstructions are present in the drawer path.

5.2 Using the Lock

The top drawer features a lock mechanism. Insert one of the provided keys into the lock and turn to secure or unlock the drawer. The lock is designed to secure both drawers simultaneously. Always remove the key after locking to prevent loss.

5.3 Adjustable Hanging Bar

Each drawer includes an adjustable hanging bar to accommodate various file sizes, including Letter, A4, F4, B5, and Legal. Adjust the bar by sliding it along the designated slots within the drawer to fit your specific file folders.



Image: Key features including lock, slide rails, and adjustable hanging bar.



Adjustable Hanging Bar



Letter



A4 Size



File Box



B5 / F4 / Legal

Image: Adjustable hanging bar and compatible file sizes.

6. MAINTENANCE

- **Cleaning:** Wipe the cabinet surfaces with a soft, damp cloth. Avoid abrasive cleaners or harsh chemicals that could damage the powder-coated finish.
- **Inspection:** Periodically check all screws and fasteners to ensure they remain tight. Re-tighten if necessary.
- **Lubrication:** If drawer slides become stiff over time, a small amount of silicone-based lubricant can be applied to the rails.
- **Corrosion Prevention:** The cabinet is coated with an electrostatic phosphorus-free epoxy spray coating for rust and corrosion resistance. Avoid prolonged exposure to moisture.

7. TROUBLESHOOTING

If you encounter issues with your SISESOL file cabinet, refer to the following common problems and solutions:

Problem	Possible Cause	Solution
Drawers do not open or close smoothly.	Misaligned drawer slides; obstructions; loose hardware.	Check that drawer slides are correctly installed and aligned. Ensure no items are blocking the drawer path. Verify all assembly hardware is tight. Apply lubricant if necessary.
Lock mechanism is not working.	Key not fully inserted; mechanism jammed; incorrect assembly.	Ensure the key is fully inserted and turned correctly. Check for any foreign objects in the lock. Review assembly steps for the lock mechanism.
Cabinet feels unstable or wobbly.	Uneven surface; loose assembly hardware.	Place the cabinet on a flat, level surface. Re-tighten all assembly screws and bolts.
Only one drawer opens at a time.	This is normal operation.	The cabinet features an anti-tip interlock system for safety. This is a design feature, not a malfunction.

8. SPECIFICATIONS

Feature	Detail
Brand	SISESOL
Model Name	SISESOL
Color	Black
Product Dimensions (D x W x H)	17.9" x 14.2" x 24.6"
Item Weight	51 Pounds
Weight Limit (Top)	120 Pounds
Material Type	Metal
Finish Type	Powder Coated
Number of Drawers	2
Special Feature	Lockable, Anti-tip Interlock System
Recommended Uses	Files & Folders (Letter Size compatible)
Assembly Required	Yes

9. WARRANTY INFORMATION

Specific warranty details are not provided within this instruction manual. For information regarding the product warranty, please refer to the product listing on the retailer's website or contact SISESOL customer support directly.

10. CUSTOMER SUPPORT

If you have any questions, require assistance with assembly, or need to report missing/damaged parts, please contact SISESOL customer support through the retailer's platform where the product was purchased. Please have your product model and purchase date available when contacting support.

11. PRODUCT VIDEOS

No official product videos with 'Seller' as 'creator_type' were found in the provided product data to embed in this manual.

