

## OPMOD YAMA-U-CG-1

# OPMOD HellRazr YAMA Charcoal Grill (Model YAMA-U-CG-1) Instruction Manual

## 1. INTRODUCTION

---

This manual provides essential information for the safe and effective use of your OPMOD HellRazr YAMA Charcoal Grill. Please read all instructions carefully before assembly, operation, or maintenance to ensure proper function and safety.

### Important Safety Information

- Always operate the grill outdoors in a well-ventilated area.
- Keep children and pets away from the grill during use.
- Use heat-resistant gloves when handling hot components.
- Never use gasoline, kerosene, or alcohol to light charcoal. Use only charcoal starter fluid or approved fire starters.
- Ensure the grill is on a stable, non-combustible surface.
- Allow the grill to cool completely before cleaning or moving.

## 2. PRODUCT OVERVIEW

---

The OPMOD HellRazr YAMA Charcoal Grill, Model YAMA-U-CG-1, is a robust outdoor cooking unit designed for versatility. It features a durable construction and multiple cooking configurations.

### Key Features

- 1/4 inch thick precision laser cut carbon steel grills.
- Functions as a plancha griddle, offset smoker, live fire grill, and indexable skewer grill.
- Thick double-walled firebox for enhanced heat retention.
- Removable side door for easy cleaning and use as a reverse flow smoker.
- Portable design.

- Constructed for durability and long-term use.
- Ceramic, silicon-based paint resistant up to 1200°F.



Figure 2.1: The OPMOD HellRazr YAMA Charcoal Grill with the lid open, showcasing the cooking grates and internal structure.



Figure 2.2: Front view of the OPMOD HellRazr YAMA Charcoal Grill in its closed position, highlighting its compact design.

### 3. SETUP

The OPMOD HellRazr YAMA Charcoal Grill is designed for minimal assembly. Most components are pre-assembled for your convenience.

## Initial Setup Steps

1. Remove all packaging materials and inspect the grill for any shipping damage.
2. Place the grill on a flat, stable, and heat-resistant surface outdoors.
3. Ensure all handles and adjustable components are securely fastened.
4. Before first use, it is recommended to perform a burn-in cycle. Load a small amount of charcoal, light it, and allow it to burn for 30-60 minutes with the lid closed to cure the paint and remove any manufacturing residues.



Figure 3.1: Rear view of the grill, showing the robust construction and hinges.

## 4. OPERATING INSTRUCTIONS

The YAMA Charcoal Grill offers various cooking methods. Always ensure proper ventilation and safety precautions during operation.

### 4.1. Charcoal Loading and Lighting

1. Open the grill lid.
2. Place charcoal briquettes or lump charcoal into the designated charcoal tray at the bottom of the firebox. Do not overfill.
3. Use an approved charcoal starter (e.g., chimney starter, electric starter, or solid fire starters) to light the charcoal. Follow the starter product's instructions.
4. Once the charcoal is fully lit and covered with a light gray ash, spread it evenly or arrange it for direct/indirect cooking as desired.

### 4.2. Cooking Configurations

The grill's design allows for multiple cooking styles:

- **Direct Grilling:** Place food directly over the hot charcoal for searing and high-heat cooking. The grill grates are adjustable in height.
- **Indirect Grilling/Smoking:** Arrange charcoal on one side of the firebox and food on the other, or utilize the offset smoker function. The double-walled firebox aids in heat retention, potentially up to 24 hours with appropriate charcoal like OPMOD HellRazr Tex-Mex-Mix Oak & Mesquite Charcoal.
- **Plancha Griddle:** Use the flat griddle plates for cooking items that require a solid surface.

- **Indexable Skewer Grill:** Utilize the integrated skewer slots for rotisserie-style cooking with skewers.



Figure 4.1: The grill open, illustrating the skewer slots and the main cooking grates.



Figure 4.2: A detailed view of the precision laser-cut carbon steel grates and a compatible spatula.

### 4.3. Heat Management

The grill features adjustable air vents to control airflow to the charcoal, which directly impacts cooking temperature. Adjust these vents to increase or decrease heat as needed. The adjustable height grill configuration also allows for varying cooking intensity.

## 5. MAINTENANCE

Regular cleaning and maintenance will extend the life of your grill and ensure optimal performance.

## 5.1. Cleaning After Each Use

1. Allow the grill to cool completely.
2. Remove cooking grates and clean them with a grill brush. For stubborn residue, soak in warm, soapy water.
3. Empty the ash from the charcoal tray. The removable side door facilitates access for cleaning the firebox.
4. Wipe down interior and exterior surfaces with a damp cloth. Avoid abrasive cleaners that could damage the ceramic, silicon-based paint.



Figure 5.1: Side view demonstrating the removable ash tray for convenient cleaning.

## 5.2. Long-Term Storage

When storing the grill for extended periods, ensure it is clean and dry. Store in a covered area to protect it from the elements.

## 6. TROUBLESHOOTING

This section addresses common issues you might encounter with your charcoal grill.

### Common Issues and Solutions

- **Difficulty Lighting Charcoal:** Ensure charcoal is dry. Use sufficient starter fluid or a chimney starter. Check for adequate airflow.
- **Temperature Too Low:** Open air vents fully to increase airflow. Add more charcoal if needed. Ensure the lid is closed to retain heat.
- **Temperature Too High:** Partially close air vents to reduce airflow. Avoid opening the lid frequently.
- **Uneven Cooking:** Distribute charcoal evenly for direct heat. For indirect cooking, ensure food is positioned correctly away from direct heat. Rotate food as necessary.
- **Excessive Smoke:** This is normal during initial lighting. If it persists, ensure proper airflow and that no grease is dripping directly onto the coals.

## 7. SPECIFICATIONS

Feature	Detail
Brand	OPMOD
Model Name	YAMA-U-CG-1
Fuel Type	Charcoal
Assembly Required	No
Handle Material	Stainless Steel
Frame Material	Stainless Steel
Installation Type	Free Standing
Number of Racks	1
Heating Elements	1
Indoor/Outdoor Usage	Outdoor
Grill Configuration	Adjustable Height
Cooking System	Charcoal with Smoker Function
Item Weight	96.8 pounds
Package Dimensions	27 x 19.5 x 17 inches
UPC	810089414786

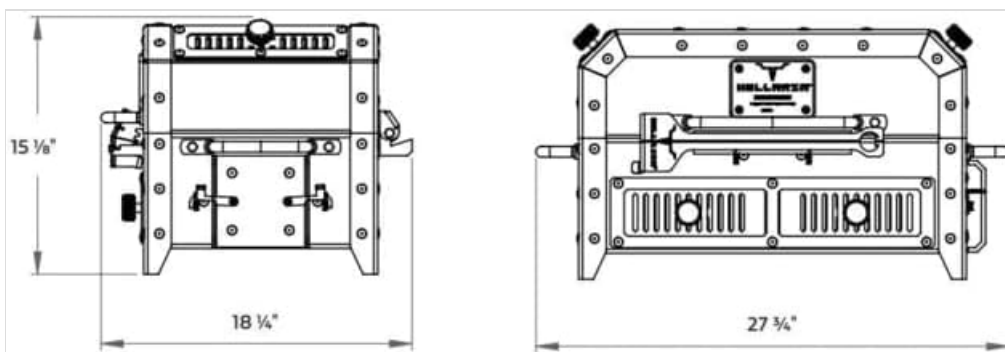

Figure 7.1: Dimensional drawing of the grill, indicating key measurements.

## 8. WARRANTY AND SUPPORT

---

### Warranty Information

The OPMOD HellRazr YAMA Charcoal Grill comes with a **Lifetime Warranty** against manufacturer's defects. This warranty covers defects in materials and workmanship under normal use and service. For specific details regarding warranty claims, please refer to the official OPMOD warranty policy or contact customer support.

### Customer Support

If you have any questions, require assistance, or need to report a defect, please contact OPMOD customer support through their official website or the retailer where the product was purchased. Please have your model number (YAMA-U-CG-1) and proof of purchase available when contacting support.