

Manuals+

[Q & A](#) | [Deep Search](#) | [Upload](#)

[manuals.plus](#) /

› [DH FitLife](#) /

› [DH FitLife Door Frame Pull-up Bar Instruction Manual](#)

DH FitLife GDG02

DH FitLife Door Frame Pull-up Bar Instruction Manual

Model: GDG02

1. INTRODUCTION

The DH FitLife Door Frame Pull-up Bar is a versatile and convenient fitness tool designed for home use. It allows for a variety of upper body and core exercises without the need for permanent installation or drilling. Its quick setup and foldable design make it ideal for space-saving storage. This manual provides essential information for safe and effective use of your pull-up bar.



The DH FitLife Door Frame Pull-up Bar, shown with the included sling trainer, ready for use.

Key Features:

- **Immediate Application:** Ready to use in 30 seconds, no screws or drilling required.
- **High Load Capacity:** Supports up to 200 kg (440 lbs).
- **Multi-functional 4-in-1 Design:** Suitable for pull-ups (various grips), leg raises, push-ups, and exercises with the included sling trainer.
- **Ergonomic Design:** Features angled handles and non-slip foam grips for comfort and injury prevention.
- **Door Frame Protection:** Equipped with rubber caps and a protective bar to prevent damage to your door frame and walls.

2. SAFETY GUIDELINES

Your safety is paramount. Please read and adhere to all safety instructions before using the DH FitLife Pull-up Bar.

- **Weight Limit:** Do not exceed the maximum load capacity of 200 kg (440 lbs).

- **Door Frame Compatibility:** Ensure your door frame is sturdy and can support your weight plus the bar's weight. The bar is designed for door frames between 70-92 cm (27.5-36.2 inches) wide, with a depth of 1.2-2 cm (0.47-0.78 inches) and a maximum trim width of 9 cm (3.5 inches).
- **Secure Installation:** Always ensure the pull-up bar is securely fixed to the door frame before each use. Verify that the protective bar and door hooks are properly engaged.
- **Inspect Before Use:** Before each workout, check the bar for any signs of wear, damage, or loose parts. Do not use if damaged.
- **Proper Technique:** Use proper exercise form to prevent injuries. If you are unsure, consult a fitness professional.
- **Children and Pets:** Keep children and pets away from the equipment during use.
- **Floor Use:** When using the bar for push-ups or dips on the floor, ensure it is placed on a stable, non-slip surface.

CAPACITÉ DE CHARGE

200KG



The DH FitLife pull-up bar is built to support a maximum load of 200 kg, ensuring stability during intense workouts.

3. PRODUCT COMPONENTS

The DH FitLife Door Frame Pull-up Bar package includes the following components:

- DH FitLife Door Frame Pull-up Bar (main unit with ergonomic and hammer grips)
- Sling Trainer (two training harnesses)

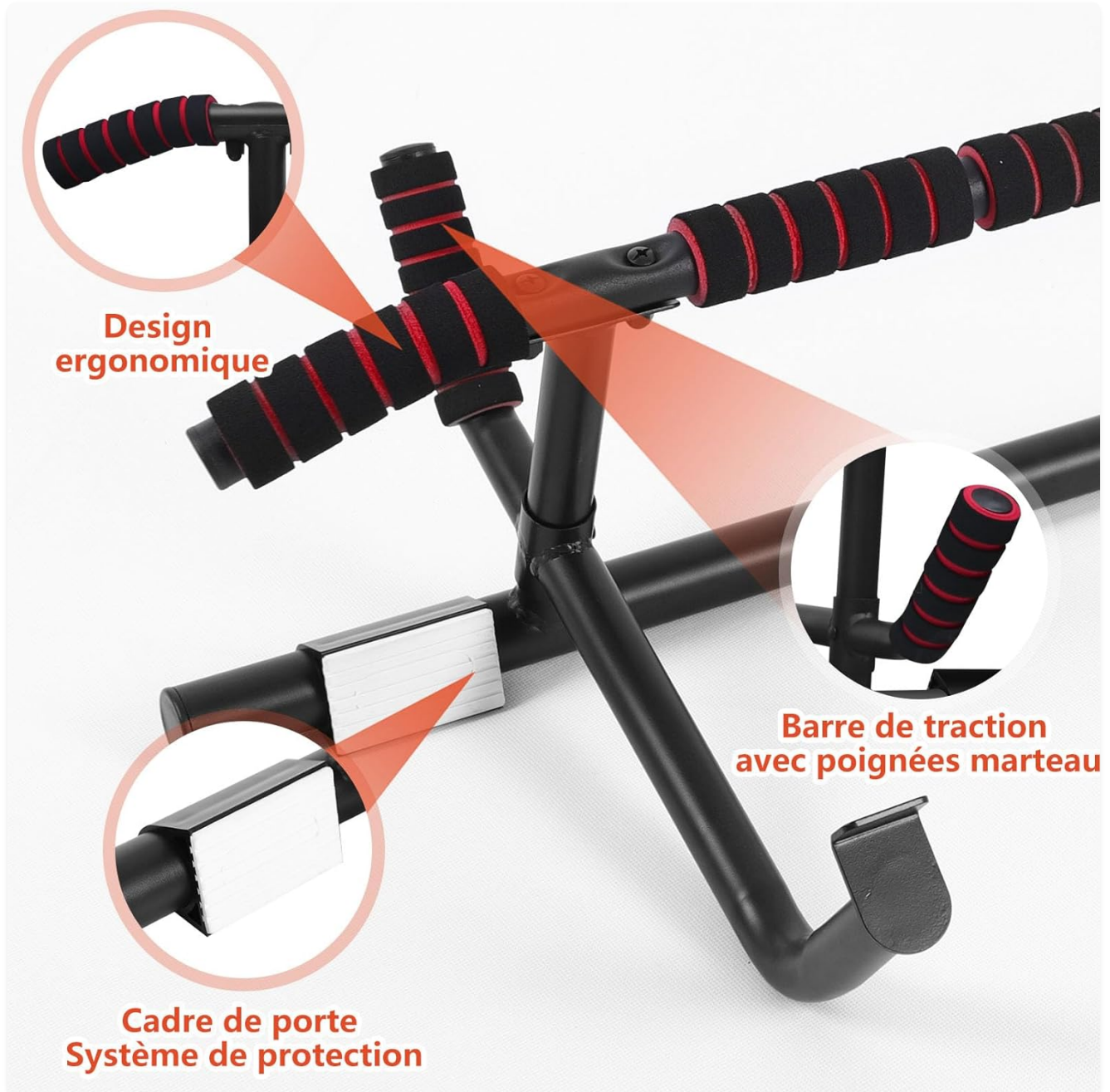

Detailed view of the pull-up bar's ergonomic design, hammer grips, and the protective system for the door frame.

4. INSTALLATION

The DH FitLife Pull-up Bar is designed for quick and easy installation without the need for screws or drilling. It's ready in just 30 seconds!

Step-by-Step Installation:

1. **Measure Your Door Frame:** Before purchase and installation, ensure your door frame meets the required dimensions. The bar fits door frames between 70-92 cm (27.5-36.2 inches) wide. The door frame depth should be 1.2-2 cm (0.47-0.78 inches), and the maximum trim width should be 9 cm (3.5 inches).
2. **Unfold the Bar:** Carefully unfold the pull-up bar until it locks into its open position.
3. **Position on Door Frame:** Place the pull-up bar on the top of your door frame, ensuring the main bar rests against the door frame and the protective bar sits on the opposite side of the frame. The two door hooks should securely engage with the door frame.
4. **Verify Stability:** Gently pull down on the bar to ensure it is stable and securely fixed. The double protection system (protective bar and two door hooks) ensures constant stability.
5. **Begin Your Workout:** Once stable, you are ready to start your training.

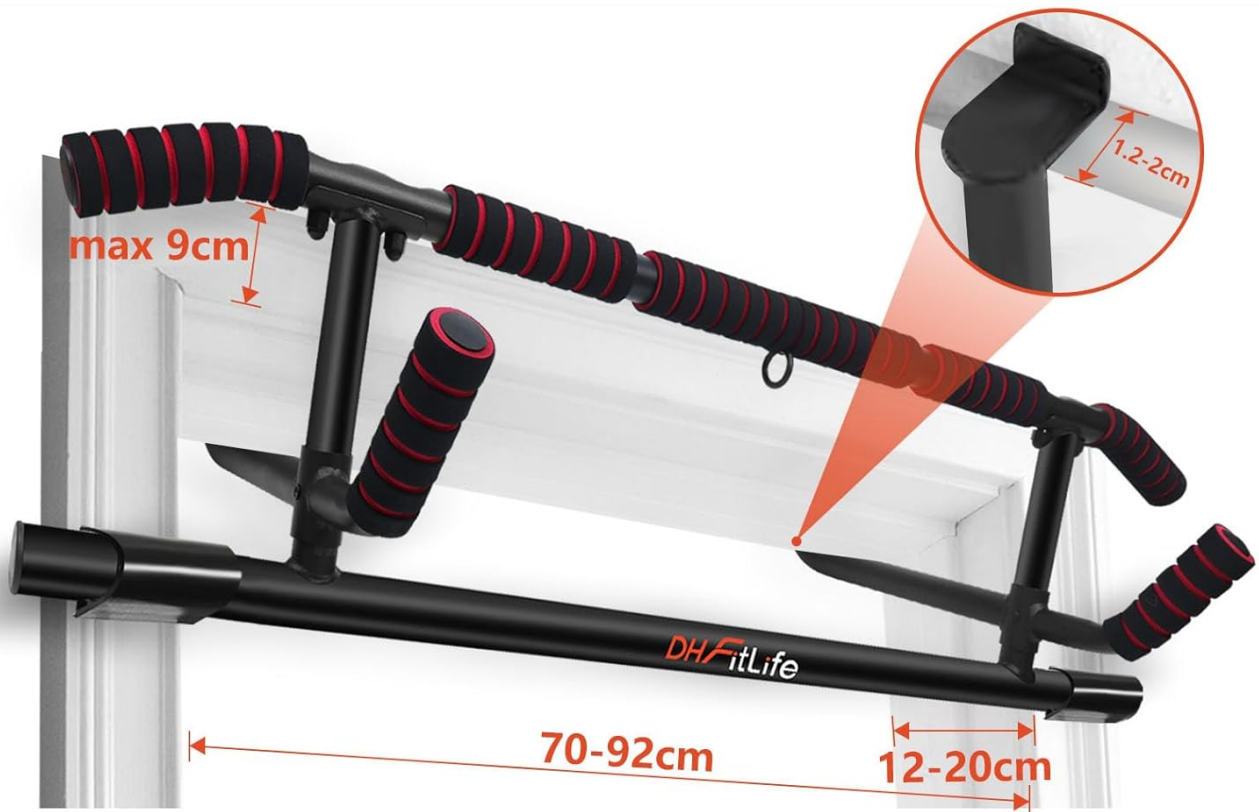

VEUILLEZ MESURER LE CADRE DE LA PORTE !



It is crucial to measure your door frame before installation to ensure compatibility and safety. The image illustrates the required dimensions and types of door frames that are not suitable.

UTILISATION IMMÉDIATE SANS MONTAGE



Sling Trainer
INCLUANT

The pull-up bar is designed for immediate use, requiring no complex assembly or drilling, making it ready in just 30 seconds.

5. USAGE & EXERCISES

The DH FitLife Pull-up Bar offers a 4-in-1 multi-functional design, allowing for a comprehensive full-body workout.

4 IN 1 DESIGN



Pull-ups



Tractions en prise marteau



Pompes



Entraînement à la sangles





The 4-in-1 design allows for a variety of exercises, including pull-ups, hammer grip pull-ups, push-ups, and sling trainer workouts.

Exercise Options:

- **Pull-ups:** Engage your back, chest, shoulders, arms, and core. The bar supports wide, narrow, and parallel grips. The angled handles provide a more stable grip, reducing wrist strain.

DH FitLife[®]
Fitness für Dein Zuhause

Barre de traction de DH-FitLife

-  Prêt à l'emploi en 30 secondes
-  Fabrication de haute qualité
-  Multifonctionnel : tractions, pompes et entraînement complet du corps
-  Design ergonomique
-  Distributeur allemand avec politique de retour de 30 jours



Pull-ups activate multiple muscle groups, providing a comprehensive upper body workout.

- **Hammer Grip Pull-ups (Chin-ups):** With palms facing each other, this grip specifically targets the biceps, shoulders, and upper chest.



Hammer grip pull-ups engage the biceps, shoulders, and upper chest effectively.

- **Leg Raises:** Hang from the bar and raise your legs to engage your lower abdominal muscles and obliques.



Hanging leg raises target the lower abdominal muscles and obliques for core strength.

- **Push-ups:** Place the bar on the floor to use it as a stable base for push-ups, strengthening your chest, triceps, and shoulders.



DESIGN ERGONOMIQUE

Poignées marteau multifonctionnelles

Les poignées parallèles élargissent les possibilités d'entraînement, en particulier pour les tractions serrées.

Push-ups with the bar strengthen your pectoral muscles, triceps, and anterior deltoids.

- **Dips:** Similar to push-ups, the bar can be used on the floor for dips, targeting your triceps and chest.
- **Sling Trainer Exercises:** Attach the included sling trainer to the bar for a wide range of full-body exercises, engaging multiple muscle groups simultaneously.



MEILLEURE DOUBLE SÉCURITÉ AVEC

Plusieurs structures triangulaires

Les embouts en caoutchouc protègent les cadres de porte et les murs, et garantissent un entraînement en toute sécurité à la maison

Full-body training with the sling trainer engages multiple muscle groups simultaneously.

6. CARE & MAINTENANCE

To ensure the longevity and optimal performance of your DH FitLife Pull-up Bar, follow these care and maintenance guidelines:

- **Cleaning:** Wipe down the bar and grips with a damp cloth after each use to remove sweat and dirt. Use mild soap if necessary, then wipe dry.
- **Storage:** After use, the bar can be quickly folded and stored in a dry place away from direct sunlight and extreme temperatures.
- **Inspection:** Periodically check all components, especially the rubber caps and door hooks, for wear and tear. Ensure all connections are secure.
- **Avoid Harsh Chemicals:** Do not use abrasive cleaners or solvents, as they may damage the finish or materials.

7. TROUBLESHOOTING

If you encounter any issues with your DH FitLife Pull-up Bar, please refer to the following common solutions:

- **Bar feels unstable:**

- Ensure the bar is fully unfolded and locked into position.
- Verify that the door hooks are properly engaged with the door frame and the protective bar is flush against the frame.
- Check if your door frame dimensions are within the specified range (70-92cm width, 1.2-2cm depth, max 9cm trim).
- Ensure the door frame itself is sturdy and capable of supporting the weight.

- **Marks on door frame/walls:**

- Ensure the rubber caps are clean and intact.
- Verify that the bar is installed correctly, allowing the rubber caps to bear the pressure evenly.
- Avoid dragging the bar across surfaces during installation or removal.

- **Grips feel loose or worn:**

- Regular cleaning can help maintain grip integrity.
- If grips are significantly worn, contact customer support for possible solutions.

If these steps do not resolve your issue, please contact DH FitLife customer support for further assistance.

8. TECHNICAL SPECIFICATIONS

Feature	Specification
Model Number	GDG02
Brand	DH FitLife
Material	Stainless Steel, Foam, Plastic
Color	Black with Hammer Grips
Maximum Weight Recommendation	200 Kilograms (440 lbs)
Product Dimensions (L x W x H)	100 x 100 x 27 cm (approx. 39.4 x 39.4 x 10.6 inches)
Item Weight	4 Kilograms (8.8 lbs)
Mounting Type	Doorway Mount
Compatible Door Frame Width	70-92 cm (27.5-36.2 inches)
Compatible Door Frame Depth	1.2-2 cm (0.47-0.78 inches)

Feature	Specification
Max Door Frame Trim Width	9 cm (3.5 inches)

9. WARRANTY & SUPPORT

DH FitLife is a German brand committed to customer satisfaction. We work with reliable and qualified teams and trainers to ensure high-quality products.

- **30-Day Return Policy:** If you are not satisfied with our product, DH FitLife offers a 30-day return policy. Please contact customer service to arrange a return.
- **Customer Support:** For any questions, problems, or assistance, please do not hesitate to contact our customer service team. Our sales and customer service are based in Hamburg, Germany.

For more information or to contact support, please visit the official DH FitLife store or contact us through your purchase platform.