



Manuals.plus /

› VDIAGTOOL /

› VDIAGTOOL V500 Pro Automotive Circuit Tester User Manual

VDIAGTOOL VDT-V500-PRO

VDIAGTOOL V500 Pro Automotive Circuit Tester User Manual

Model: VDT-V500-PRO | Brand: VDIAGTOOL

1. INTRODUCTION

The VDIAGTOOL V500 Pro is an all-in-one automotive circuit tester designed to simplify car diagnostics. It covers a wide range of circuit tests including circuit breaker/open test, AC/DC voltage, resistance, positive/negative tests, fuel injector/fuse relay tests, component activation, wire tracing, polarity, continuity, grounding, and trailer light tests. It also features an oscilloscope mode and functions as a digital circuit tester. This tool is dedicated to solving real problems and saving time and money for both professionals and DIYers.



Figure 1: VDIAGTOOL V500 Pro Automotive Circuit Tester Kit

2. WHAT'S IN THE BOX

Your VDIAGTOOL V500 Pro kit comes with everything you need to get started:

- V500 Pro Circuit Probe Tester × 1
- V500 Pro Short Open Circuit Finder × 1
- Probe Tip × 1
- Fine Probe Tip × 1
- Probe Tip Extension Cable × 1
- Wire Piercing Probe × 2
- Banana to Banana Plug Test Lead × 2
- Fuse × 3
- Relay Test Cable × 1
- Alligator Battery Clip × 1
- Type-C Data Cable × 1
- User's Manual × 1

INJECTOR TEST

This feature uses probe tip to output different pulse signals to the injector and check the injector spraying status.

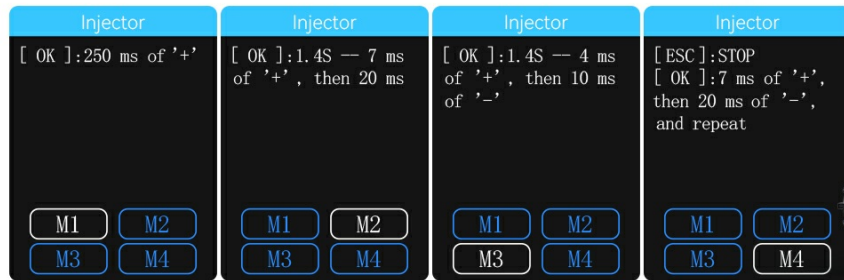

Figure 2: Detailed Packing List

Video 1: Unboxing and contents of the V500 Pro kit.

3. SETUP

3.1 Breaker Finder Battery Installation

Before using the V500 Pro Short Open Circuit Finder, you will need to install a 9V battery (included) into the unit. Ensure the battery is correctly oriented before closing the compartment.

3.2 Connecting to Vehicle Battery

The V500 Pro Circuit Probe Tester operates using the vehicle's battery voltage. Connect the Alligator Battery Clips (red to positive, black to negative) to your vehicle's 9-30V battery terminals. Ensure a secure connection for stable operation.

4. OPERATING MODES

4.1 Probe Mode

In Probe mode, the V500 Pro can perform various circuit tests including positive/negative identification, polarity testing, continuity checks, and grounding tests. It provides real-time voltage readings.

ALL-IN-ONE

Super Probe Circuit Tester & Circuit Breaker Finder



Figure 3: Overview of V500 Pro's All-in-One Capabilities



Video 2: Demonstrates various probe functions and screen rotation.

4.2 Multimeter Mode

The Multimeter mode allows for high-efficiency measurement of various electrical parameters including Voltage (VDC), Resistance (OHM), Diode (DIO), Current (AMP), and Frequency (HZ). This provides comprehensive data for circuit analysis.

MULTIMETER

High-efficiently Measure Full Multimeter Parameters



<p>12.2 V</p> <p>Max: 12.22 Min: 0.00</p> <p>V Ω →</p> <p>A Hz P-N</p> <p>Voltage Test</p>	<p>518.8</p> <p>V Ω →</p> <p>A Hz P-N</p> <p>Resistance Test</p>	<p>(-) → Δ (+)</p> <p>1.74 V</p> <p>7649866</p> <p>V Ω →</p> <p>A Hz P-N</p> <p>Diode Test</p>	<p>0.0 A</p> <p>[DOWN] green on, and start testing</p> <p>V Ω →</p> <p>A Hz P-N</p> <p>Current Test</p>	<p>100 Hz</p> <p>V Ω →</p> <p>A Hz P-N</p> <p>Frequency Test</p>	<p>Probe in:</p> <p>Positive(+)</p> <p>12.2 V</p> <p>V Ω →</p> <p>A Hz P-N</p> <p>Polarity Test</p>
--	--	--	---	--	---

Figure 4: Multimeter Display on V500 Pro

RELAY TEST

Quickly check if the relay is functioning properly

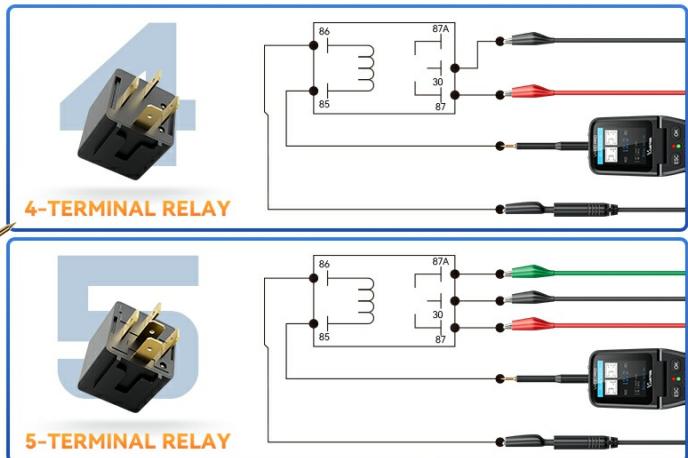

Figure 5: Detailed Multimeter Parameters

4.3 Oscilloscope Mode

The Oscilloscope module graphically displays electrical signals, allowing for intuitive visualization of data fluctuation. This is crucial for analyzing complex waveforms and diagnosing signal-related issues.



Figure 6: Oscilloscope Display on V500 Pro

NOT JUST FOR CARS

Troubleshooting all 12-24V electrical issues



Figure 7: Detailed Oscilloscope Features

4.4 Component Activation

The V500 Pro can provide power to various car components such as bulbs, radiator fans, starter motors, relays, window regulators, and windshield wipers. This feature enables effective testing and troubleshooting by activating components directly.



01

Locating Short Circuits

Switch the V500 Pro Circuit Tester Kit to mode II, you will be able to use the breaker finder which can easily locate the circuit breaker point.

02

4/5-terminal Relay Test

Protective devices and periodic reviews are very important above all for the safe operation of power supply networks.



03

Fuel Injector Test

This feature can help diagnose injector conditions. You can save the cost of going to the garage to diagnose injector problems.

04

Component Activation

V500 PRO can generate activation signals for lights, motors, windshield wipers, radiator fans, relays, fuel injectors and other electrical components to troubleshoot electrical problems.



Figure 8: V500 Pro Displaying Multiple Functions

HIGH BRIGHTNESS SEARCHLIGHT

LED lights can illuminate the dark working environment.



THE SCREEN CAN BE FOLDED UP TO 90°

Allowing you to see real-time data at tight corners and dim angles.

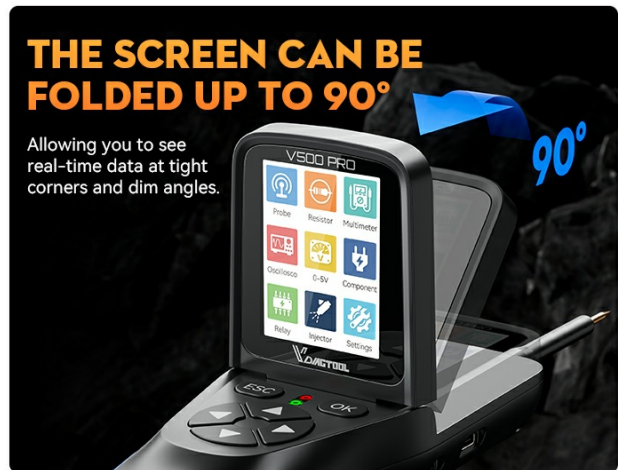

Figure 9: Examples of Component Activation

4.5 Injector Test

This feature uses the probe tip to output different pulse signals to the injector, allowing you to check the injector spraying status and diagnose injector conditions. This can help save on diagnostic costs.



Figure 10: Injector Test Interface

4.6 Relay Test

The V500 Pro includes a dedicated relay test function that quickly checks if a relay is functioning properly. It provides diagrams for both 4-terminal and 5-terminal relays, guiding you through the connection process.

RELAY TEST

Quickly check if the relay is functioning properly

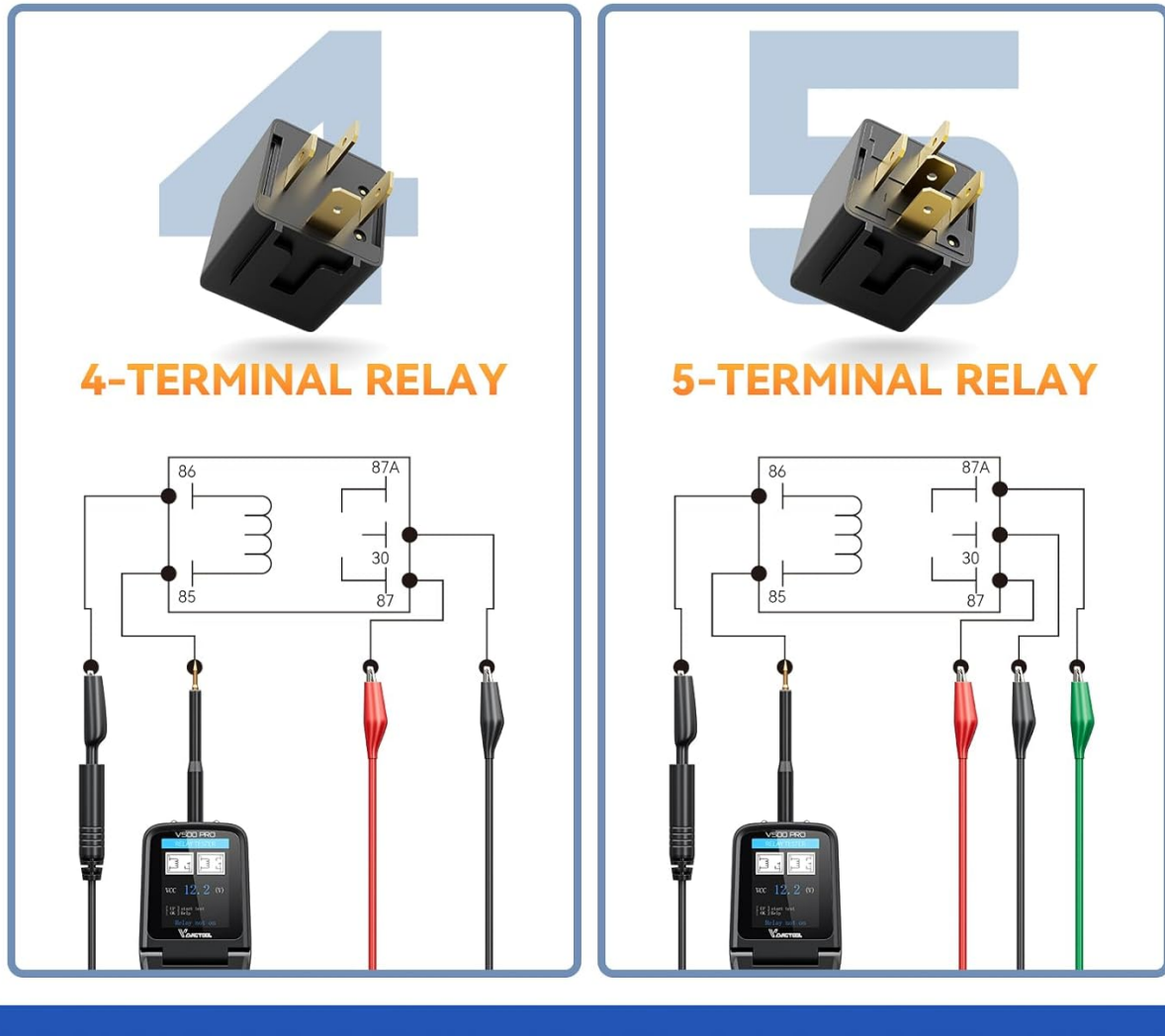
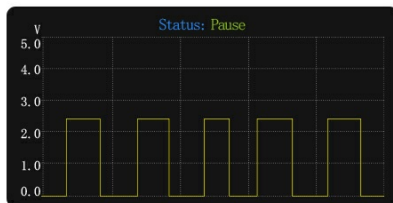

Figure 11: Relay Test Diagrams

OSCILLOSCOPE



TIPS:

The Voltage on the Y axis shows 0.0V to 10.0V and the Time on the X axis shows 1ms to 500ms.

-  :Voltage (DIV / Max / Min)
-  :Pulse Width (Time)
-  :Frequency (Freq)
-  :Duty Cycle (Duty)



Figure 12: Relay Test Function in Use

4.7 Locating Open Circuit / Breaker Finder

Switch the V500 Pro to Mode II to use the breaker finder. This feature can easily locate circuit breaker points, open connections, broken wires, and current leaks with tone changes. It can also trace wires/cables without damaging insulation, making it suitable for various vehicle circuit issues.

LOCATING OPEN CIRCUIT

Free switching of working modes



MODE 1:
Automotive Circuit Tester

MODE 2:
Circuit Breaker Finder

Figure 13: Locating Open Circuit with V500 Pro

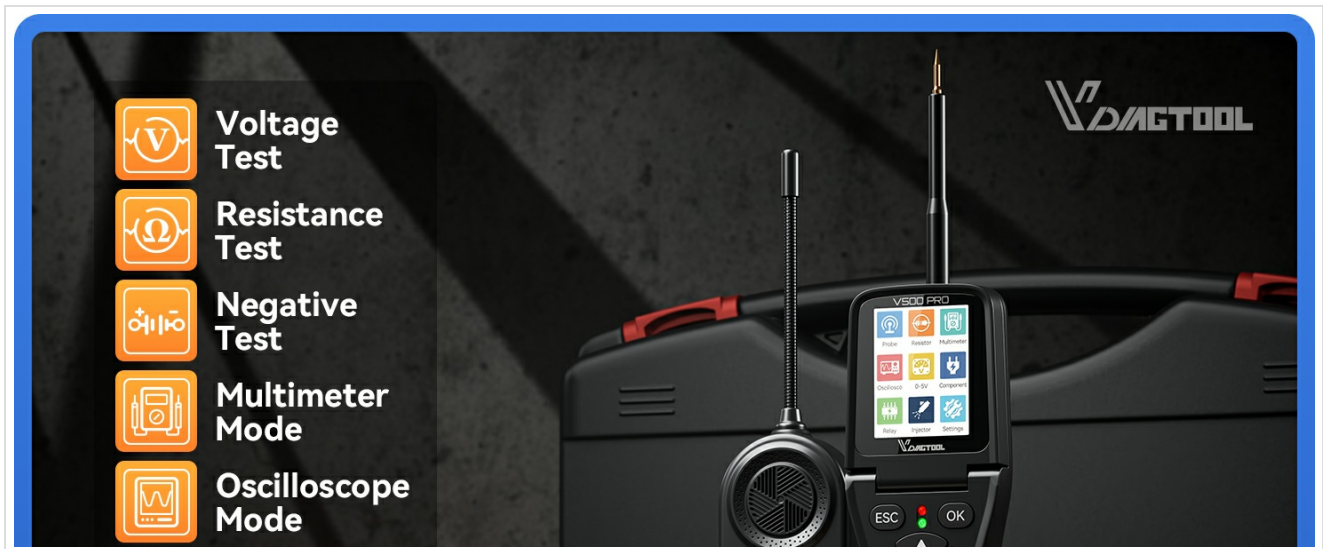

Figure 14: Wire Tracing and Circuit Locating Capabilities

4.8 0-5V Power Supply

The adjustable 0-5V power supply provides a stable, low-voltage output for circuit diagnosis. It can simulate input voltage, debug sensors, test circuit behavior, and calibrate systems, simplifying debugging and optimization processes while preventing component damage.

4.9 90° Rotating Screen

The main screen of the V500 Pro can be rotated 90°, allowing for 360° observation of circuit data without blind spots. This feature enhances focus on analyzing circuit faults from any angle.



Figure 15: Screen Rotation and Built-in Light

5. MAINTENANCE

To ensure the longevity and optimal performance of your VDIAGTOOL V500 Pro, follow these maintenance guidelines:

- Keep the device clean and free from dust and debris. Use a soft, dry cloth for cleaning.
- Store the device in its original carrying case when not in use to protect it from physical damage and environmental factors.
- Avoid exposing the device to extreme temperatures, humidity, or direct sunlight.

- Regularly check the cables and connectors for any signs of wear or damage. Replace them if necessary to prevent electrical hazards.
- Ensure the 9V battery in the breaker finder is replaced when low to maintain accurate readings.

6. TROUBLESHOOTING

If you encounter issues with your VDIAGTOOL V500 Pro, refer to the following common troubleshooting tips:

- **Device Not Powering On:** Ensure the battery clips are securely connected to the vehicle's battery terminals with correct polarity. Check the vehicle battery voltage. For the breaker finder, ensure the 9V battery is installed and has sufficient charge.
- **Inaccurate Readings:** Verify that the probe tip is making good contact with the circuit. Check for any corrosion on the probe or connectors. Ensure the correct operating mode is selected for the test being performed.
- **No Signal Detection (Breaker Finder):** Confirm the breaker finder's 9V battery is functional. Ensure the unit is in Mode II. Check for any breaks or shorts in the wire being traced.
- **Screen Issues:** If the screen is unresponsive or displaying incorrectly, try restarting the device by disconnecting and reconnecting the power.
- **Component Activation Failure:** Verify the component is properly connected and has a good ground. Check the current draw of the component to ensure it's within the tool's operating limits.

For more complex issues or if troubleshooting steps do not resolve the problem, please contact customer support.

7. SPECIFICATIONS

Feature	Specification
Item Model Number	VDT-V500-PRO
Brand	VDIAGTOOL
Color	Black
Min. Operating Voltage	9 Volts
Batteries	1 9V batteries required (included)
Package Dimensions	13.78 x 12.4 x 3.5 inches
Item Weight	5.03 Pounds
Country of Origin	China

8. WARRANTY AND SUPPORT

VDIAGTOOL provides a 3-year free warranty for the V500 Pro Automotive Circuit Tester. Additionally, you are covered by a 60-day no-questions-asked new replacement or refund policy to ensure your complete satisfaction. For any questions, concerns, or technical support, please reach out to our customer service team via email at vdiagtool2@outlook.com. We are committed to providing high-quality products and excellent support.