

## YDuupxe YDuupxebotgdgk9mu

# YDuupxe V2 32-Bit 8-Axis F407 Motherboard with TMC2209 Drivers and LCD Display for 3D Printers User Manual

Model: YDuupxebotgdgk9mu

[Introduction](#) [Safety](#) [Contents](#) [Overview](#) [Setup & Support](#) [Operation](#) [Maintenance](#) [Troubleshooting](#)

[Specifications](#)

## 1. INTRODUCTION

This user manual provides comprehensive instructions for the YDuupxe V2 32-Bit 8-Axis F407 Motherboard with TMC2209 Drivers and LCD Display. This control board is designed for large 3D printers, offering enhanced performance and versatility. Please read this manual thoroughly before installation and operation to ensure proper usage and to maximize the lifespan of your device.

## 2. SAFETY INFORMATION

- Always disconnect power to your 3D printer before installing, removing, or performing maintenance on the motherboard or any electronic components.
- Handle the motherboard with care to avoid electrostatic discharge (ESD) damage. Use an anti-static wrist strap if available.
- Ensure all connections are secure and correctly oriented before applying power. Incorrect wiring can cause damage to the motherboard and other components.
- Do not expose the motherboard to moisture, extreme temperatures, or corrosive environments.
- Keep the motherboard away from children and pets.
- If you are unsure about any step, consult a qualified technician or refer to official support resources.

## 3. PACKAGE CONTENTS

Verify that all items are present in your package:

- YDuupxe V2 32-Bit 8-Axis F407 Motherboard
- MKS Mini12864 LCD Display with Rotary Encoder
- USB Cable
- Various connection cables and jumpers
- Mounting hardware (screws, standoffs)



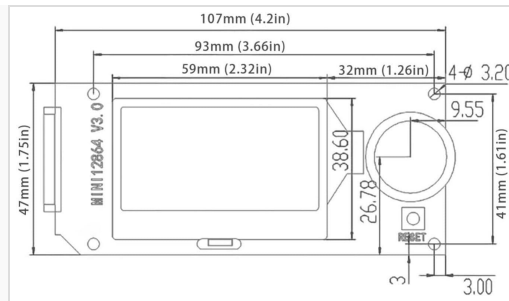

Figure 4.3: MKS Mini12864 LCD Display Dimensions.

## 5. SETUP

### 5.1 Preparation

- Gather necessary tools: screwdrivers, pliers, anti-static mat/wrist strap.
- Ensure your 3D printer is powered off and unplugged from the wall outlet.
- Take photos of existing wiring before disconnecting anything for reference.

### 5.2 Motherboard Installation

Follow these steps to replace your old motherboard with the YDuupxe V2 board:

1. Carefully open the control box of your 3D printer.
2. Disconnect all wires from the old motherboard, noting their positions.
3. Remove the old motherboard from its mounting.
4. Mount the new YDuupxe V2 motherboard in the designated location.
5. Connect the heated bed thermistor.
6. Connect the X, Y, Z, and E motor cables to their respective ports.
7. Connect the X, Y, and Z end stop switches.
8. Connect the hotend thermistor and heater cartridge.
9. Connect the CNC fan and cooling fan cables.
10. Connect the main power supply cables (DC12-24V input).
11. Ensure all connections are firm and correct.

Your browser does not support the video tag. Please update your browser.

Video 5.1: Installation guide for a similar BIGTREETECH motherboard on an Ender 3 printer. This video demonstrates the general process of replacing a 3D printer motherboard and connecting various components like motors, end stops, thermistors, and fans.

Your browser does not support the video tag. Please update your browser.

Video 5.2: Another installation overview for a BIGTREETECH SKR Mini E3 V3.0 board on an Ender 3. This video provides additional visual guidance on connecting the motherboard to a 3D printer's existing wiring.

### 5.3 LCD Display Connection

Connect the MKS Mini12864 LCD display to the motherboard using the provided ribbon cables. Ensure correct orientation of the connectors.

### 5.4 Firmware Update

The motherboard requires appropriate firmware for your specific 3D printer model and configuration. You must update the firmware from the official GitHub repository. Refer to the GitHub documentation for detailed instructions on compiling and flashing the firmware (Marlin2.0.x, Klipper, or RRF).

## 6. OPERATING INSTRUCTIONS

### 6.1 Power On/Off

- **Power On:** Plug in the 3D printer's power cord and turn on the main power switch. The LCD display should light up.
- **Power Off:** Turn off the main power switch and unplug the power cord.

### 6.2 LCD Navigation

The MKS Mini12864 LCD display uses a rotary encoder and a button for navigation:

- **Rotate Encoder:** Scroll through menu options or adjust values.
- **Press Encoder:** Select an option or confirm a setting.
- **Reset Button:** Restarts the motherboard.

## 6.3 Printing

After successful firmware installation and calibration:

1. Prepare your G-code file on a USB disk or MicroSD card.
2. Insert the storage device into the motherboard's slot.
3. Navigate through the LCD menu to select your print file.
4. Confirm to start the print.

## 6.4 Advanced Features

- **Filament Detection:** If enabled in firmware, the printer will pause automatically when filament runs out, allowing you to load new filament and resume.
- **Auto Shutdown:** If configured, the printer can automatically power off after a print job is completed.
- **Print Resume:** In case of power loss, the printer can resume printing from where it left off (requires compatible firmware and settings).

## 7. MAINTENANCE

- **Cleaning:** Periodically clean the motherboard and surrounding area to prevent dust buildup, which can lead to overheating. Use compressed air or a soft brush. Ensure power is disconnected before cleaning.
- **Firmware Updates:** Regularly check the official GitHub repository for new firmware versions. Updates can provide new features, bug fixes, and performance improvements.
- **Connection Inspection:** Periodically inspect all wiring connections to ensure they are secure and free from damage. Loose connections can cause intermittent issues or component failure.
- **Heat Sink Check:** Ensure the heat sink on the main MCU is free of obstructions and properly seated to maintain optimal cooling.

## 8. TROUBLESHOOTING

### 8.1 Common Issues and Solutions

Problem	Possible Cause	Solution
Printer does not power on.	Loose power connection, faulty power supply, incorrect wiring.	Check all power connections. Verify power supply functionality. Re-check wiring against diagrams.
LCD display is blank or shows garbled text.	Incorrect LCD cable connection, incompatible firmware, faulty LCD.	Ensure LCD cables are correctly and securely connected. Verify firmware compatibility and re-flash if necessary.
Motors are not moving or moving incorrectly.	Loose motor cables, incorrect motor wiring, incorrect stepper driver configuration, faulty motor.	Check motor cable connections. Verify motor wiring (e.g., phase order). Ensure stepper drivers are correctly configured in firmware.
Heated bed or hotend not heating.	Loose heater/thermistor connections, faulty heater/thermistor, firmware configuration error.	Check all heater and thermistor connections. Verify thermistor type and heater settings in firmware.
Printer crashes or behaves erratically.	Corrupt firmware, electrical interference, hardware fault.	Re-flash firmware. Ensure proper grounding. Check for loose components or shorts.

## 9. SPECIFICATIONS

- **Model Number:** YDuupxebotgdgk9mu
- **Main Control Chip:** STM32F407VET6 (32-bit ARM-MCU)
- **Stepper Drivers:** Integrated TMC2209
- **Axes Supported:** 8

- **Input Voltage:** DC12-24V
- **Output Voltage:** DC12V (for fan), DC5V
- **Memory Storage Capacity:** 192 KB
- **RAM Memory Technology:** DDR2
- **Compatible Devices:** 3D Printers (Voron, Ender 3, Ender 3 V2, Ender 3 Pro) with Marlin 2.0.x, Klipper, or RRF firmware
- **Main Power Connector Type:** 24-Pin
- **Number of Ports:** 11
- **Package Dimensions:** 8.66 x 5.51 x 2.76 inches
- **Item Weight:** 12.3 ounces

## 10. WARRANTY AND SUPPORT

---

This product comes with a standard manufacturer's warranty. For specific warranty terms, duration, and conditions, please refer to the documentation provided with your purchase or contact the seller directly. For technical support, troubleshooting assistance, or further inquiries, please reach out to YDuupxe customer service or visit their official support channels.