



Manuals.plus /

› USSKYBOY /

› USSKYBOY 023705 Lawn Sprinkler Irrigation Pump Repair Kit User Manual

## USSKYBOY 023705

# USSKYBOY 023705 Lawn Sprinkler Irrigation Pump Repair Kit User Manual

Model: 023705

## 1. INTRODUCTION

---

### 1.1 Product Overview

The USSKYBOY 023705 Lawn Sprinkler Irrigation Pump Repair Kit is designed to restore the functionality of your 2 HP lawn sprinkler irrigation pump. This kit provides essential components for direct replacement, ensuring efficient and safe operation of your sprinkler system.

### 1.2 Compatibility

This repair kit is compatible with the following 2 HP lawn sprinkler irrigation pump models:

- Star HSP20P1
- Do It Best HSPJ20P1
- Utilitech UTP20P1
- Zoeller 1333-006

# 023705 2 HP Lawn Sprinkler Irrigation Pump Repair Kit

- for Star HSP20P1
- for Do It Best HSPJ20P1
- for Utilitech UTP20P1
- for Zoeller 1333-006



Figure 1: Overview of the 023705 repair kit components and compatible pump models.

## 2. PACKAGE CONTENTS

The 023705 Lawn Sprinkler Irrigation Pump Repair Kit includes the following components:

- Impeller
- Diffuser
- Motor Shaft Seal (Mechanical Seal)
- Diffuser Gasket
- Pump Body Gasket

## PACKAGE INCLUDES

Kit Includes an impeller, diffuser, motor shaft seal, diffuser gasket and pump body gasket.

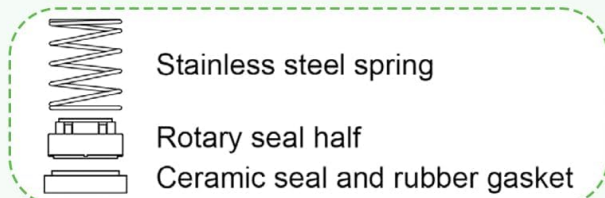

### Rotary Seal Assembly

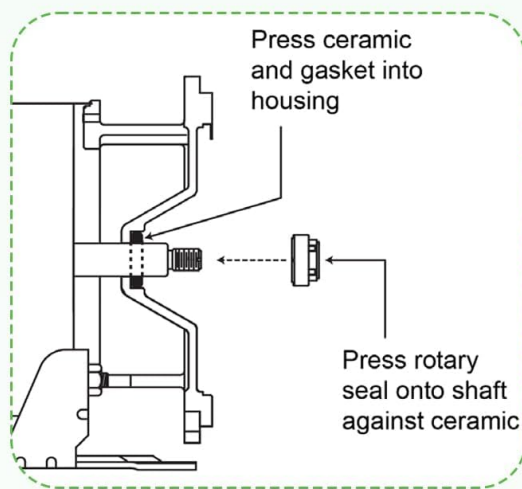

Figure 2: All components included in the repair kit, with a diagram of the rotary seal assembly.

## 3. SAFETY INFORMATION

Please read and understand all safety instructions before attempting any repair or maintenance on your pump. Failure to follow these instructions may result in personal injury or damage to equipment.

- **Disconnect Power:** Always ensure the pump's power supply is disconnected and locked out before beginning any work.
- **Wear Protective Gear:** Use appropriate personal protective equipment, such as safety glasses and gloves.
- **Drain System:** Completely drain the pump and associated plumbing to prevent water spillage and potential electrical hazards.
- **Consult Professional:** If you are unsure about any step, consult a qualified technician.
- **Handle Parts Carefully:** Some components may have sharp edges or delicate surfaces.

## 4. INSTALLATION INSTRUCTIONS

This repair kit is designed for direct replacement of original pump components. Follow these steps for proper installation.

## 4.1 Disassembly (General Steps)

1. Ensure the pump is disconnected from all power sources and the water supply is shut off.
2. Drain any remaining water from the pump and plumbing.
3. Carefully disassemble the pump housing to access the impeller, diffuser, and motor shaft seal. Note the orientation and position of each component during removal.
4. Remove the old impeller, diffuser, gaskets, and mechanical seal.

## 4.2 Component Identification and Placement

### DIRECT REPLACEMENT

The 2 HP Lawn Sprinkler Irrigation Pump Repair Kit is manufactured according to the original parts and can be used to directly replace the original parts to ensure the safe and efficient operation of your pump. This repair kit is easy to install and maintain, similar to your current sprinkler pump.

#### Installation Diagram

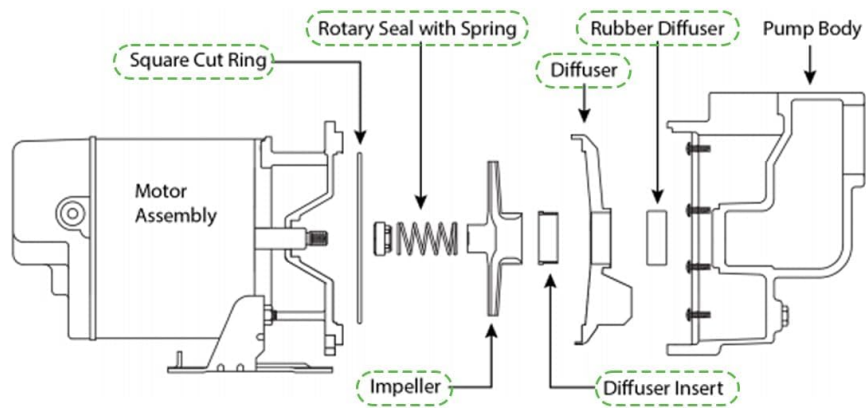

Figure 3: Installation diagram illustrating the position of the impeller, diffuser, and seals within the pump assembly.



Figure 4: The impeller and mechanical seal, key components for pump repair.





Figure 5: The mechanical seal assembly, crucial for preventing leaks.

### 4.3 Assembly Steps

1. **Install Mechanical Seal:** Carefully press the ceramic and gasket part of the mechanical seal into the pump housing. Then, press the rotary seal onto the motor shaft, ensuring it seats against the ceramic part. Refer to Figure 2 for the rotary seal assembly diagram.
2. **Place Diffuser Gasket:** Position the new diffuser gasket onto the pump body.
3. **Install Diffuser:** Place the diffuser over the gasket, aligning it correctly.
4. **Install Impeller:** Thread the new impeller onto the motor shaft, ensuring it is securely tightened.
5. **Place Pump Body Gasket:** Position the new pump body gasket.
6. **Reassemble Pump Housing:** Carefully reassemble the pump housing, ensuring all bolts are tightened evenly to prevent leaks.
7. **Reconnect Plumbing:** Reconnect all plumbing connections, ensuring they are secure and leak-free.
8. **Restore Power:** Once all connections are secure and checked, restore power to the pump.

## 5. OPERATION

---

After successful installation of the repair kit, your pump should operate as intended. Follow the original manufacturer's instructions for priming and operating your specific pump model.

- **Priming the Pump:** Ensure the pump is properly primed before its first operation after repair to prevent dry running and damage.
- **Check for Leaks:** Monitor all connections for any signs of leaks during initial operation.
- **Observe Performance:** Listen for unusual noises and observe water flow to confirm proper function.

## 6. MAINTENANCE AND CARE

---

The components in this repair kit are constructed from high-quality rubber and metal, designed for durability and resistance to rust and corrosion. Proper maintenance of your pump will extend its lifespan and ensure continued efficient operation.

## PREMIUM MATERIALS

The lawn sprinkler pump repair kit is constructed from high-quality rubber and metal, ensuring your pump continues to run efficiently throughout multiple and resists rust and corrosion due to constant water exposure.



RESISTS RUST AND CORROSION



STURDY AND DURABLE



PROFESSIONAL AND RELIABLE



WITH A LONGER SERVICE LIFE

Figure 6: Components made from premium materials for enhanced durability and resistance to corrosion.

- **Regular Inspection:** Periodically inspect the pump and connections for any signs of wear, damage, or leaks.
- **Winterization:** In colder climates, ensure your pump and irrigation system are properly winterized to prevent freeze damage.
- **Cleanliness:** Keep the pump area clean and free from debris that could interfere with its operation or ventilation.

## EXCELLENT PERFORMANCE

A Repair System for Residential and Applications Restore your residential or lawn and turf sprinkler system to full capacity with the Lawn Sprinkler Irrigation Pump Repair Kit.



Figure 7: The repair kit helps restore excellent performance to your residential or lawn and turf sprinkler system.

## 7. TROUBLESHOOTING

If you encounter issues after installing the repair kit, consider the following common troubleshooting steps:

Problem	Possible Cause	Solution
Pump not priming	Air leak in suction line; insufficient water in pump housing; clogged intake.	Check all suction line connections for tightness. Ensure pump housing is filled with water. Clear any obstructions.
Reduced water flow/pressure	Partially clogged impeller; air in system; incorrect impeller installation.	Inspect impeller for debris. Re-prime the pump. Verify impeller is correctly seated and tightened.
Water leaking from pump	Improperly installed mechanical seal or gaskets; damaged seal/gasket.	Re-check mechanical seal and gasket installation. Ensure all connections are tight. Replace any damaged components.
Unusual noise from pump	Bearing issue (not part of this kit); cavitation; foreign object in pump.	Ensure pump is properly primed. Inspect for foreign objects. If noise persists, consult a professional.

For issues not covered here, refer to your original pump's user manual or contact a qualified service technician.

## 8. SPECIFICATIONS

---

Key specifications for the USSKYBOY 023705 Lawn Sprinkler Irrigation Pump Repair Kit:

Feature	Detail
Model Number	023705
Brand	USSKYBOY
Material	High-quality Rubber and Metal
Item Weight	Approximately 14.9 ounces (0.42 kg)
Product Dimensions (Packaging)	6.57 x 6.57 x 2.52 inches (16.7 x 16.7 x 6.4 cm)
Compatibility	2 HP pumps: Star HSP20P1, Do It Best HSPJ20P1, Utilitech UTP20P1, Zoeller 1333-006

### 8.1 Component Dimensions

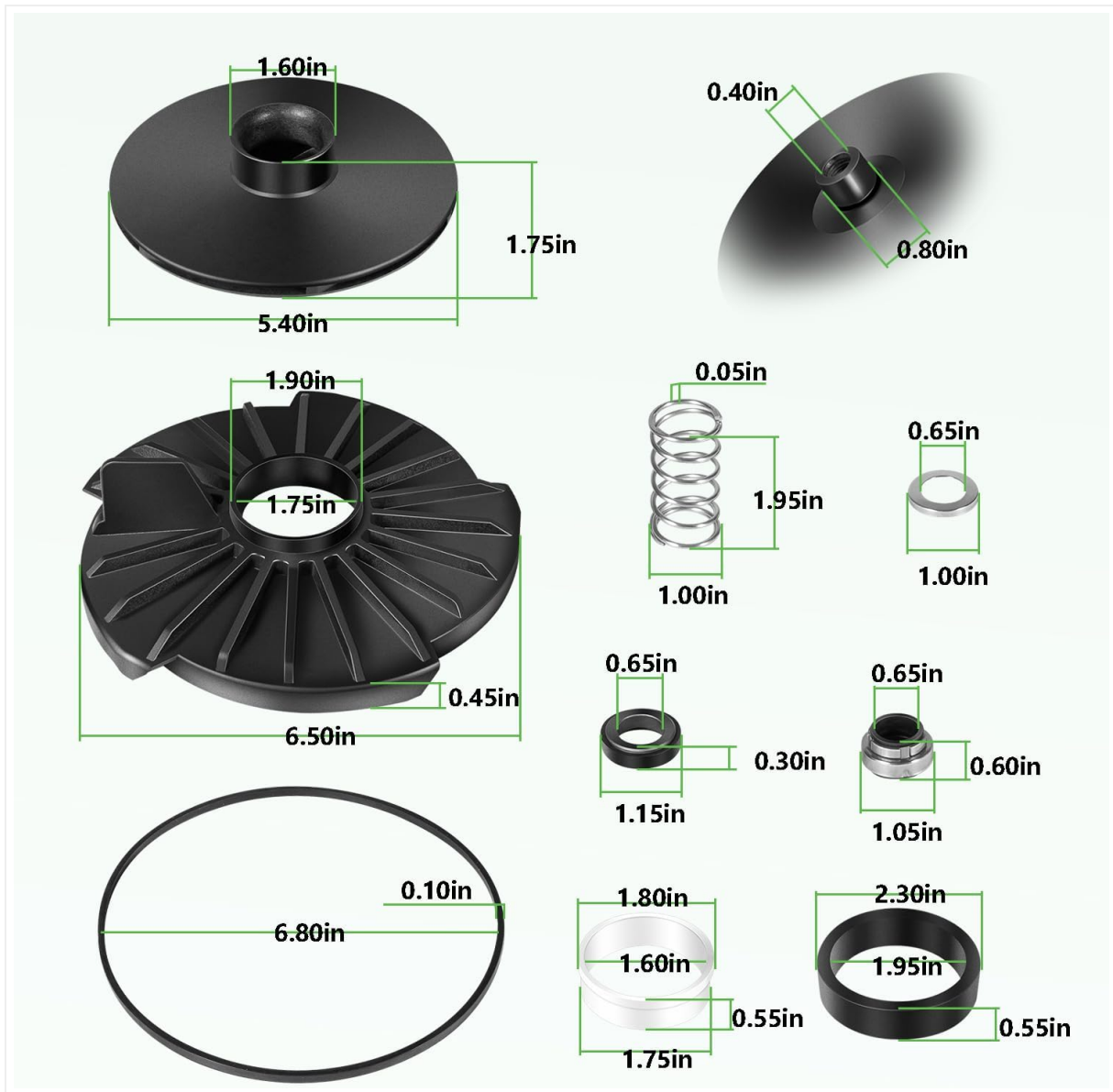

Figure 8: Detailed dimensions for the impeller, diffuser, and seal components.

## 9. WARRANTY AND CUSTOMER SUPPORT

For warranty information regarding your USSKYBOY 023705 Lawn Sprinkler Irrigation Pump Repair Kit, please refer to the purchase documentation or contact your retailer. Specific warranty terms may vary. For technical assistance or further inquiries, please contact USSKYBOY customer support through the contact information provided at the point of purchase or on the official USSKYBOY website.