



Manuals.plus /

› PrimeCables /

› PrimeCables Electric Adjustable Standing Desk (Model: Cab-PC-08485-WH) Instruction Manual

## PrimeCables Cab-PC-08485-WH

# PrimeCables Electric Adjustable Standing Desk (Model: Cab-PC-08485-WH) Instruction Manual

Brand: PrimeCables | Model: Cab-PC-08485-WH

[Introduction](#)   [Safety Information](#)   [Assembly Instructions](#)   [Operating Instructions](#)  
[Maintenance](#)   [Troubleshooting](#)   [Specifications](#)   [Warranty & Support](#)

## 1. INTRODUCTION

---

Thank you for choosing the PrimeCables Electric Adjustable Standing Desk. This manual provides essential information for the safe and efficient assembly, operation, and maintenance of your new desk. Designed for ergonomic comfort and versatility, this desk features a 3-memory controller, a spacious 47x24 inch splice board, and a robust heavy-duty steel frame, allowing for height adjustments from 28.3 to 46.1 inches. Please read this manual thoroughly before use and retain it for future reference.

## 2. SAFETY INFORMATION

---

For your safety and to prevent damage to the product, please observe the following:

- Always ensure the desk is within its specified height and weight limits. The maximum weight capacity is 110 lbs (50 kg).
- Do not force the desk to move if it encounters an obstacle. The desk is equipped with obstruction detection; if activated, remove the obstruction before resuming operation.
- Keep the work surface clear of objects that could fall and cause injury or damage during height adjustments.
- Use the anti-slip foot pads on uneven floors to maintain stability and prevent wobbling.
- Keep children and pets away from the desk during operation.
- Ensure all screws and connections are securely tightened before and after assembly. Regularly check for loose parts.
- Do not sit or stand on the desk frame.
- Avoid placing liquids directly on the control panel or near electrical components.

- If any unusual noise or malfunction occurs, immediately unplug the desk and contact customer support.

### 3. ASSEMBLY INSTRUCTIONS

---

Follow these steps carefully to assemble your PrimeCables Electric Adjustable Standing Desk. It is recommended to assemble the desk on a soft surface like a carpet or foam to prevent scratches.

#### 3.1 Unpacking and Component Check

Carefully unpack all components and lay them out. Verify that all parts listed in the packing list are present and undamaged. If any components are missing or damaged, please contact customer support.

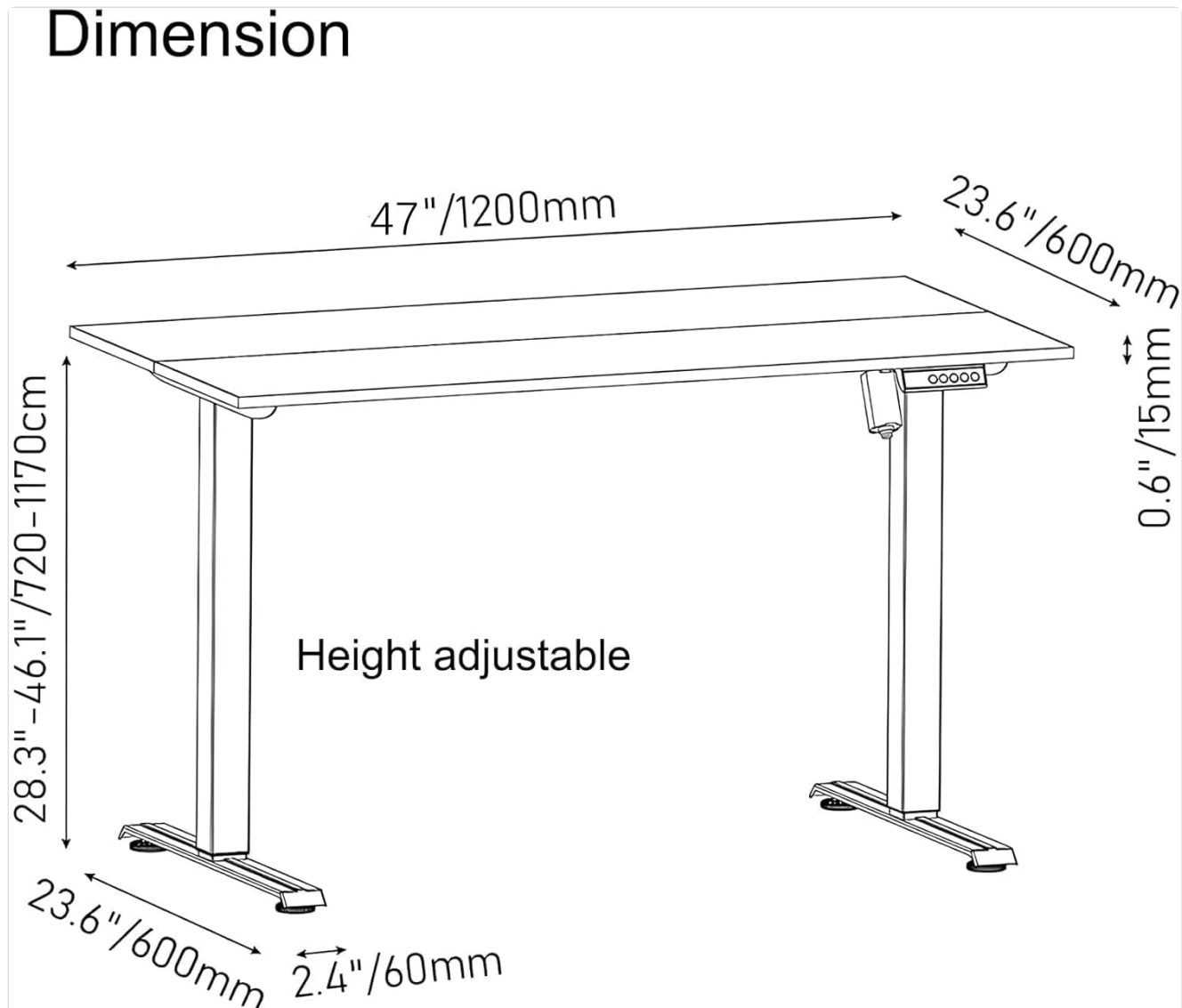

**Image 3.1:** All components of the PrimeCables standing desk laid out for assembly, including the desktop, legs, crossbar, motor, and control panel.

#### 3.2 Frame Assembly

Begin by assembling the desk frame. Attach the crossbar to the leg columns using the provided screws and tools. Ensure all connections are firm but do not fully tighten until all parts are aligned.

Your browser does not support the video tag.

**Video 3.2:** An animated guide demonstrating the step-by-step assembly of the Acrolix Standing Desk frame, including attaching legs and crossbars. This video is relevant for general frame assembly of electric standing desks.

Your browser does not support the video tag.

**Video 3.3:** An animated guide demonstrating the assembly process for the ERGOMAKER Adjustable Standing Desk, showing how to connect the frame components and motor. This video is relevant for general frame assembly of electric standing desks.

### 3.3 Attaching the Desktop

Once the frame is assembled, carefully place the splice board desktop onto the frame. Align the pre-drilled holes on the desktop with the mounting points on the frame. Secure the desktop using the provided screws. Ensure the splice board is correctly aligned to form a seamless surface.



**Image 3.4:** The PrimeCables Electric Adjustable Standing Desk featuring a two-piece splice board desktop, providing a spacious work surface.

### 3.4 Installing the Control Panel and Wiring

Mount the 3-memory controller to the underside of the desktop in the designated area. Connect the motor and control panel cables according to the instructions. Use cable management clips (if provided) to keep wires tidy and prevent entanglement.



## Controller Touch Screen



**Image 3.5:** A close-up view of the 5-button control panel with 3 memory presets and a digital display, mounted on the underside of the desk.

Your browser does not support the video tag.

**Video 3.6:** A short video showcasing the features of IMGadgets Electric Standing Desks, including the control panel and height adjustment. This video is relevant for understanding the control panel and its functions.

## 4. OPERATING INSTRUCTIONS

---

Your PrimeCables Electric Adjustable Standing Desk is designed for ease of use. Familiarize yourself with the control panel functions.

### 4.1 Basic Height Adjustment

- **Up Adjustment:** Press and hold the "Up" arrow button (▲) to raise the desk to your desired height. The real-time height will be displayed on the digital screen.
- **Down Adjustment:** Press and hold the "Down" arrow button (▼) to lower the desk to your desired height.
- Release the button once the desired height is reached. The desk has a lifting speed of 18mm/s for smooth transitions.



## Controller Touch Screen



Image 4.1: The 5-button control panel with up/down arrows and memory presets, showing the digital height display.

### 4.2 Memory Presets

The control panel features 3 memory presets (1, 2, 3) to save and recall your preferred sitting and standing heights.

- **To Save a Height:** Adjust the desk to your desired height. Press the "M" button, then press one of the number buttons (1, 2, or 3) within 3 seconds. The display will show "S-" followed by the number, indicating the height is saved.
- **To Recall a Saved Height:** Simply press the corresponding number button (1, 2, or 3). The desk will automatically move to the saved height.

### 4.3 Obstruction Detection

The desk is equipped with an obstruction detection system. If the desk encounters an obstacle during adjustment, it will stop and retract slightly to prevent damage. Remove the obstruction before attempting to adjust the height again.

## 5. MAINTENANCE

Regular maintenance ensures the longevity and optimal performance of your standing desk.

- **Cleaning:** Wipe the desktop and frame with a soft, damp cloth. Avoid harsh chemicals or abrasive cleaners that could damage the finish.

- **Cable Management:** Periodically check that all cables are securely routed and not pinched or tangled.
- **Screw Tightness:** Every few months, check all screws and bolts to ensure they are tight. Retighten if necessary to maintain stability.
- **Weight Distribution:** Distribute weight evenly across the desktop to prevent strain on the lifting mechanism.

## 6. TROUBLESHOOTING

---

If you encounter any issues with your desk, refer to the following common troubleshooting steps:

| Problem                                     | Possible Cause   | Solution   |
|---|--|--|
| Desk does not move.                         | Power cable disconnected, motor error, overload.       | Check power connections. Reduce weight on the desk. Perform a reset (see below).       |
| Desk moves unevenly or makes unusual noise. | Loose screws, uneven weight distribution, motor issue. | Check and tighten all screws. Redistribute weight. Contact support if issue persists.  |
| Digital display shows an error code.        | Specific error detected by the control system.         | Refer to the specific error code in the full manual (if available) or perform a reset. |
| Obstruction detection activates frequently. | Obstacles in the path of movement, sensitive setting.  | Ensure clear path for desk movement. Check if any cables are interfering.              |

### 6.1 Reset Procedure

If the desk is not functioning correctly, a reset may resolve the issue:

1. Press and hold the "Up" (▲) and "Down" (▼) arrow buttons simultaneously for 5 seconds.
2. Release the buttons when the indicator light turns red (or as per specific model instructions) to enter reset mode.
3. The tabletop will automatically lower to its lowest position, then bounce back slightly (3-5 mm).
4. The indicator light will turn blue, indicating the reset procedure is complete.

Your browser does not support the video tag.

**Video 6.1:** An animated guide demonstrating the reset procedure for an Acrolix Standing Desk, which is a common procedure for many electric standing desks. This video shows pressing up and down buttons simultaneously to initiate the reset.

## 7. SPECIFICATIONS

---

| <b>Feature</b>                 | <b>Detail</b>   |
|--------------------------------|---|
| <b>Brand</b>                   | PrimeCables   |
| <b>Model Number</b>            | Cab-PC-08485-WH   |
| <b>Product Dimensions</b>      | 120 x 60 x 117 cm (47 x 24 x 46.1 inches)   |
| <b>Height Adjustable Range</b> | 28.3" to 46.1" (72 cm to 117 cm)  |
| <b>Item Weight</b>             | 20.5 kg (45.2 lbs)  |
| <b>Material</b>                | Alloy Steel frame, Wood top   |
| <b>Color</b>                   | White   |
| <b>Special Features</b>        | Adjustable Height, Adjustable foot pads, Electric, Ergonomic, Splice Board, 3-Memory Controller, Obstruction Detection, Dual-Stage Lift System, Whisper-quiet dual motors ( $\leq 50$ dB) |
| <b>Weight Capacity</b>         | 110 lbs (50 kg)   |
| <b>Lifting Speed</b>           | 18mm/s  |

## **Sturdy Construction**

Enough to fully loaded office and game equipment up to 50kg/110lbs.



**Image 7.1:** A detailed diagram showing the dimensions and adjustable height range of the PrimeCables Electric Adjustable Standing Desk.

## **8. WARRANTY & SUPPORT**

---

PrimeCables is committed to providing high-quality products. For warranty information, technical support, or any questions regarding your Electric Adjustable Standing Desk, please refer to the contact information provided with your purchase documentation or visit the official PrimeCables website. Please have your model number (Cab-PC-08485-WH) ready when contacting support.