

HOROX 80H

HOROX 80mm Aperture 500mm Refractor Telescope User Manual

Model: 80H | Brand: HOROX

INTRODUCTION

Thank you for choosing the HOROX 80mm Aperture 500mm Refractor Telescope. This manual provides detailed instructions for the assembly, operation, maintenance, and troubleshooting of your new telescope. Please read this manual carefully before use to ensure proper setup and optimal viewing experience. Keep this manual for future reference.

PACKAGE CONTENTS

Verify that all items listed below are present in your package:

- Telescope Optical Tube (80mm Aperture, 500mm Focal Length)
- Adjustable Tripod
- K20mm Eyepiece (25x Magnification)
- K9mm Eyepiece (55x Magnification)
- Diagonal Prism
- Finderscope
- Phone Adapter
- Accessory Tray
- Backpack for storage and transport
- Instruction Manual



Figure 1: All components included in the HOROX Telescope package.

SETUP INSTRUCTIONS

Follow these steps to assemble your telescope:

1. Assemble the Tripod

1. Unfold the tripod legs and extend them to your desired height. Ensure the tripod is stable on a flat surface.
2. Attach the accessory tray to the center brace of the tripod.

MORE STABLE TRIPOD

High-quality 1.1 in thickened aluminum alloy for enhanced stability.



Figure 2: The stable, adjustable tripod.

2. Attach the Telescope Optical Tube

1. Locate the mounting screw on the tripod head.
2. Align the telescope optical tube with the tripod head and secure it using the mounting screw. Ensure it is firmly attached but do not overtighten.

3. Install the Finderscope

1. Slide the finderscope into its bracket on the main telescope tube.
2. Tighten the small screws on the bracket to hold the finderscope in place.



Figure 3: Finderscope attachment.

4. Insert the Diagonal Prism

1. Remove the dust cap from the focuser tube.
2. Insert the diagonal prism into the focuser tube and secure it with the small thumbscrew. The diagonal prism provides a more comfortable viewing angle.

5. Insert an Eyepiece

1. Select either the K20mm or K9mm eyepiece. The K20mm eyepiece provides lower magnification and a wider field of view, ideal for locating objects. The K9mm eyepiece offers higher magnification for detailed observation.
2. Insert the chosen eyepiece into the diagonal prism and secure it with the thumbscrew.

MAGNIFICATION FIELD OF VISION

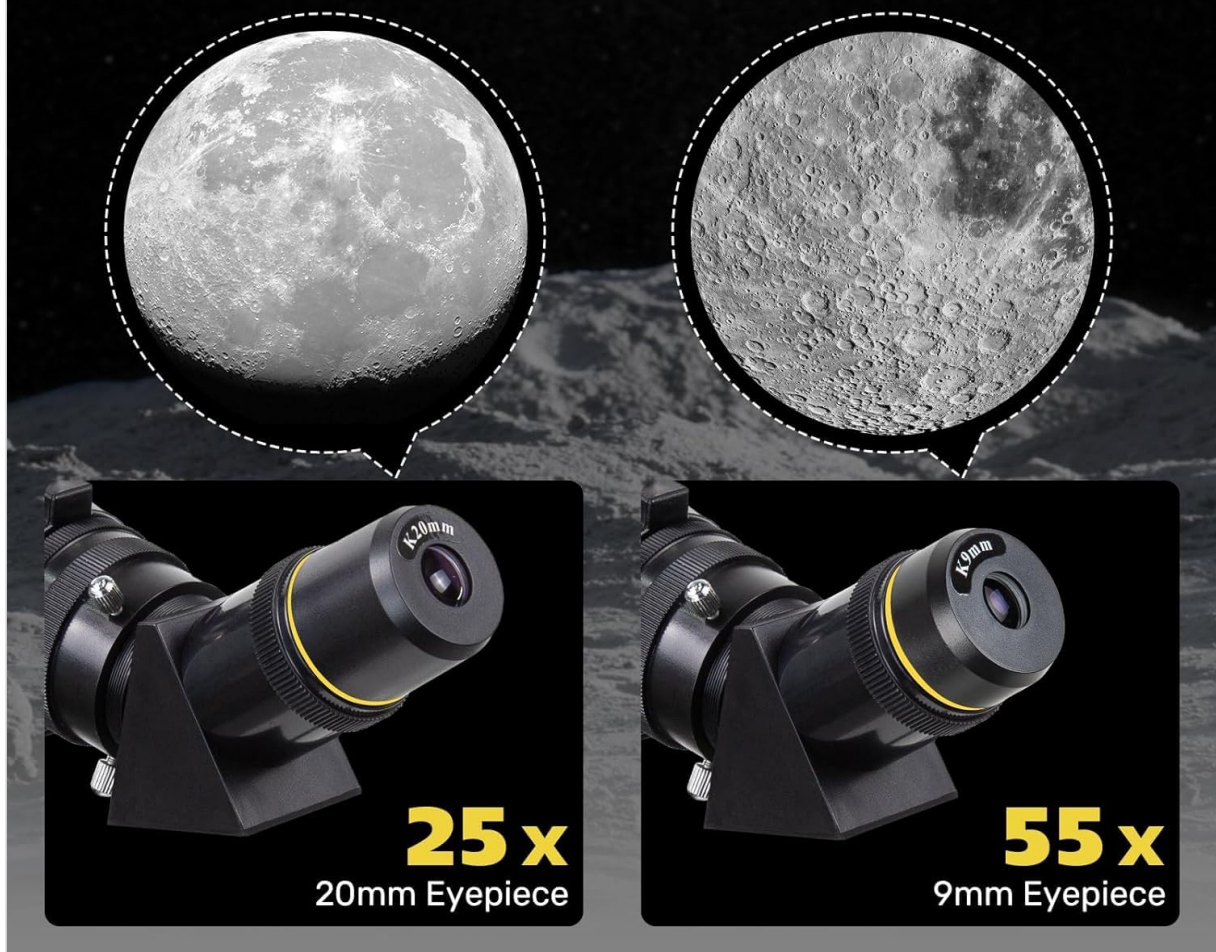

Figure 4: K20mm and K9mm eyepieces.

6. Attach Phone Adapter (Optional)

1. Attach your smartphone to the phone adapter.
2. Mount the phone adapter with your phone onto the eyepiece. Adjust the phone's camera to align with the eyepiece for photography.



Figure 5: Phone adapter for capturing images.

OPERATING YOUR TELESCOPE

Focusing

Once an object is centered in your eyepiece, slowly turn the focus knob until the image is sharp and clear. For best results, start with the K20mm eyepiece for a wider field of view, then switch to the K9mm eyepiece for higher magnification and finer detail.

Using the Finderscope

The finderscope has a wider field of view than the main telescope, making it easier to locate objects. Look through the finderscope and center the desired object in its crosshairs. Once centered, the object should be visible in the main telescope's eyepiece.

Changing Magnification

To change magnification, simply remove the current eyepiece and insert a different one. Remember that higher magnification reduces the field of view and requires more precise focusing.

UP TO 51 IN ADJUSTABLE HEIGHT

3-Section Adjustable Design
for Customized Comfort

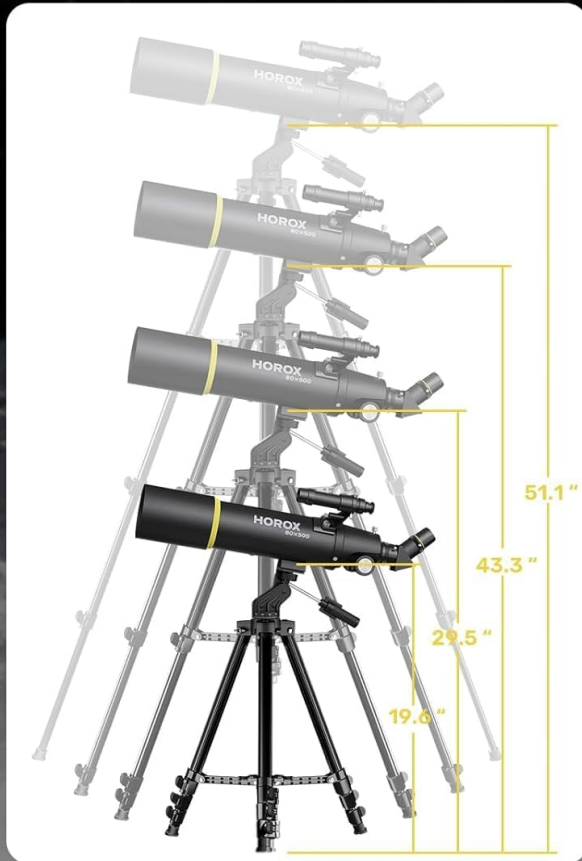

Multi-Angle Adjustment



Figure 6: Magnification comparison with K20mm and K9mm eyepieces.

Observing Celestial Objects

For astronomical observations, choose a dark location away from city lights. Allow your eyes to adjust to the darkness for at least 20 minutes. Start with the lowest magnification eyepiece (K20mm) to locate objects, then switch to higher magnification (K9mm) for detailed views of the Moon, planets, and brighter deep-sky objects.



**Easy
to Install**

**HOROX
80x500**

INSTRUCTION MANUAL
80 X 500mm Telescope
One Step Closer To The Galaxy

**USER MANUAL WITH A
DETAILED TUTORIAL**

**HOROX
SETUP TUTORIAL**

VIDEO TUTORIAL

Figure 7: Stargazing with the HOROX telescope.

Observing Terrestrial Objects

Your telescope can also be used for terrestrial viewing (observing objects on Earth). Note that the diagonal prism will correct the image vertically but may still show a horizontally inverted image. This is normal for astronomical telescopes and does not affect viewing quality.



Figure 8: Terrestrial viewing with image correction.

MAINTENANCE AND CARE

- **Cleaning Lenses:** Use a soft, lint-free cloth specifically designed for optical lenses. Breathe lightly on the lens to fog it, then gently wipe in a circular motion. Avoid touching the lens surfaces with your fingers.
- **Dust Caps:** Always keep the dust caps on the telescope's objective lens and eyepieces when not in use to prevent dust accumulation.
- **Storage:** Store the telescope in a dry, cool place, preferably in its provided backpack, to protect it from dust and moisture.
- **Avoid Extreme Temperatures:** Do not expose the telescope to sudden or extreme temperature changes, as this can cause condensation and potentially damage optical components.

TROUBLESHOOTING

Problem	Possible Cause	Solution
Image is blurry or out of focus.	Focus knob not adjusted correctly; eyepiece not fully inserted.	Adjust the focus knob slowly. Ensure the eyepiece is fully inserted and secured.
Cannot find objects.	Finderscope not aligned; starting with too high magnification.	Align the finderscope with the main telescope. Start with the K20mm eyepiece to locate objects.
Image is dim or dark.	Light pollution; high magnification in poor conditions; dirty lenses.	Move to a darker viewing location. Use lower magnification. Clean lenses carefully.
Image is upside down or reversed.	Normal for astronomical viewing; diagonal prism not used for terrestrial viewing.	For astronomical viewing, this is normal. For terrestrial viewing, ensure the diagonal prism is correctly installed.

Problem	Possible Cause	Solution
Tripod is unstable.	Legs not fully extended or locked; uneven surface.	Ensure tripod legs are fully extended and locked. Place on a firm, level surface.

PRODUCT SPECIFICATIONS

Model Number	80H
Optical Design	Refractor
Aperture	80mm
Focal Length	500mm
Eyepieces Included	K20mm (25x), K9mm (55x)
Finderscope	Reflex
Mount Type	Altazimuth Mount
Tripod Material	High-quality aluminum alloy
Adjustable Tripod Height	Up to 51 inches (approx. 130 cm)
Product Dimensions	44 x 13.02 x 31 cm (packaged)
Item Weight	3.12 kg

WARRANTY AND CUSTOMER SUPPORT

HOROX provides a lifetime warranty for this telescope upon registration. Our team of technical experts is available to provide exceptional service and support for any inquiries or issues you may encounter. For support, please contact us at: info@horox.co
Please include your model number (80H) and a detailed description of your issue when contacting support.