

[Manuals.plus](#) /

> [auto paw](#) /

> User Manual: auto paw Pro 1 Series Roof Rack System

auto paw Pro 1 Series Roof Rack System

User Manual: auto paw Pro 1 Series Roof Rack System

Model: For Peugeot 207 Sw 2002-2008

INTRODUCTION

The auto paw Pro 1 Series Cross Bar System is designed for vehicles with raised roof rails, specifically compatible with Peugeot 207 Sw models from 2002-2008. This system provides a secure and versatile platform for transporting various cargo, freeing up interior space. Its aerodynamic design aims to minimize wind noise and impact on fuel consumption, ensuring a smooth and efficient journey.

This manual provides essential information for the safe and correct installation, operation, and maintenance of your auto paw roof rack system.

SAFETY INFORMATION

- Always ensure the roof rack and any attached cargo are securely fastened before driving.
- Do not exceed the maximum load capacity of 100 kg (220 lbs) for the roof rack system, or the maximum load capacity specified by your vehicle manufacturer, whichever is lower.
- Distribute cargo evenly on the roof rack to maintain vehicle stability.
- Check the tightness of all bolts and fasteners regularly, especially after the first few miles of driving and before long trips.
- Be aware of increased vehicle height and potential changes in handling when carrying cargo on the roof.
- Avoid automatic car washes with the roof rack installed.

PACKAGE CONTENTS

Please verify that all components are present in the box before beginning installation:

- 2 x Aluminium Profiles (Cross Bars)
- 4 x Head Brackets
- 2 x Metal Keys

- 2 x Allen Wrenches
- 1 x User Manual (this document)
- 2 x Suppositories (likely referring to rubber pads or end caps)
- Mounting Bolts
- 2 x Rubber Strips (VGS rubber strip)

PRODUCT SPECIFICATION



Image: All components included in the auto paw Pro 1 Series Roof Rack System package, including cross bars, keys, Allen wrench, rubber strips, and user guide.

SETUP AND INSTALLATION

The auto paw Pro 1 Series Cross Bar System is designed for straightforward self-assembly without requiring specialized tools or technical support. All necessary mounting tools are included with the product.

1. **Prepare Your Vehicle:** Ensure your vehicle's raised roof rails are clean and free from debris.

2. **Assemble the Cross Bars:** The cross bars come largely pre-assembled. Attach the head brackets to the aluminum profiles if not already done. Ensure the "PAW" logo on the head brackets faces outwards.
3. **Position the Cross Bars:** Carefully place the assembled cross bars onto your vehicle's raised roof rails. Adjust their position to be parallel and evenly spaced, typically one towards the front and one towards the rear of the roof.
4. **Secure the Head Brackets:** The head brackets feature an easy-open lid mechanism. Open the lid to access the mounting bolts. Use the provided Allen wrench to tighten the mounting bolts, securing the cross bars firmly to the raised rails. Ensure a snug fit, but do not overtighten.
5. **Lock the System:** Each head bracket is equipped with a metal lock system for added security. Use the provided metal keys to lock the head brackets once installed. This prevents unauthorized removal of the cross bars.
6. **Install VGS Rubber Strips:** Insert the VGS rubber strips into the T-channels on the top of the aluminum profiles. These strips help reduce wind drag and noise, and provide protection for your roof rack and cargo.
7. **Final Check:** After installation, gently shake the cross bars to ensure they are securely mounted and do not wobble. Double-check all bolts and locks.

Pro 1

RAISED RAILS



Heavy Duty Durable Construction

| Lightweight





Easy Open Lid



Aero Aluminum



Quick Access T-Slot



Pre-assembled















Image: Key features highlighting the pre-assembled nature, easy-open lid, and quick access T-slot for installation.





Image: A close-up view of the integrated metal lock system on the auto paw roof rack, showing the key inserted.



Image: The auto paw roof rack system securely installed on a vehicle's raised roof rails, viewed from above.

OPERATING AND USAGE

Once installed, your auto paw Pro 1 Series Roof Rack System provides a robust platform for carrying a wide range of accessories and cargo. The T-channels on the profiles allow for easy mounting of various attachments.

Compatible Accessories and Usage Purposes:

- **Camping Equipment:** Transport tents, sleeping bags, and other gear.
- **Vehicle Tent Systems:** Ideal for mounting rooftop tents.
- **Roof Rack Box Cabins:** Securely attach cargo boxes of various sizes.
- **Bicycle Carrier Systems:** Mount bike racks for transporting bicycles.
- **Snowboards, Ski Carriers:** Attach specialized carriers for winter sports equipment.
- **Water Sports Equipment:** Perfectly suited for the installation of canoes, kayaks, and paddleboards.

The aerodynamic design, including the VGS rubber strip, minimizes wind noise and drag, contributing to better fuel efficiency during travel.



Image: A vehicle demonstrating the use of the auto paw roof rack system with an attached cargo basket, illustrating its versatility for carrying various items.



All bars include the **VGS rubber strip** which has been designed to reduce wind drag and noise as well as providing added protection for your roof racks and load.

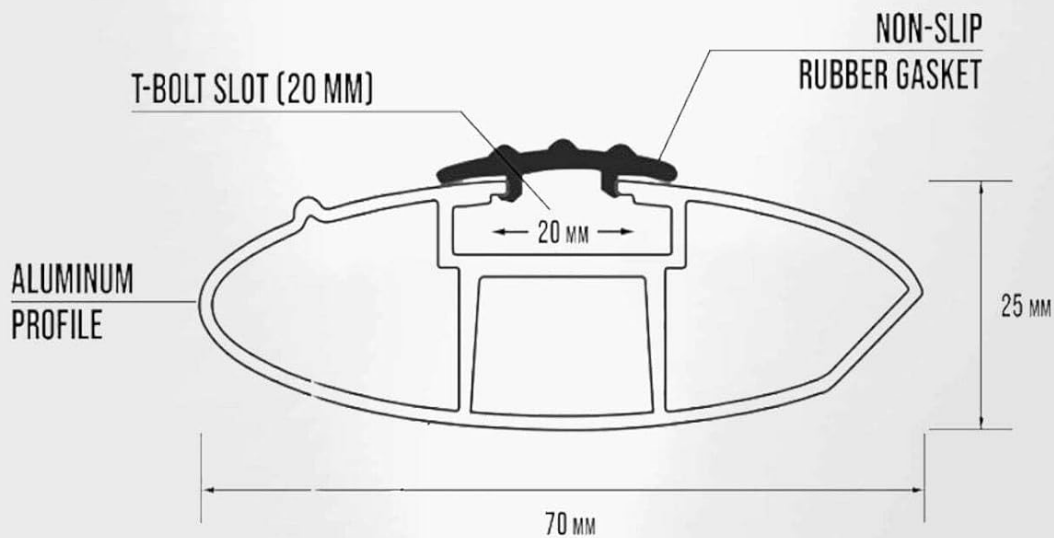

Image: A detailed cross-section diagram of the aluminum profile, showing the integrated VGS rubber strip designed to reduce wind noise and provide protection, along with profile dimensions.

FIT FOR MOST CROSSBARS WITH T-TRACK

Confirm the Dimension of the Crossbars
T-track Before Purchase



Image: A diagram illustrating the dimensions of the T-bolt slot (20mm / 0.81 inches) on the auto paw crossbars, confirming compatibility with standard T-track accessories.

MAINTENANCE

Regular maintenance will ensure the longevity and safe operation of your auto paw roof rack system.

- **Regular Cleaning:** Clean the aluminum profiles and plastic components with mild soap and water. Avoid abrasive cleaners or solvents that could damage the finish.
- **Check Fasteners:** Periodically inspect all mounting bolts and fasteners for tightness. Vibrations during driving can cause them to loosen over time. Re-tighten as necessary using the provided Allen wrench.
- **Inspect Rubber Strips:** Check the VGS rubber strips for any signs of wear, cracking, or damage. Replace if necessary to maintain aerodynamic performance and protection.
- **Lubricate Locks:** If the lock mechanism becomes stiff, apply a small amount of graphite lubricant or a silicone-based spray to the keyhole.

- **Seasonal Removal:** If the roof rack is not in use for extended periods, consider removing it to reduce wear and tear and potentially improve fuel efficiency. Store in a dry, protected area.

TROUBLESHOOTING

Problem	Possible Cause	Solution
Excessive wind noise	Improper installation; Missing or damaged VGS rubber strips; Cargo not aerodynamically loaded.	Ensure cross bars are securely and evenly installed. Check and replace VGS rubber strips if damaged. Re-position or secure cargo.
Cross bars feel loose	Mounting bolts are not sufficiently tightened.	Re-tighten all mounting bolts using the provided Allen wrench. Ensure a firm, secure fit.
Difficulty attaching accessories to T-channel	Incorrect T-bolt size; Obstruction in the channel.	Ensure accessories use T-bolts compatible with a 20mm slot. Clear any debris from the T-channel.
Key stuck or lock mechanism stiff	Dirt/debris in lock; Lack of lubrication.	Apply a small amount of graphite lubricant or silicone spray into the keyhole. Gently work the key in and out.

SPECIFICATIONS

- **Product Name:** auto paw Pro 1 Series Roof Rack System
- **Model Compatibility:** Peugeot 207 Sw (2002-2008) with raised roof rails
- **Material:** High-grade Aluminum Profiles, Durable Plastic Head Brackets
- **Color:** Silver (Aluminum Profiles), Black (Head Brackets)
- **Maximum Load Capacity:** 100 kg (220 lbs) - *Note: Always adhere to your vehicle's manufacturer-specified roof load limit if lower.*
- **Item Weight:** Approximately 4 kg (8.82 lbs)
- **Profile Dimensions (Approximate):**
 - Width: 70 mm
 - Height: 25 mm
- **T-Slot Dimension:** 20 mm (0.81 inches)
- **Security:** Integrated Metal Lock System
- **Aerodynamics:** Features VGS rubber strip for reduced wind noise and drag.



Image: The auto paw Pro 1 Series Roof Rack System, showcasing the two aluminum cross bars with black end caps.

WARRANTY AND SUPPORT

For any questions, concerns, or support regarding your auto paw Pro 1 Series Roof Rack System, please contact the seller or manufacturer, Kayi Teknik, through your purchase platform. Please have your product model and purchase date available when contacting support.

© 2023 auto paw. All rights reserved.

This manual is for informational purposes only. Specifications are subject to change without notice.