



Manuals.plus /

› DVNXDPXJ /

› MSQ-80 Toroidal Current Transformer User Manual

DVNXDPXJ MSQ-80

MSQ-80 Series Toroidal Current Transformer User Manual

Model: MSQ-80 | Brand: DVNXDPXJ

1. INTRODUCTION

The DVNXDPXJ MSQ-80 series toroidal current transformers are precision instruments designed for accurate current measurement, control, display, and protection of electrical equipment. These transformers are suitable for use in AC circuits with a rated voltage below 660V and a frequency range of 50-60Hz. They can also be integrated with mining transformers for various industrial applications.

This manual provides essential information regarding the features, applications, installation, operation, and maintenance of your MSQ-80 current transformer to ensure safe and efficient use.

2. KEY FEATURES

- **Safety:** Designed with safety in mind for reliable operation.
- **Ease of Installation:** Portable and straightforward to install.
- **Versatile Design:** Features a wide inner window, accommodating large cables or busbars.
- **Adaptability:** Available in a wide range of sizes to suit various existing electrical installations.



Figure 2.1: Front view of the MSQ-80 Toroidal Current Transformer, highlighting its robust design and wide inner aperture.

3. APPLICATIONS

The MSQ-80 current transformer is suitable for a variety of applications, including but not limited to:

1. Current measurement, monitoring, and protection of electrical circuits and equipment.
2. Current and power measurement for motors, lighting systems, air compressors, HVAC systems, and other automation control systems.
3. Integration into current, power, and energy monitoring devices.
4. Use in relay protection devices.

4. TECHNICAL SPECIFICATIONS

The following table outlines the general technical specifications for the MSQ series current transformers. Specific values may vary slightly depending on the exact model and current rating (e.g., 2000A, 5A variant).

Parameter	Value/Range
Primary Current Range	5A - 6000A
Secondary Current	5A or 1A
Standard Approval	IEC44-1, BS7626
Maximum Voltage	0.72/3KV
Frequency	50/60 Hz
Rated Burden (Specified Load)	2.5VA / 5VA / 10VA / 15VA
Accuracy Class	0.5, 1.0
Short-time Thermal Current (Ith)	60 * I _n (Rated Primary Current)
Rated Safety Factor	< 5

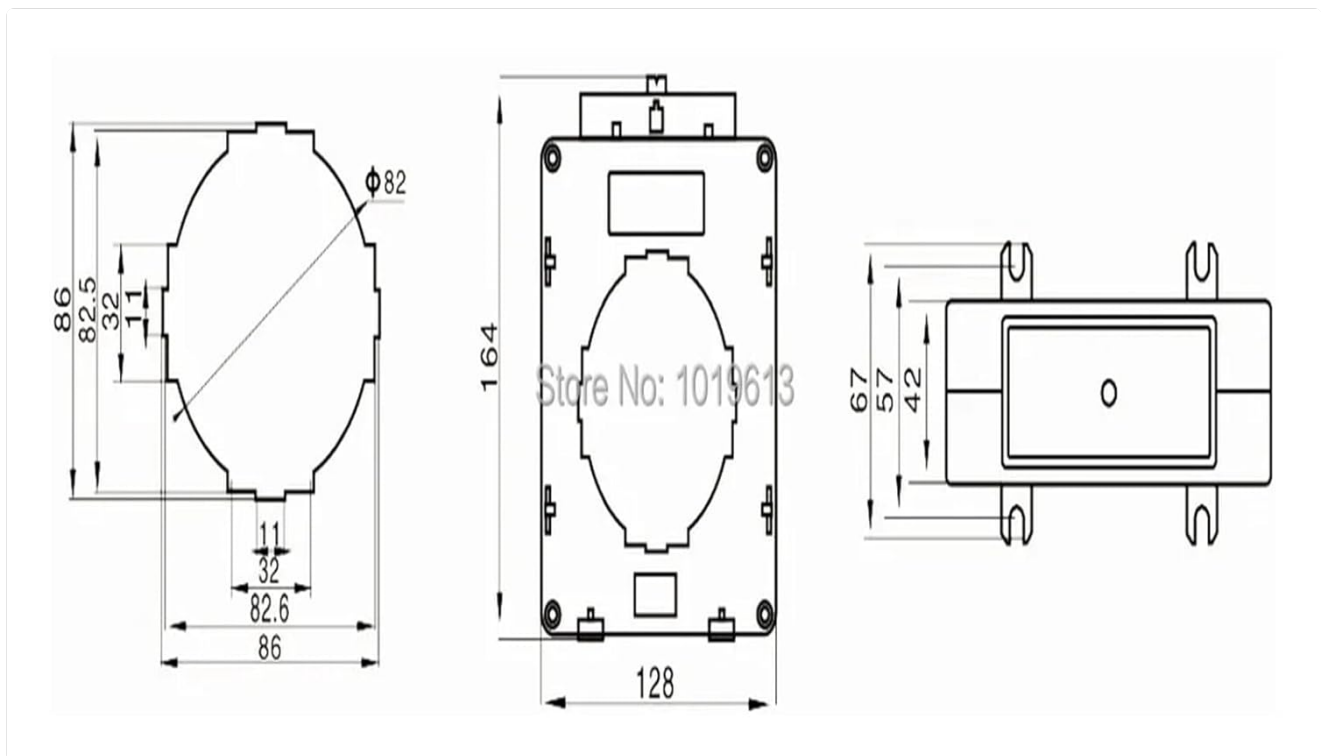

Figure 4.1: Detailed dimensional drawing of the MSQ-80 series current transformer, showing key measurements for installation planning.

5. INSTALLATION AND SETUP

Proper installation is crucial for the accurate and safe operation of the MSQ-80 current transformer. Always ensure power is disconnected before beginning any installation work.

5.1. Components Overview

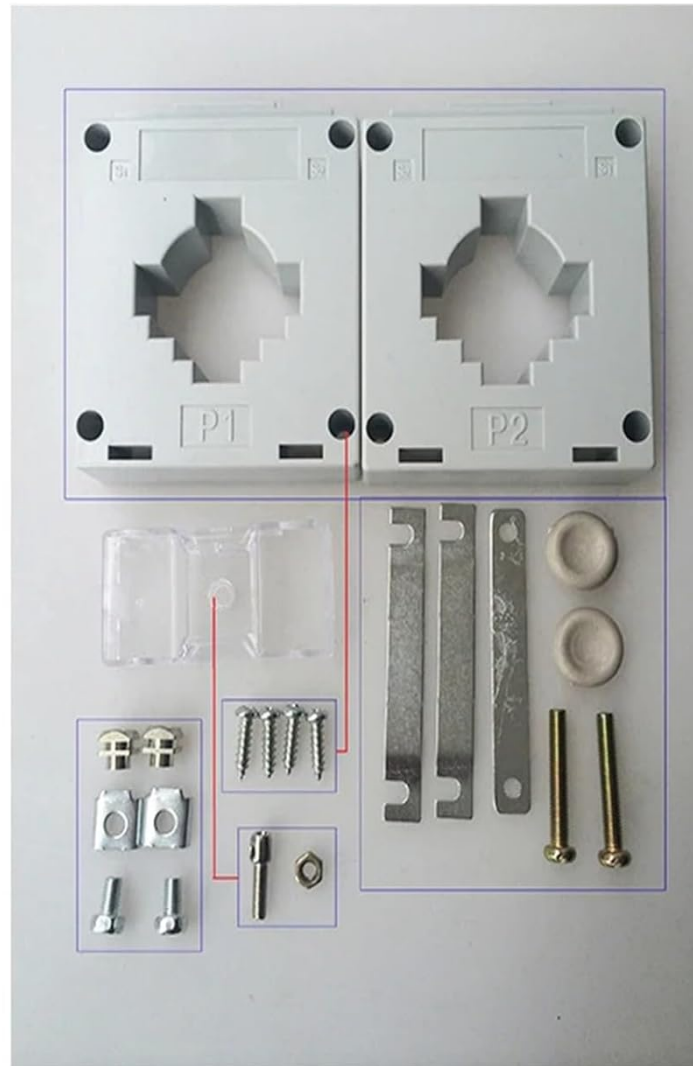

Figure 5.1: Overview of the MSQ-80 current transformer components, including the main body, terminal cover, and various mounting hardware (screws, brackets).

5.2. Mounting Instructions

1. **Safety First:** Ensure the main power supply to the circuit where the transformer will be installed is completely de-energized and locked out.
2. **Select Location:** Choose a mounting location that is stable, free from excessive vibration, moisture, and extreme temperatures. Ensure adequate clearance for wiring and maintenance.
3. **Secure Mounting:** Use the provided mounting hardware (screws and brackets) to securely fasten the current transformer to a panel or suitable surface. Refer to Figure 4.1 for dimensions and mounting points.
4. **Primary Conductor Installation:** Pass the primary conductor (cable or busbar) through the central aperture of the current transformer. Ensure the conductor is centered within the opening for optimal performance.
5. **Secondary Wiring:** Connect the secondary terminals (typically marked S1 and S2 or P1 and P2) to your measuring instrument (e.g., ammeter, power meter, relay) using appropriate gauge wiring. Observe polarity if specified by your measuring device.
6. **Terminal Cover:** Once wiring is complete, secure the transparent terminal cover over the secondary terminals to protect connections and prevent accidental contact.
7. **Grounding:** Ensure proper grounding of the current transformer as per local electrical codes and safety standards.

Note: Always consult a qualified electrician for installation if you are unsure about any steps.

6. OPERATION

The MSQ-80 current transformer operates by inducing a proportional secondary current from the primary current flowing through its aperture. It is a passive device and does not require external power for its core function.

- **Current Measurement:** Once installed, the primary current flowing through the transformer's window will induce a scaled-down current in the secondary winding. This secondary current is then measured by a connected ammeter or other compatible device.
- **Burden:** Ensure the connected measuring instrument's impedance (burden) does not exceed the rated burden of the current transformer. Exceeding the burden can lead to inaccurate readings and potential damage to the transformer.
- **Open Circuit Secondary:** *Never operate the current transformer with its secondary circuit open while primary current is flowing.* This can lead to dangerously high voltages across the secondary terminals, posing a severe safety hazard and potentially damaging the transformer. Always ensure the secondary circuit is connected to a load or short-circuited before applying primary current.

7. MAINTENANCE

The MSQ-80 current transformer is designed for long-term, reliable operation with minimal maintenance. However, periodic inspection is recommended to ensure continued performance and safety.

- **Visual Inspection:** Periodically inspect the transformer for any signs of physical damage, discoloration, or loose connections.
- **Cleaning:** If necessary, gently clean the exterior of the transformer with a dry, lint-free cloth. Do not use abrasive cleaners or solvents. Ensure the power is off before cleaning.
- **Connection Check:** Verify that all primary and secondary connections remain tight and secure. Loose connections can lead to inaccurate readings or overheating.
- **Environmental Conditions:** Ensure the operating environment remains within the specified temperature and humidity ranges to prevent premature aging or failure.

8. TROUBLESHOOTING

If you encounter issues with your MSQ-80 current transformer, consider the following common troubleshooting steps:

Problem	Possible Cause	Solution
No reading on connected meter.	No primary current. Loose or incorrect secondary wiring. Faulty measuring instrument. Open secondary circuit.	Verify primary circuit is energized and current is flowing. Check all secondary connections for tightness and correct polarity. Test the measuring instrument with a known source. Ensure secondary is connected to a load or short-circuited.
Inaccurate readings.	Incorrect CT ratio selected on meter. Excessive burden on secondary. Primary conductor not centered. External magnetic fields.	Verify the CT ratio setting on your meter matches the transformer's ratio. Ensure the connected load (burden) is within the transformer's specifications. Adjust the primary conductor position. Relocate the transformer away from strong magnetic fields if possible.
Transformer overheating.	Overcurrent in primary circuit. Short circuit in secondary winding. Excessive burden.	Verify primary current is within rated limits. Inspect secondary wiring for shorts. Reduce the burden on the secondary circuit.

If the problem persists after attempting these steps, contact qualified technical support.

9. WARRANTY AND SUPPORT

For information regarding the warranty period and terms for your DVNXDPXJ MSQ-80 current transformer, please refer to the product packaging or the official DVNXDPXJ website. For technical support, troubleshooting assistance beyond this manual, or spare parts inquiries, please contact DVNXDPXJ customer service through their official channels.

Please retain your purchase receipt for warranty claims.