

Banfluxion RC-210E

Banfluxion RC-210E Precision Metal Bench Lathe

USER INSTRUCTION MANUAL

Model: RC-210E | Brand: Banfluxion

1. INTRODUCTION

This manual provides essential information for the safe and efficient operation, maintenance, and troubleshooting of your Banfluxion RC-210E Precision Metal Bench Lathe. Please read this manual thoroughly before operating the machine to ensure proper usage and to prevent injury or damage.

1.1 Safety Information

Always prioritize safety when operating machinery. Wear appropriate personal protective equipment (PPE) including safety glasses, hearing protection, and suitable clothing. Ensure the work area is clean, well-lit, and free from obstructions. Disconnect power before performing any maintenance or adjustments.

2. PRODUCT OVERVIEW

The Banfluxion RC-210E is a versatile 8"x32" precision metal bench lathe featuring a 1100W brushless motor and variable speeds from 50-2500rpm. It is designed for various metalworking tasks including turning, threading, and polishing.

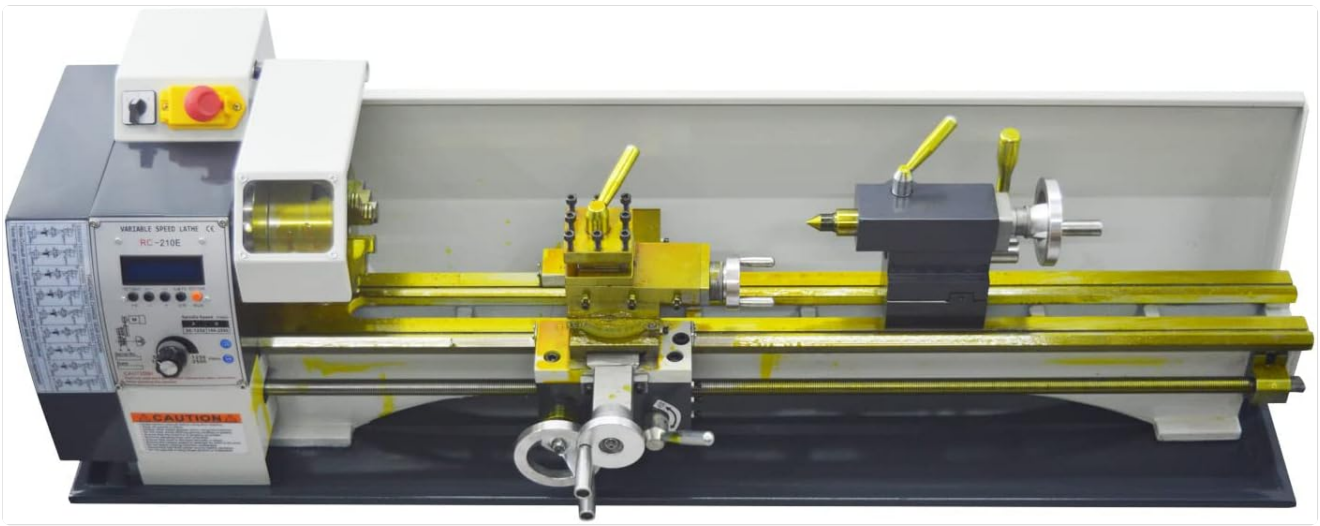
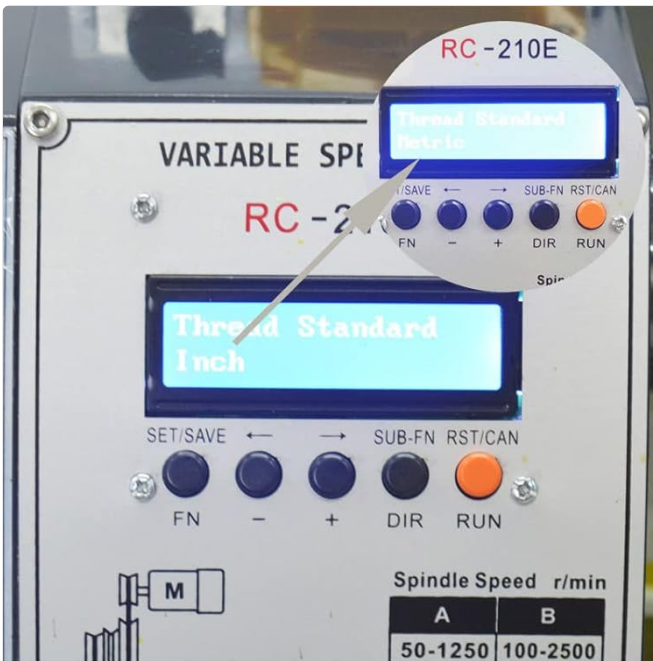

Figure 2.1: Overview of the Banfluxion RC-210E Precision Metal Bench Lathe.

2.1 Key Features

- **Thread Switch:** Automatic switching between metric and inch threads via the control panel, eliminating the need for manual gear changes.
- **Indexing Function:** DIR button on the control panel allows switching the turning tool direction and clearing the angle with one click.
- **Automatic Feed:** Achieves automatic feed in the X-axis direction with a range of 0.01mm-0.4mm.
- **Multiple Operation Modes:** Supports manual start, automatic start, and delay automatic start for turning operations.
- **Multifunctionality:** Suitable for metal turning, screw threading, internal and external thread cutting, wood turning, and polishing.



Metric & Imperial

Switching between metric and imperial is no longer required by changing gears! Only need to operate through the panel, save a lot of time!

Gearless Design

New gearless design! Brand new belt drive! Lower noise, no longer need to change gears to adjust the processing thread, only need to operate on the panel, processing efficiency/save greatly improved!

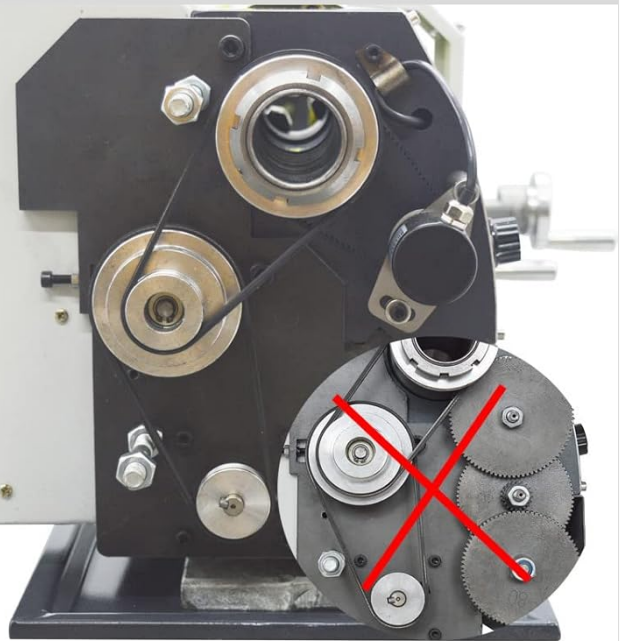
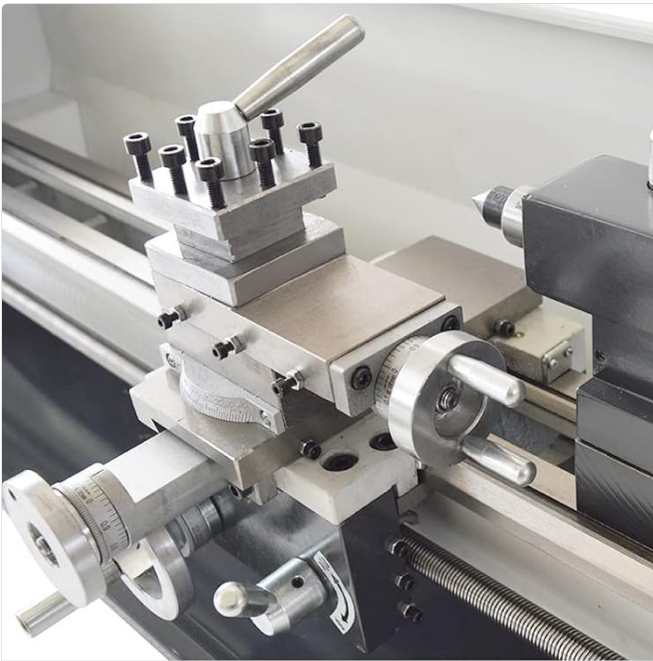

Figure 2.2: Control panel for thread selection and illustration of the gearless belt drive system.



V

4-way Tool Post

The adjustable 4-way tool post on the lathe allows you to easily change your cutting tools. The 8 screws allow you to better grip the tool and finish the machining efficiently

VI

Three Jaw Chuck

High-precision three-jaw chucks with 125mm clamping diameter are used to clamp square and round materials firmly, We also offer optional four-jaw chucks

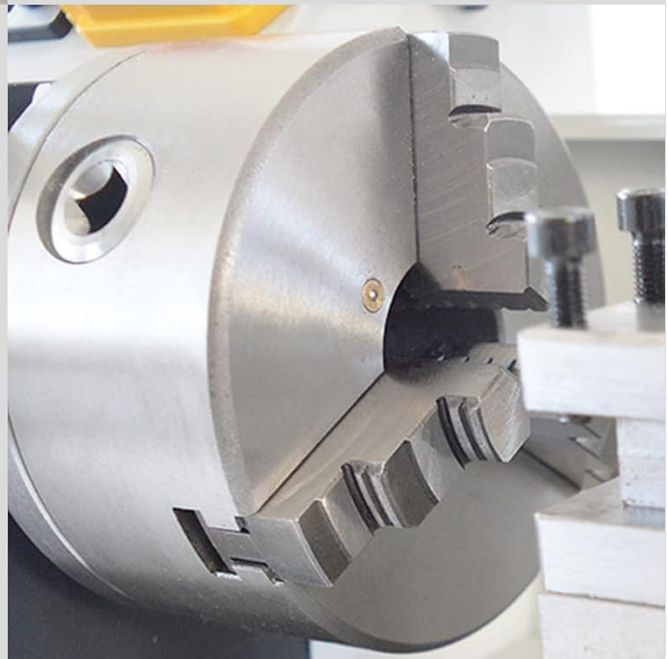
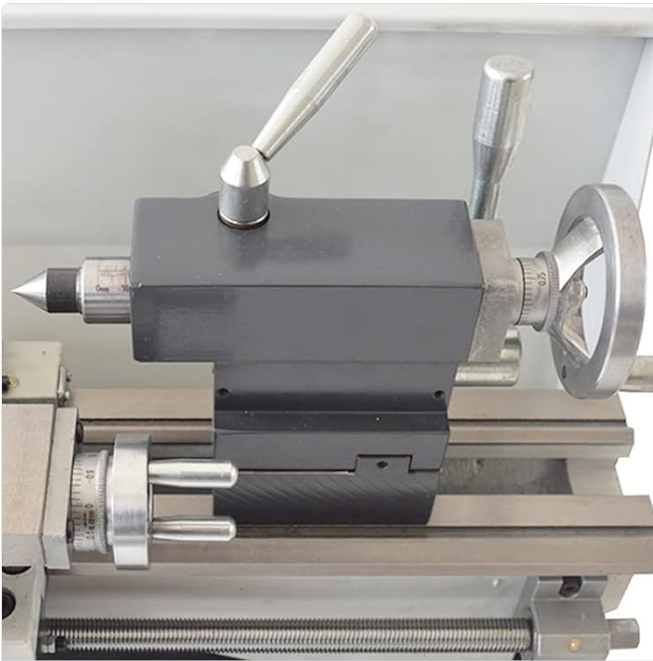

Figure 2.3: Details of the 4-way tool post and the high-precision three-jaw chuck.



VII

Accurate Tailstock

The tailstock is movable and fixed, with a maximum center distance of 31.5 inch at the far right. With the MT#2 taper in tailstock spindle, this lathe machine is capable of adjusting set screws for accurate operation.

VIII

Switch

Control panel above the design of forward and reverse switch and start & emergency stop switch, easy to operate, in case of emergency can immediately cut off the power supply, to ensure personal safety



Figure 2.4: The movable and fixed tailstock with MT#2 taper and the safety control switches.

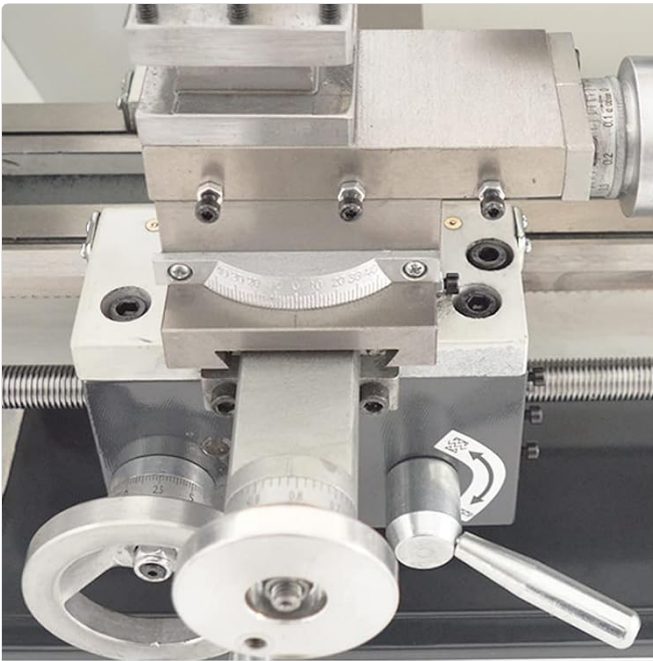

IX

Metric Scale

Precise metric scale are provided on the saddle handle, the tailstock handle and the movable center, allowing for more accurate and professional work.If you need the inch scale can be customized

X

Wide Application

This mini metal lathe is suitable for many processing tasks including turning, drilling, threa ding and cutting and so on.It can meet most of your DIY processing needs



Metal Turning



Screw Threading



Internal and External Thread



Turning and Polishing



Gyroscope Processing



Wood Turning



Turned Screw



Slot Turning



Taper Turning

Figure 2.5: Precise metric scales for accurate work and examples of lathe applications.

3. SPECIFICATIONS

Product Parameters

Model:	RC-210E
Voltage:	AC110V 50/60Hz(Brushless Motor)
Power:	1100W(1.5HP)
Length of center:	31.50"(800mm)
Swing Over Bed:	8.27"(210mm)
Rotary diameter of tool rest:	5.51"(140mm)
Spindle bore:	1.50"(38mm)
Diameter of chuck:	4.92"(125mm)
Width of lathe bed:	3.94"(100mm)
Thread standard:	Metric/imperial/customized
Turning delay start time:	1s-30s
Number of Spindle Speeds:	Infinitely variable speeds
Range of Inch Threads:	10-44T.P.I
Range of metric threads:	0.5mm-3mm
Spindle taper:	MT5
Knife rest labour:	Horizontal four-station
Spindle rotation speed:	50-2500rpm
Precision of the spindle:	0.01mm
Automatic feed range:	0.01mm-0.4mm
Tail frame taper:	MT2
Maximum stroke of tool rest plate:	2.16"(55mm)
Maximum stroke of middle plate:	2.95"(75mm)
Maximum stroke of bottom plate:	26.77"(680mm)
Maximum stroke of tailstock sleeve:	2.36"(60mm)

Figure 3.1: Detailed product parameters for the RC-210E lathe.

Table 3.1: Banfluxion RC-210E Technical Specifications

Parameter	Value
Model	RC-210E
Voltage	AC110V 50/60Hz (Brushless Motor)
Power	1100W (1.5HP)
Length of Center	31.50" (800mm)
Swing Over Bed	8.27" (210mm)
Rotary Diameter of Tool Rest	5.51" (140mm)
Spindle Bore	1.50" (38mm)
Diameter of Chuck	4.92" (125mm)
Width of Lathe Bed	3.94" (100mm)

Parameter	Value
Thread Standard	Metric/Imperial/Customized
Turning Delay Start Time	1s-30s
Number of Spindle Speeds	Infinitely variable speeds
Range of Inch Threads	10-44 T.P.I
Range of Metric Threads	0.5mm-3mm
Spindle Taper	MT5
Knife Rest Labour	Horizontal four-station
Spindle Rotation Speed	50-2500rpm
Precision of the Spindle	0.01mm
Automatic Feed Range	0.01mm-0.4mm
Tail Frame Taper	MT2
Maximum Stroke of Tool Rest Plate	2.16" (55mm)
Maximum Stroke of Middle Plate	2.95" (75mm)
Maximum Stroke of Bottom Plate	26.77" (680mm)
Maximum Stroke of Tailstock Sleeve	2.36" (60mm)
Product Dimensions	46.1 x 13 x 14.2 inches (117 x 33 x 36 cm)
Item Weight	187.4 pounds

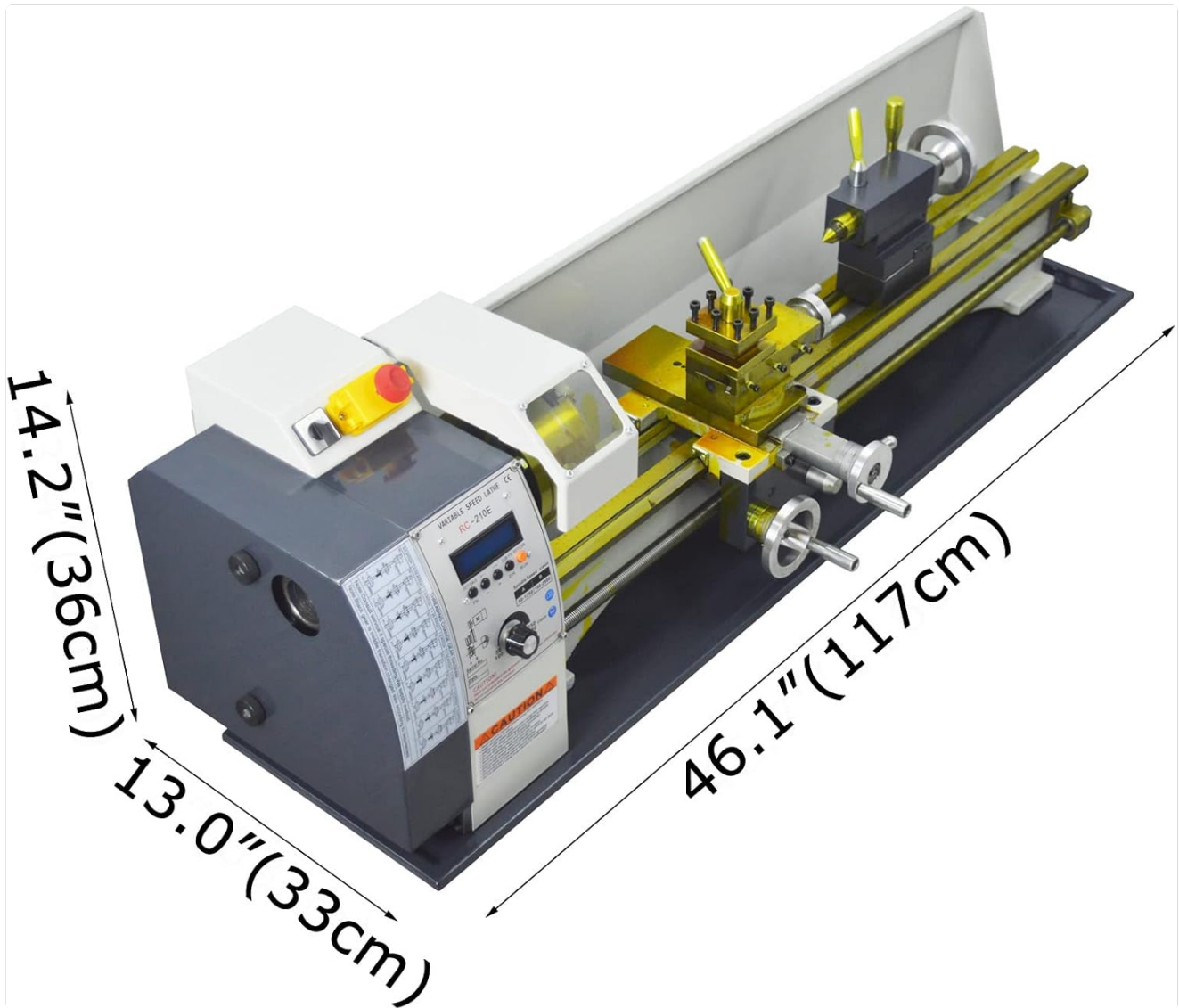

Figure 3.2: Physical dimensions of the RC-210E lathe.

4. UNPACKING AND INITIAL SETUP

4.1 Included Items

Verify that all the following items are present in the packaging:

- RC-210E Lathe (1 unit)
- Base Oil Pan (1 unit)
- English Manual (1 unit)
- Oil Can (1 unit)
- Hexagon Wrench (5 units)
- Open Spanner (2 units)
- Screwdriver (2 units)
- Chuck Jaw (3 units)
- Chuck Spanner (1 unit)

4.2 Placement and Installation

1. Choose a stable, level workbench capable of supporting the lathe's weight (approximately 187.4 lbs).
2. Ensure adequate clearance around the machine for safe operation and maintenance.

3. Mount the lathe securely to the workbench using appropriate fasteners (not included).
4. Install the base oil pan beneath the lathe to collect chips and coolant.
5. Connect the lathe to a grounded 110V AC power outlet.

5. OPERATION

5.1 Control Panel Overview

The control panel provides access to all operational settings, including speed adjustment, thread selection, and start/stop functions. Familiarize yourself with each button and display before operation.

5.2 Spindle Speed Adjustment

The RC-210E features infinitely variable spindle speeds from 50-2500rpm. Use the speed control knob on the panel to adjust the rotation speed according to the material and cutting tool requirements.

5.3 Threading Operations

To perform threading, select the desired thread standard (metric or imperial) directly from the control panel. The machine automatically adjusts for the selected thread pitch (Metric: 0.5mm-3mm; Inch: 10-44 T.P.I) without requiring manual gear changes.

5.4 Automatic Feed

Engage the automatic feed function for consistent material removal along the X-axis. The automatic feed range is adjustable from 0.01mm to 0.4mm. Refer to the control panel for specific settings.

5.5 Starting and Stopping the Lathe

- **Manual Start:** Press the green 'Start' button on the control panel.
- **Automatic Start:** Set parameters on the control panel and save to initiate reciprocating turning or thread turning.
- **Delay Automatic Start:** Utilize the delay function (1s-30s) for timed starts.
- **Emergency Stop:** In case of an emergency, press the red emergency stop button immediately to cut off power.

6. MAINTENANCE

Regular maintenance is crucial for the longevity and optimal performance of your lathe.

- **Cleaning:** After each use, clean the lathe bed, chuck, and tool post to remove chips and debris. Use a brush or air gun, ensuring power is disconnected.
- **Lubrication:** Regularly lubricate all moving parts, including lead screws, gears, and slides, with appropriate machine oil. Refer to the lubrication points indicated in the machine diagram (if available).
- **Inspection:** Periodically inspect belts, electrical connections, and fasteners for wear or looseness. Tighten or replace as necessary.
- **Chuck Maintenance:** Keep chuck jaws clean and lubricated. Ensure they operate smoothly.

7. TROUBLESHOOTING

This section provides general guidance for common issues. For complex problems, contact customer support.

- **Machine Does Not Start:** Check power connection, ensure emergency stop button is disengaged, and verify all safety interlocks are correctly positioned.
- **Abnormal Noise/Vibration:** Inspect for loose components, worn bearings, or improper lubrication. Adjust or replace as needed.
- **Inaccurate Cuts:** Verify tool sharpness, proper workholding, and correct machine settings. Check for play in slides or lead screws.
- **Automatic Feed Not Working:** Ensure the automatic feed mechanism is engaged and the settings on the control panel are correctly configured.

8. WARRANTY AND SUPPORT

For warranty information, technical support, or spare parts, please refer to the contact details provided with your purchase documentation or visit the official Banfluxion website. Keep your purchase receipt as proof of purchase for warranty claims.
