



Manuals.plus /

› Flylin /

› Flylin 5 PSI Pressure Transducer Sensor Instruction Manual

## Flylin 5549e4de-1daa-4c43-bd34-d76051439da1

# Flylin 5 PSI Pressure Transducer Sensor Instruction Manual

Model: 5549e4de-1daa-4c43-bd34-d76051439da1

## 1. INTRODUCTION

---

This manual provides detailed instructions for the installation, operation, and maintenance of the Flylin 5 PSI Pressure Transducer Sensor. This high-precision sensor is designed for reliable pressure measurement in various applications, including oil, fuel, air, and water systems. Please read this manual thoroughly before installation and use to ensure proper function and safety.

## 2. PRODUCT FEATURES

---

- **High Precision:** Features a small output error of  $\pm 1.0\%$ FS across the full temperature range, ensuring high sensitivity and accuracy.
- **Wide Application:** Suitable for detecting pressure in oil tanks, gas tanks, diesel tanks, and systems involving oil, fuel, diesel, gas, water, or air.
- **Voltage Protection:** Equipped with complete surge voltage protection for safe operation.
- **Durable Materials:** Constructed from high-grade 316 stainless steel and a high-quality ceramic pressure chip, designed for performance in diverse environments.
- **Voltage Signal Output:** Provides a 0.5V – 4.5V linear voltage output. Specifically, 0 psi outputs 0.5V, 2.5 psi outputs 2.5V, and 5 psi outputs 4.5V.



Figure 2.1: Key Features of the Pressure Transducer.

### 3. TECHNICAL SPECIFICATIONS

Parameter	Value	Parameter	Value
Measuring Range	5 PSI	Burst Pressure	300%FS
Accuracy	±1.0%FS	Cycle Life	500,000 times
Output Signal	0.5-4.5V	Sensor Core	AL2O3-96% ceramic sensor
Supply Voltage	5-16VDC	Pressure Medium	Non-corrosive liquid or gas
Operating Temperature	-40 ~ 105°C	Pressure Connection	1/8" NPT
Compensation Temperature	-20 ~ 80°C	Electrical Connection	Packard connection
Operating Current	≤3mA	Housing Material	316 Stainless Steel
Temperature Drift (zero & sensitivity)	≤±0.03%FS/°C	Protection Class	IP65
Long-term Stability	≤±0.2%FS/year	Explosion-proof Class	Exia II CT6
Response Time	≤3ms	Weight	≈0.080kg
Overload Pressure	150%FS	Electromagnetism Compatibility	EN50081-1; EN50082-2; IEC61000-4-3

# MATERIAL TYPE

## A VARIETY OF MODELS TO CHOOSE FROM



Figure 3.1: Product Dimensions.

## 4. SETUP AND INSTALLATION

---

Proper installation is crucial for the accurate and safe operation of the pressure transducer. Follow these steps carefully:

### 1. Physical Installation:

- Ensure the system where the sensor will be installed is depressurized and drained.
- Thread the sensor into the 1/8" NPT port. Use appropriate thread sealant (e.g., PTFE tape) to ensure a leak-free connection. Do not overtighten.
- Position the sensor to avoid direct exposure to extreme temperatures or physical damage.

### 2. Electrical Connection:

- Connect the provided harness to the sensor's Packard connector. Ensure a secure fit.
- Refer to the wiring diagram below for correct pin assignments. The sensor typically uses a three-wire connection:
  - Pin 1 (Red wire): Supply+ (5-16VDC)
  - Pin 2 (Black wire): GND (Ground)
  - Pin 3 (Yellow wire): Output (0.5-4.5V)
- Ensure all electrical connections are secure and insulated to prevent short circuits or signal interference.

Connection	Pin	Function	Color
	1	Supply+	Red
	2	GND	Black
	3	Output	Yellow

Figure 4.1: Electrical Wiring Diagram.

Figure 4.2: Example of Sensor Installation.

Your browser does not support the video tag.

Video 4.1: Overview of Fuel Oil Pressure Sensor Transducer and Harness Kit. This video demonstrates the components and basic connection of a similar pressure sensor and its harness.

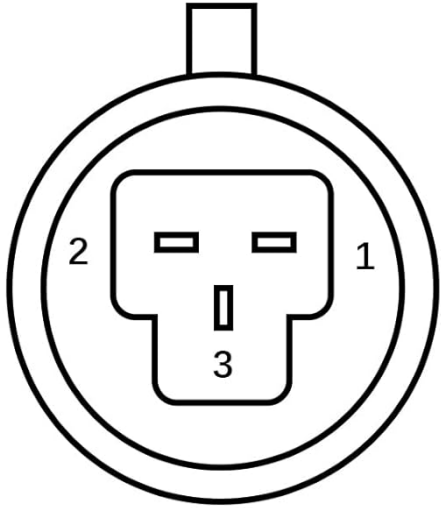
## 5. OPERATING PRINCIPLES

The Flylin 5 PSI Pressure Transducer converts applied pressure into a linear voltage output. As pressure increases, the output voltage increases proportionally within the specified range of 0.5V to 4.5V for 0 to 5 PSI.

- At 0 PSI, the sensor outputs 0.5V.
- At 2.5 PSI, the sensor outputs 2.5V.
- At 5 PSI, the sensor outputs 4.5V.

This linear relationship allows for easy integration with microcontrollers, data acquisition systems, or analog gauges that can

interpret a 0.5-4.5V signal. Ensure your receiving device is calibrated to match this output range for accurate readings.

## 6. MAINTENANCE

The Flylin pressure transducer is designed for long-term reliability with minimal maintenance. However, periodic checks can help ensure optimal performance:

- **Visual Inspection:** Regularly inspect the sensor and its connections for any signs of physical damage, corrosion, or leaks.
- **Connection Integrity:** Verify that the electrical connector remains securely attached and that wiring is intact.
- **Cleaning:** If operating in a dusty or dirty environment, gently clean the exterior of the sensor with a soft, damp cloth. Avoid using harsh chemicals or abrasive materials.
- **Environmental Protection:** While the sensor is IP65 rated for water and dust resistance, prolonged exposure to extreme conditions beyond its specified operating range should be avoided.

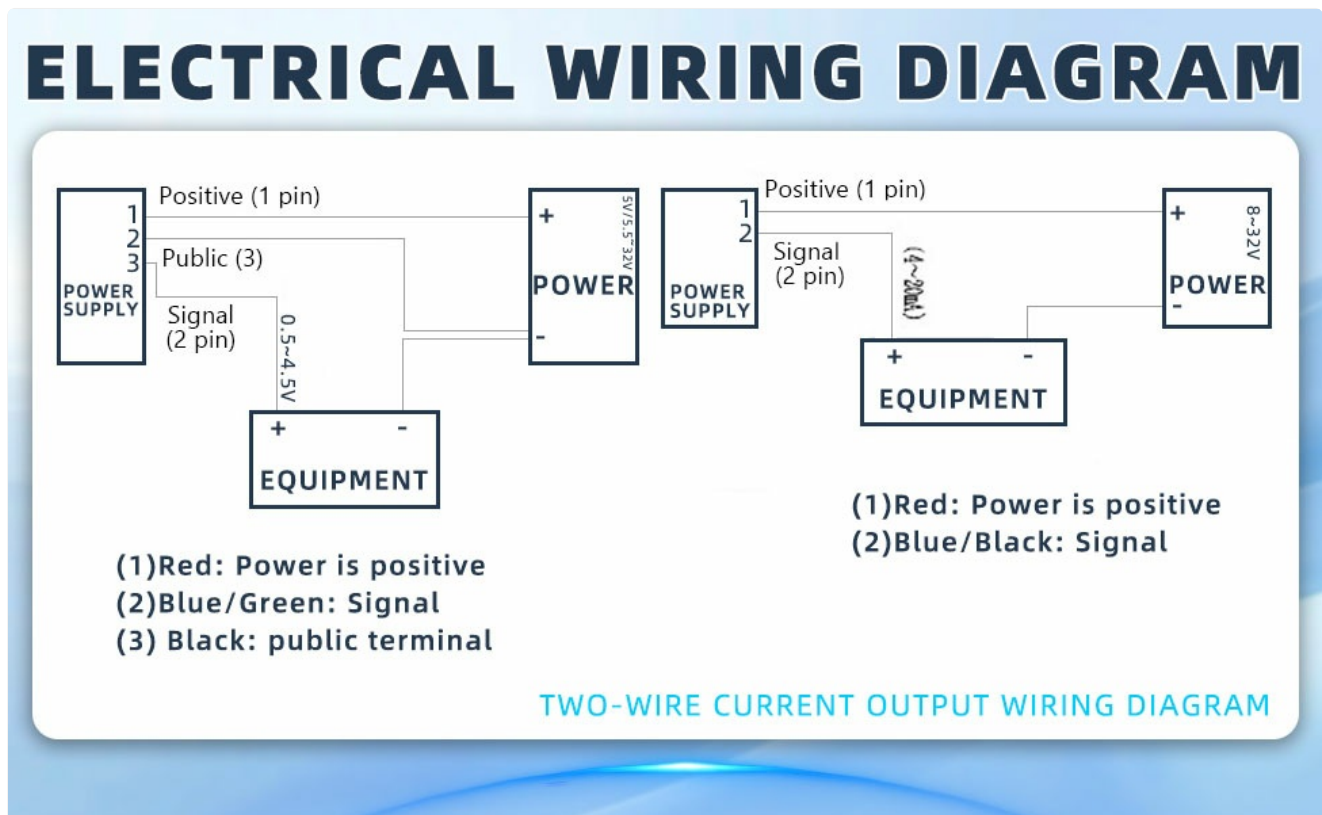

Figure 6.1: Pressure Transducer and Connector.

## 7. TROUBLESHOOTING

If you encounter issues with your pressure transducer, consider the following troubleshooting steps:

- **No Output or Incorrect Reading:**
  - Verify the power supply voltage is within the 5-16VDC range and correctly connected (Red to Supply+, Black to GND).
  - Check all wiring connections for looseness, corrosion, or damage. Refer to the wiring diagram (Figure 4.1).
  - Ensure the sensor is properly threaded and sealed, with no leaks affecting pressure measurement.
  - Confirm that the receiving device (e.g., multimeter, microcontroller) is correctly configured to read a 0.5-4.5V analog signal.
  - Inspect the sensor's orifice for any obstructions or foreign material.

- **Inconsistent Readings:**

- Check for electrical noise in the power supply or signal line. Consider adding noise filters if necessary.
- Ensure the sensor is not subjected to excessive vibration or rapid temperature fluctuations outside its operating range.
- Verify the integrity of the pressure source; fluctuating pressure can lead to inconsistent readings.

- **Sensor Not Fitting:**

- Confirm the thread type and size (1/8" NPT) matches your application.

If issues persist after performing these checks, contact customer support for further assistance.

## 8. APPLICATIONS

---

The Flylin 5 PSI Pressure Transducer is versatile and can be utilized in a wide range of industrial and automotive applications where accurate pressure monitoring of non-corrosive liquids or gases is required. Common applications include:

- Automotive systems (fuel pressure, oil pressure)
- Industrial automation and process control
- Fluid control systems
- Water treatment facilities
- Machinery manufacturing
- Petrochemical industry
- Food and pharmaceutical industry (for non-corrosive media)



Figure 8.1: Diverse Applications of the Pressure Transducer.

## 9. WARRANTY AND SUPPORT

---

For warranty information and customer support, please refer to the product packaging or contact your retailer. Ensure you have your product model number and purchase details available when seeking support.