

manuals.plus /

- › [VEVOR](#) /
- › [VEVOR 2-Speed 56-Frame 4HP Hot Tub Spa Pump Instruction Manual](#)

VEVOR HDP2200II

VEVOR 2-Speed 56-Frame 4HP Hot Tub Spa Pump Instruction Manual

MODEL: HDP2200II

1. INTRODUCTION

This manual provides essential information for the safe and efficient installation, operation, and maintenance of your VEVOR 2-Speed 56-Frame 4HP Hot Tub Spa Pump. Please read this manual thoroughly before use and retain it for future reference.



Image 1: VEVOR 2-Speed 56-Frame 4HP Hot Tub Spa Pump.

2. SAFETY INFORMATION

Always observe basic safety precautions to reduce the risk of fire, electric shock, or injury to persons.

- **Electrical Safety:** Ensure the power supply matches the pump's voltage (AC 220-240V 60Hz). All wiring must be performed by a qualified electrician and comply with local and national electrical codes. Always disconnect power before servicing.
- **Grounding:** The pump must be properly grounded to prevent electric shock.
- **Thermal Protection:** The pump is equipped with Texas Instruments Thermal Protection, which automatically shuts off the motor if it overheats. Do not bypass this safety feature.
- **Water Temperature:** Do not exceed a maximum water temperature of 50°C (122°F).
- **Installation:** Install the pump in a well-ventilated area, protected from direct sunlight and extreme weather conditions.



OVERHEAT AUTO SHUTDOWN

Ensure peace of mind during your spa moments



Home Spas Underground Spas Outdoor Spas



Texas Instruments Thermal Protection
High Sensitivity, Rapid Response

Image 2: The pump features Texas Instruments Thermal Protection for automatic shutdown upon overheating.

3. PRODUCT OVERVIEW

The VEVOR 2-Speed 56-Frame 4HP Hot Tub Spa Pump is designed for efficient water circulation and powerful jet action in hot tubs and spas. It features a robust pure copper wire motor and advanced sealing technology.

Key Features:

- **Two-Speed Design:** Offers both high-speed (4 HP / 210 GPM) for powerful massage and low-speed (0.7 HP / 103 GPM) for quiet circulation and energy efficiency.
- **56-Frame Motor:** A mainstream pump model compatible with many OEM setups.
- **Pure Copper Wire Motor:** Ensures durability and stable long-term operation, tested through 80,000 electric cycles.
- **Fluororubber Shaft Seals:** Provides superior sealing against leakage, resisting high temperatures, corrosion, oil, and aging.
- **90° Rotational Interface:** Allows for flexible installation in various spaces by adjusting the pump head and interface angle.
- **Thermal Protection:** Integrated Texas Instruments Thermal Protection monitors motor temperature and automatically disconnects power to prevent damage.

TWO-SPEED FLOW CONTROL

Unleash robust power for enduring performance



Durable Pure
Copper Motor
Tested through
80,000 power cycles



Anti-Creep
Bearings
Fearless of high
temperature and
pressure

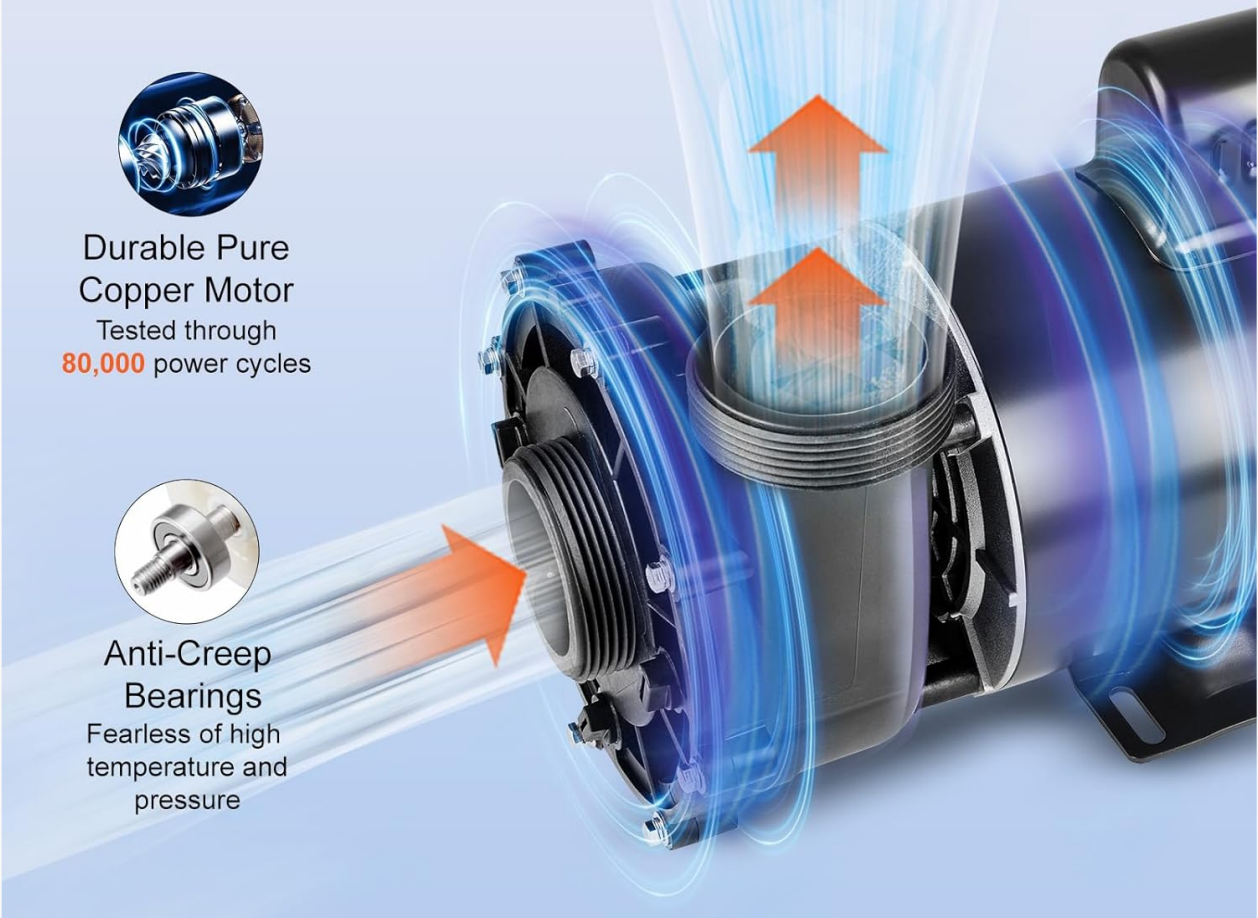

High Speed: **4.0 HP / 210 GPM / 65.61 ft (20 m)**

Low Speed: **0.7 HP / 103 GPM / 16.07 ft (4.9 m)**

Image 3: Illustration of the two-speed flow control, showing high and low speed specifications.



FLUORORUBBER SHAFT SEALS

Fearless against water impurities, Defying impact and wear



Superior
Sealing



Impurity
Isolation



High Temperature
Resistance



Stable
Operation

Image 4: Fluororubber shaft seals provide superior sealing and resistance to various elements.

4. SPECIFICATIONS

Attribute	Value
Brand	VEVOR
Model Number	HDP2200II
Style	56-Frame 4HP
Power Source	AC
Voltage	220-240 Volts (AC)
High Speed Horsepower	4.0 HP
High Speed Flow Rate	210 Gallons Per Minute (GPM)
High Speed Lifting Height	65.61 Feet (20 m)
Low Speed Horsepower	0.7 HP
Low Speed Flow Rate	103 Gallons Per Minute (GPM)
Low Speed Lifting Height	16.07 Feet (4.9 m)
Port Size	2 inches
Product Dimensions	15.96"L x 4.88"W x 8.89"H
Item Weight	37.7 Pounds
Material	Polyvinyl Chloride

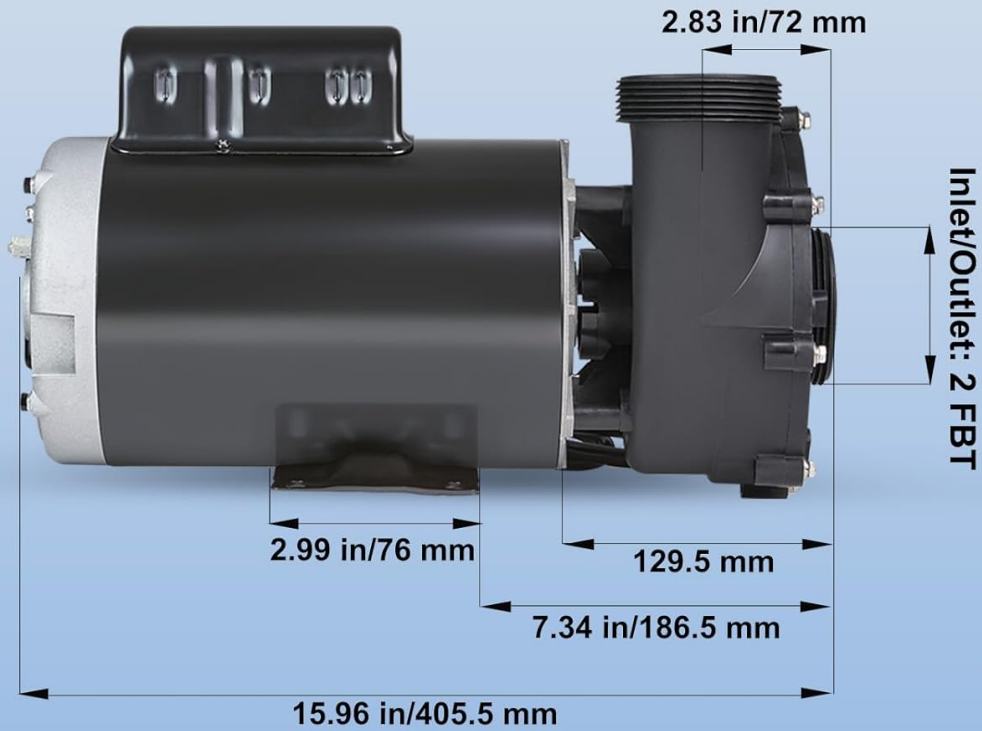

Item Model Number

56HT400-II

Interface Rotation Angle

90

Speed Type

Two Speed

High Speed Horsepower / Flow / Head Lift

4.0 HP / 210 GPM / 65.61 ft (20 m)

Low Speed Horsepower / Flow / Head Lift

0.7 HP / 103 GPM / 16.07 ft (4.9 m)

Image 5: Detailed dimensions of the VEVOR 2-Speed Spa Pump.

5. SETUP AND INSTALLATION

Proper installation is crucial for the pump's performance and longevity. Follow these steps carefully.

5.1. Pre-Installation Checks

- Ensure the installation location is horizontal, stable, and provides adequate ventilation.
- Verify that the power supply voltage and frequency match the pump's requirements (AC 220-240V, 60Hz).
- Confirm that the plumbing connections are 2 inches in diameter. Two 2-inch connectors are included for convenience.

5.2. Adjusting Discharge Location

The pump head and interface can be rotated to adjust the discharge direction, simplifying pipe connections in tight spaces.

1. Loosen the indicated 4 screws on the pump's rear cover and remove them.
2. Carefully rotate the pump head to the desired discharge location (e.g., 3 o'clock, 9 o'clock, or 12 o'clock).
3. Reinsert and tighten the 4 screws to secure the pump head in the new position.

90-DEGREE ROTATIONAL INTERFACE

Ideal for installing pipes in different directions



Image 6: The 90-degree rotational interface allows for flexible adjustment of the pump's discharge direction.

Your browser does not support the video tag.

Video 1: This video demonstrates the wiring operation for LINGXIAO 56WUA series pumps, which is applicable to the VEVOR 2-Speed Spa Pump.

Your browser does not support the video tag.

Video 2: This video illustrates the wiring operation for LINGXIAO 48WUA series SPA pumps, providing guidance for both single and two-speed setups.

Your browser does not support the video tag.

Video 3: This video demonstrates the cable operation for a LINGXIAO circulation pump, offering insights into proper wiring.

5.3. Electrical Wiring (230V/60Hz Default)

Turn off the power first. Ensure the corresponding voltage of the circuit (230V/60Hz). Refer to the wiring diagram on the pump's label for specific connections. Generally:

- **Red wire (High speed):** Connect to terminal 'H'.
- **White wire (Neutral wire):** Connect to terminal 'C'.
- **Black wire (Low speed):** Connect to terminal 'L'.
- **Green wire (Ground wire):** Connect to terminal 'Ground'.

After connecting the power supply, perform testing and inspection to confirm that all components work correctly.



Image 7: Close-up of the pump's label showing the wiring diagram for high and low speed connections.

6. OPERATING INSTRUCTIONS

Your VEVOR spa pump offers two operating speeds to suit your needs:

- **High Speed (4 HP / 210 GPM):** Provides maximum water flow for powerful jet action and deep massage. Use this setting when you desire strong hydrotherapy.
- **Low Speed (0.7 HP / 103 GPM):** Offers reduced water flow for quiet, continuous circulation and energy-efficient operation. Ideal for maintaining water quality and temperature when not actively using the jets.

Switching between speeds is typically controlled by your hot tub's control panel. Refer to your hot tub's user manual for specific instructions on how to select pump speeds.

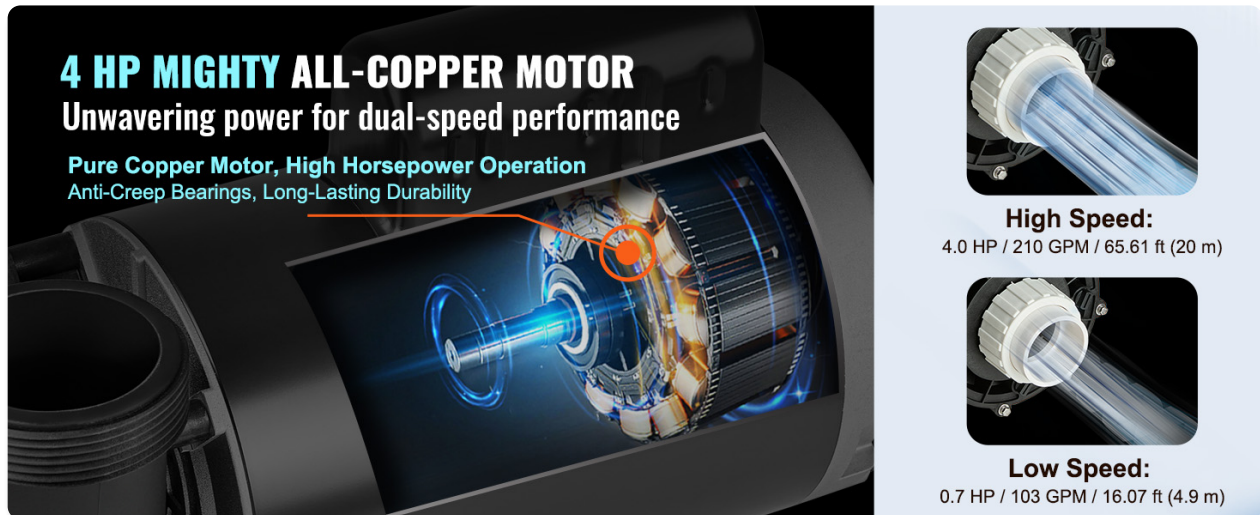

Image 8: The pure copper motor provides unwavering power for both high and low speed operations.

7. MAINTENANCE

Regular maintenance ensures optimal performance and extends the lifespan of your spa pump.

- **Inspect for Leaks:** Periodically check all plumbing connections and seals for any signs of leakage. Address any leaks promptly.
- **Clean Pump Housing:** Keep the exterior of the pump clean and free from debris to ensure proper ventilation and prevent overheating.
- **Winterization:** If you live in an area with freezing temperatures, follow proper hot tub winterization procedures, which typically include draining the pump to prevent freeze damage.
- **Professional Service:** For any complex issues or internal repairs, consult a qualified spa technician.

8. TROUBLESHOOTING

If you encounter issues with your pump, refer to the following common troubleshooting tips. Always disconnect power before attempting any inspection or repair.

- **Pump Not Starting:** Check power supply, circuit breaker, and wiring connections. Ensure the thermal protection has not tripped due to overheating.

- **Low Water Flow:** Inspect for clogged filters, obstructions in the plumbing, or air in the pump. Ensure the water level in the hot tub is adequate.
- **Unusual Noise:** Check for debris in the impeller, loose mounting bolts, or air in the system.
- **Leaking:** Inspect all unions, seals, and gaskets. Tighten connections or replace worn components as necessary.

If the problem persists after attempting these steps, contact customer support or a qualified technician.

9. WARRANTY AND SUPPORT

For warranty information and customer support, please refer to the documentation included with your purchase or visit the official VEVOR website. VEVOR offers various protection plans for extended coverage.

Available Protection Plans:

- 3-Year Protection Plan
- 4-Year Protection Plan
- Complete Protect (monthly subscription covering eligible past and future purchases)

For additional assistance, you may visit the [VEVOR Store on Amazon](#).