



[Manuals.plus](#) /

› [FLEXISPOT](#) /

› FLEXISPOT E6 MAX Standing Desk Instruction Manual

FLEXISPOT E6 MAX

FLEXISPOT E6 MAX Standing Desk Instruction Manual

Model: E6 MAX | Brand: FLEXISPOT

INTRODUCTION

This manual provides detailed instructions for the assembly, operation, and maintenance of your FLEXISPOT E6 MAX Bamboo 72x30 Inch Dual Motor 3-Stage Heavy Duty Standing Desk. Please read this manual thoroughly before use to ensure proper function and safety.



The FLEXISPOT E6 MAX standing desk, featuring a bamboo top and black frame, is designed for a modern home office environment.

SAFETY INFORMATION

WARNING:

- This desk is height-adjustable. Always use the controls with caution to prevent injury.
- Do not exceed the maximum weight limit of 330 pounds.
- Ensure the desk is properly assembled and anchored to the floor to prevent tipping.
- Keep children and pets away from the desk during height adjustments.

PACKAGE CONTENTS

Verify that all components are present before beginning assembly. The package includes the desk frame, bamboo desktop, and the following accessories:

- Set of Wheels (4 units)

- Cable Manager
- Velcro Straps
- All necessary assembly tools

COMPLIMENTARY ACCESSORIES

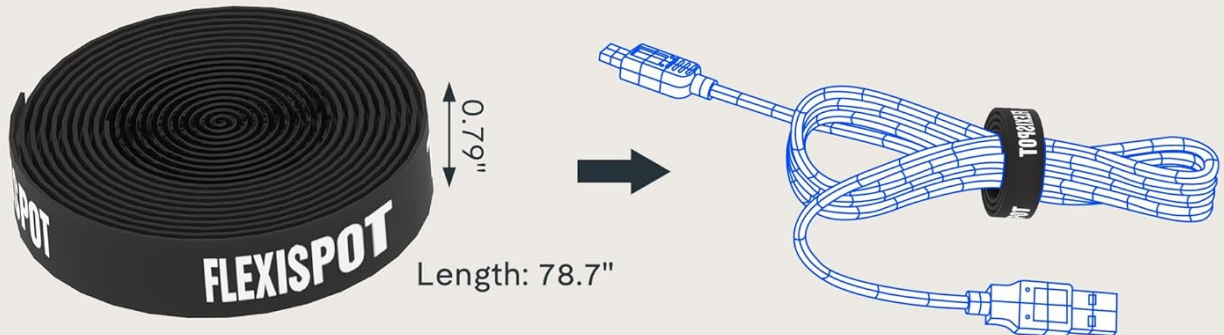

Velcro Straps



Set of Wheels

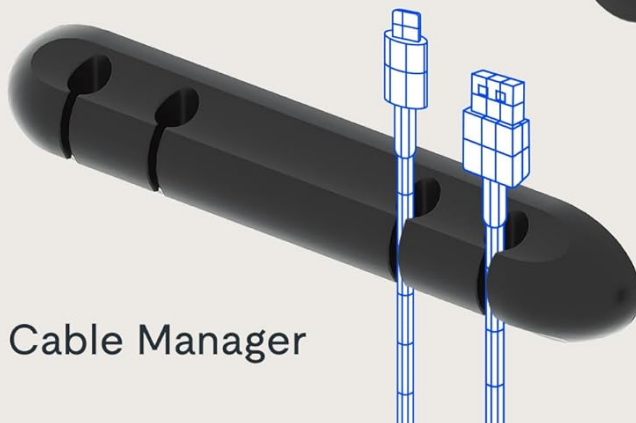

Cable Manager

Complimentary accessories included with the FLEXISPOT E6 MAX desk, such as wheels, a cable manager, and velcro straps.

ASSEMBLY INSTRUCTIONS

Assembly instructions are included with the product. All necessary tools for assembly are provided. Please follow the step-by-step guide provided in the separate assembly manual for detailed instructions. Ensure all screws are tightened securely before use.

This video demonstrates the assembly process for a FlexiSpot desk, providing visual guidance for installation.

SETUP AND OPERATION

Height Adjustment

The FLEXISPOT E6 MAX features a dual-motor, three-stage leg design, allowing for continuous height adjustment

from 24.4 inches to 50 inches. This broad range accommodates various user heights, from children to extra-tall adults.

THREE-STAGE LEG

Continuous Height Adjustment
from 24.4"-50"

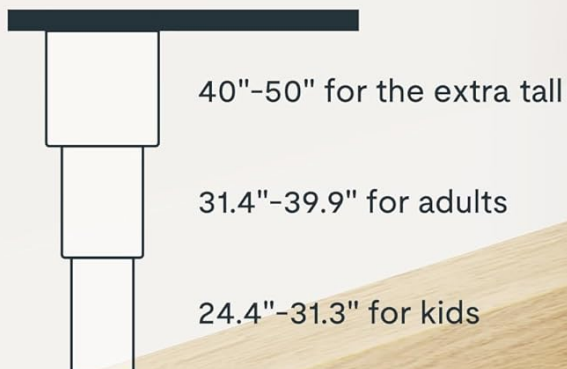

Detail of the three-stage leg, showing continuous height adjustment from 24.4 inches to 50 inches.

Control Panel and Memory Presets

The intuitive digital control panel includes up/down buttons and four height memory settings. You can preset your preferred sitting and standing heights for quick and efficient adjustments.



Up/Down

4 Height Memory Settings

PROGRAMMABLE CONTROL PANEL

The programmable control panel features blue backlighting, up/down controls, and four memory buttons for personalized height settings.

Anti-Collision Feature

The desk includes a built-in anti-collision system to prevent accidents. This feature automatically stops and reverses the desk's movement if it encounters an obstruction during height adjustment, protecting users, children, and pets.

ANTI-COLLISION FEATURE

Includes a built-in system to prevent accidents, protecting children and pets during height adjustments.



The anti-collision feature ensures safety by stopping desk movement upon detecting an obstruction.

Stability and Quiet Operation

The desk's strong steel structure and dual motors ensure smooth and steady movement, even at its highest level, with minimal wobble. The quiet dual motors operate at less than 50dB, allowing for adjustments without disturbing your surroundings.

POWERFUL DUAL MOTOR

Whisper-quiet, Smoother and More Stable.

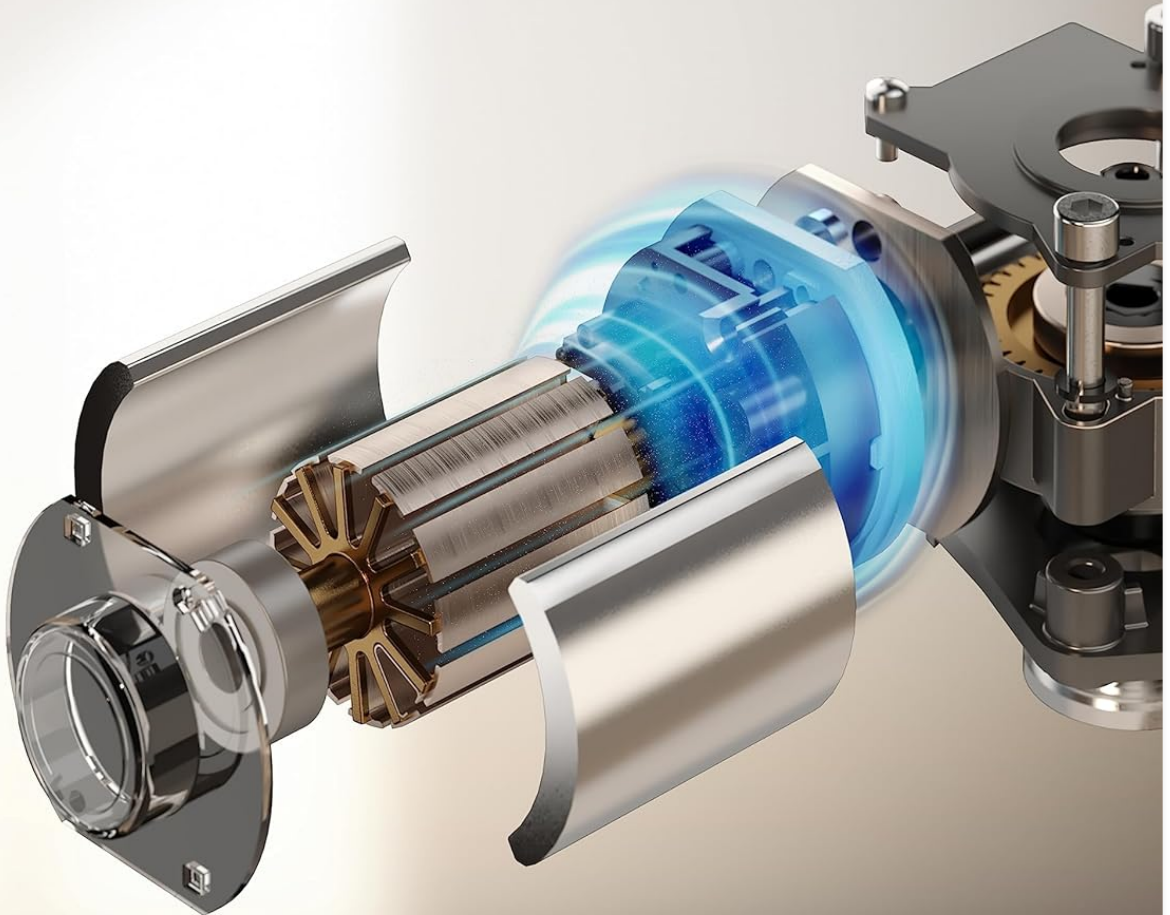

Internal view of the powerful dual motor, highlighting its quiet and stable operation.

This video provides an overview of the E6 MAX product features, including its stable and quiet operation.

MAINTENANCE

To maintain your FLEXISPOT E6 MAX desk, regularly wipe the bamboo desktop with a soft, damp cloth. Avoid harsh chemicals that may damage the finish. Periodically check all screws and connections to ensure they remain tight. Keep the motor and electrical components free from dust and moisture.

TROUBLESHOOTING

If you encounter any issues with your desk, please refer to the following common troubleshooting tips:

- **Desk not moving:** Check all power connections. Ensure the power cable is securely plugged into both the desk and the wall outlet.
- **Uneven movement:** Ensure the desk is on a level surface. Check for any obstructions under the desk or in the leg mechanisms.
- **Error codes:** Consult the separate assembly manual for specific error code interpretations and solutions.

If problems persist, please contact FLEXISPOT customer support.

SPECIFICATIONS

Feature	Detail
Brand	FLEXISPOT
Model Name	FLEXISPOT E6 MAX
Desktop Material	Bamboo
Frame Material	Metal
Color (Current Variant)	Black Frame + Curved Bamboo Top
Size (Current Variant)	72"x30" Bamboo One-Piece
Product Dimensions (D x W x H)	47.5"D x 29.5"W x 23.6"H
Height Adjustment Range	24.4" - 50"
Lifting Mechanism	Electric/Dual Motor
Maximum Weight Capacity	330 Pounds
Noise Level	Under 50dB
Control Panel	Programmable with 4 Memory Settings
Special Features	Anti-collision system, Cable Management, Wheels
Assembly Required	Yes (Tools Included)

DIMENSIONS

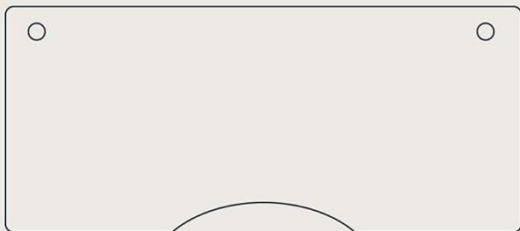

Desktop

72"-30" diameter

Can hold three 27 inch computers.

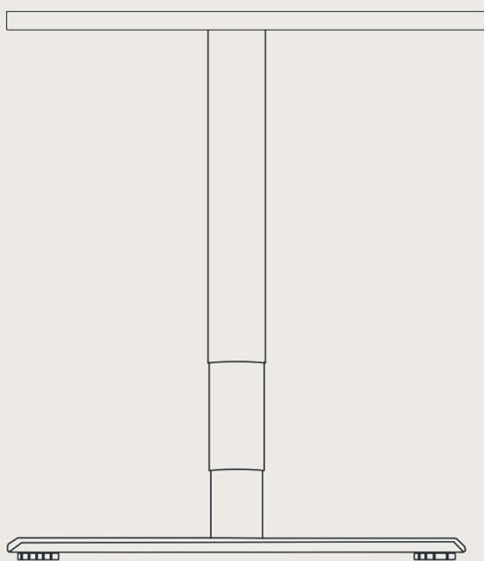

Desk Frame

TALL

40"-48.8" for the extra

MEDIUM

31.4"-39.9" for adults

SHORT

23.6"-31.1" for kids

Detailed dimensions of the FLEXISPOT E6 MAX desk, showing desktop size and adjustable frame heights.

WARRANTY AND SUPPORT

Your FLEXISPOT E6 MAX desk comes with a comprehensive warranty:

- **10-Year Coverage:** Desk frame and motor.
- **2-Year Protection:** Control panel and electronics.

For any assistance, warranty claims, or further inquiries, please contact FLEXISPOT customer support directly. Refer to your purchase documentation for specific contact details.

This video highlights the key features and benefits of the FLEXISPOT E6 series, including its quality and design.