



[Manuals.plus](#) /

› [Mount Plus](#) /

› Mount Plus MED02 Medical Wall Mount Workstation User Manual

Mount Plus MED02

Mount Plus MED02 Medical Wall Mount Workstation User Manual

PRODUCT OVERVIEW

The Mount Plus MED02 Medical Wall Mount Workstation is designed to provide an ergonomic and space-saving solution for healthcare environments. This workstation integrates a monitor arm, a folding keyboard tray, and a large sliding mouse pad, along with a convenient scanner holder. It supports monitors ranging from 17 to 35 inches, offering flexibility and efficiency for medical professionals.



Image: The Mount Plus MED02 workstation mounted on a wall in a hospital room, providing a compact and accessible computer setup next to a patient bed.

Key features include a large integrated sliding mouse pad for ample movement, a foldable keyboard tray for adjustable height and comfortable typing, and a gas spring monitor arm that allows for easy height adjustment, rotation, tilt, and swivel. Constructed from medical-grade materials, the workstation is designed for hygiene and durability, resisting stains and scratches. Convenient scanner access is provided on both sides to enhance serviceability and efficiency.

SETUP AND INSTALLATION

Proper installation is crucial for the stability and functionality of your Mount Plus MED02 workstation. Ensure the mounting surface is structurally sound and capable of supporting the weight of the workstation and your equipment. It is recommended to consult a professional for installation if you are unsure about wall integrity.

Mounting the Unit

1. **Select Location:** Choose a suitable wall location, ensuring adequate space for full range of motion and access.
2. **Mark Drilling Points:** Use the provided mounting template (if included) or measure carefully to mark the

drilling points for the wall plate.

3. **Drill Holes:** Drill pilot holes according to the marked points and insert appropriate wall anchors for your wall type (e.g., concrete, wood stud).
4. **Attach Wall Plate:** Securely fasten the wall plate to the wall using the provided screws.
5. **Assemble Arm:** Attach the monitor arm assembly to the wall plate following the detailed instructions in the included hardware manual.
6. **Attach Monitor:** Secure your VESA-compatible monitor (17-35 inches) to the monitor head using the appropriate screws.
7. **Cable Management:** Route all cables through the integrated cable management channels to maintain a clean and organized workspace.

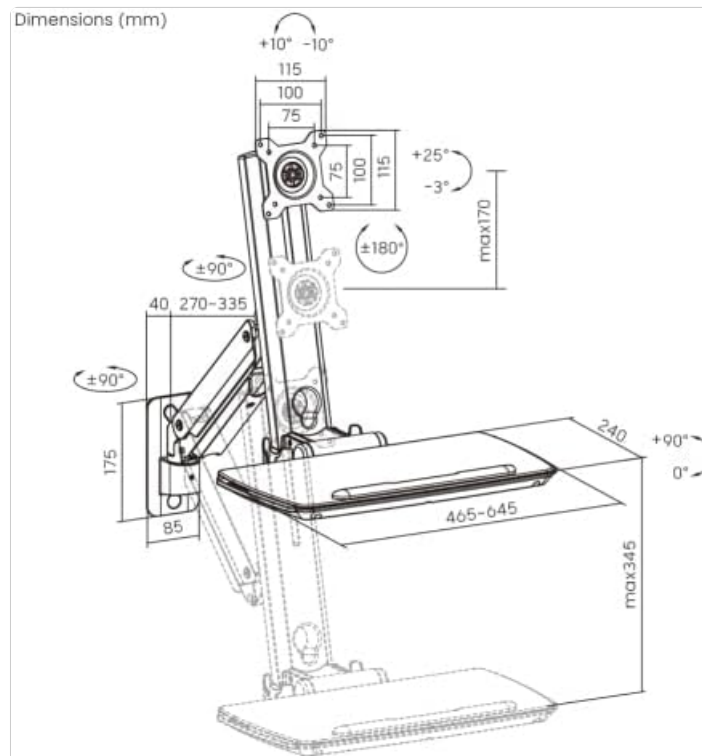

Image: A technical diagram illustrating the dimensions and adjustable ranges of the Mount Plus MED02 workstation, including monitor height, tilt, swivel, and keyboard tray extension.

OPERATING INSTRUCTIONS

The Mount Plus MED02 workstation offers various adjustments to optimize your working posture and screen visibility.

Monitor Adjustments

- **Height Adjustment:** Use the easy-to-adjust knob located on the monitor arm to raise or lower the screen to your desired ergonomic height. The gas spring mechanism assists in smooth vertical movement.
- **Tilt and Swivel:** The monitor can be tilted +25° to -3° and swiveled +/-90° to reduce glare and achieve optimal viewing angles.
- **Rotation:** Rotate the monitor 360° for portrait or landscape orientation as needed.



Image: The workstation shown fully extended, demonstrating the monitor, keyboard tray, and mouse pad in an active use configuration.

Keyboard Tray and Mouse Pad

- **Folding Tray:** The keyboard tray can be folded up against the wall when not in use, saving valuable space. Simply lift the tray until it locks into its vertical position.
- **Sliding Mouse Pad:** Extend the integrated sliding mouse pad from either side of the keyboard tray to create additional workspace for your mouse.

Scanner Holder

The workstation includes a scanner holder that provides convenient access from both the left and right sides, improving workflow efficiency.

Video: An official product video demonstrating the various adjustable features of the Mount Plus Medical Monitor Wall Mount, including monitor height, tilt, swivel, and the functionality of the keyboard tray and scanner holder.

MAINTENANCE

To ensure the longevity and hygienic condition of your Mount Plus MED02 workstation, follow these maintenance guidelines:

- **Cleaning:** Regularly wipe down all surfaces with a mild, non-abrasive cleaner suitable for medical-grade materials. Avoid harsh chemicals that may damage the finish.
- **Inspection:** Periodically check all screws and connections to ensure they are tight and secure. Loose components can affect stability and safety.
- **Moving Parts:** The gas spring mechanism is designed for smooth operation. Avoid applying excessive force when adjusting the monitor height. If adjustments become stiff, consult the troubleshooting section or contact support.

TROUBLESHOOTING

If you encounter any issues with your workstation, refer to the following common troubleshooting steps:

- **Workstation feels unstable:** Ensure all mounting screws are securely tightened to the wall and the arm assembly. Verify that the wall structure is adequate for the load.
- **Monitor not holding position:** The gas spring tension may need adjustment. Refer to the specific instructions in your hardware manual for adjusting the tension screw to match your monitor's weight.
- **Keyboard tray or mouse pad is stiff:** Check for any obstructions. Ensure the sliding mechanism is clean and free of debris.
- **Cables are snagging:** Re-route cables through the designated cable management channels to prevent interference with moving parts.

If problems persist after attempting these steps, please contact Mount Plus customer support for further assistance.

PRODUCT SPECIFICATIONS

Feature	Specification
Model	MED02
Brand	Mount Plus
Color	White
Material	Aluminum
Item Weight	7.73 Kilograms
Finish Type	Powder Coated
Monitor Screen Size Compatibility	17"-35"
Monitor Weight Capacity	1-10 kg
Keyboard Tray Weight Capacity	0-2 kg
Monitor Tilt Range	+25° to -3°
Monitor Swivel Range	+/-90°
Special Features	Large Integrated Sliding Mouse Pad, Foldable Keyboard Tray, Adjustable Gas Spring Monitor Arm, Convenient Scanner Access

WARRANTY AND SUPPORT

The Mount Plus MED02 Medical Wall Mount Workstation comes with a **2-year warranty**. This warranty covers manufacturing defects and ensures the product meets quality standards under normal use.

For technical support, warranty claims, or any questions regarding your product, please contact Mount Plus customer service. Refer to the contact information provided with your purchase documentation or visit the official Mount Plus website for support details.