



**Manuals.plus /**

› **Alpicool /**

› Alpicool Portable Refrigerator for Car, 12 Volt Refrigerator with Wheel 42 Quarts Car Refrigerator Dual Zone Independent Control, Portable Car Fridge 12V/24V Electric Cooler for Camping 42QT

## **Alpicool ZGW41**

# **Alpicool Portable Refrigerator User Manual**

Model: ZGW41

## **INTRODUCTION**

---

The Alpicool ZGW41 Portable Refrigerator is designed for versatile use, offering both refrigeration and freezing capabilities with independent temperature control. Its robust design, featuring retractable handles and durable off-road wheels, makes it an ideal companion for camping, road trips, and other outdoor adventures. This manual provides essential information for setting up, operating, maintaining, and troubleshooting your portable refrigerator to ensure optimal performance and longevity.



*The Alpicool ZGW41 Portable Refrigerator, showcasing its spacious interior filled with beverages and fresh produce.*

## WHAT'S IN THE BOX

Your Alpicool Portable Refrigerator package includes the following items:

- 42 Quarts Portable Refrigerator ZGW41
- User Manual
- 12V / 24V DC Power Cord
- 110V~240V AC Adapter and Power Cord

## SETUP & INITIAL USE

### Power Connections

The Alpicool ZGW41 offers flexible power options to suit various needs. It can be powered by 110/240V AC for home or standard outlets, 12V/24V DC for vehicle use, or through solar panels connected to a portable power station for off-grid applications.

# 42 QUART LARGE CAPACITY

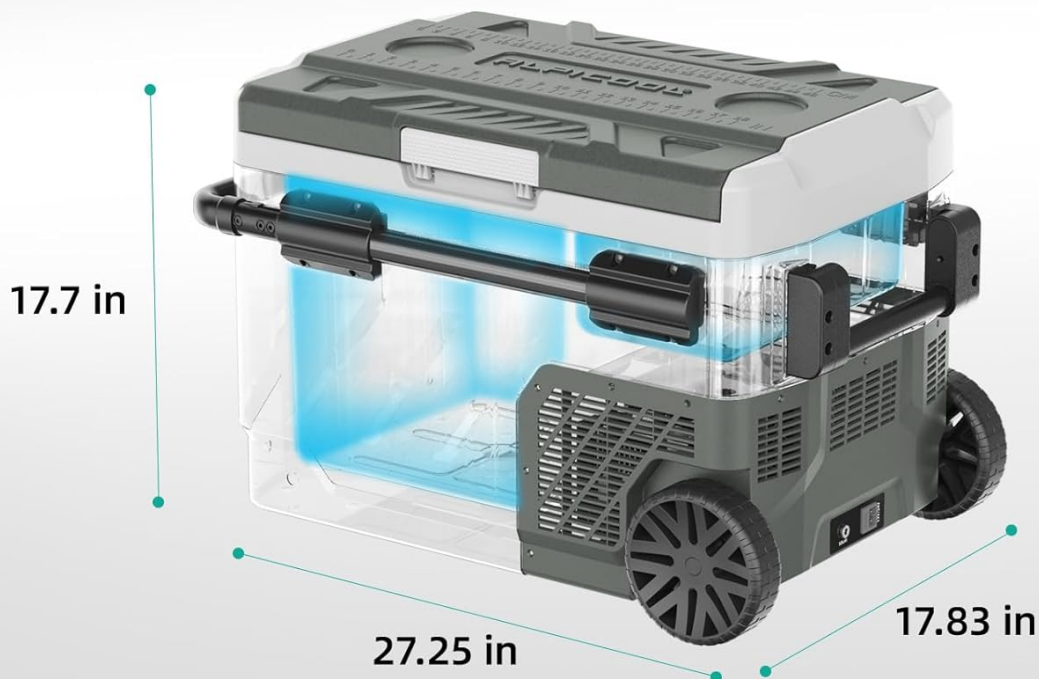

**x 48** Can  
12FL OZ  
355ml

**x 45** Bottle  
16.9FL OZ  
500ml

**x 9** Bottle  
25.36FL OZ  
750ml

*The refrigerator supports both AC and DC power inputs for versatile use.*

### Handle and Wheel Assembly

The portable refrigerator features retractable handles and durable off-road wheels for effortless portability. To extend the handle, press the release buttons on both sides and pull the handle upwards. Ensure it locks securely into place before moving the unit.

# TWO WAYS OF POWER SUPPLY



AC POWER



DC POWER

*The retractable handle and robust wheels facilitate easy transport of the unit.*

## Two-Way Door Functionality

The removable lid is designed to change opening directions based on your preference, providing convenient access to food and drinks. To reverse the lid, open it to a 90-degree angle, pull it up to detach, and then re-install it on the opposite side at the same 90-degree angle until it clicks into place.

# EASY TO CARRY



Retractable Handle



Off-road Wheels



Cup Slot

*The detachable two-way door allows for flexible opening directions.*

## Product Overview Video

Your browser does not support the video tag.

*This video provides a comprehensive overview of the Alpicool portable refrigerator, demonstrating its features and practical use over one month.*

Your browser does not support the video tag.

*Watch this video for detailed testing and an overview of the ZGW Series, highlighting its performance and design.*

## OPERATING INSTRUCTIONS

### Digital Display and Temperature Control

The unit features an LED HD display with temperature memory. It allows independent temperature control for its

dual zones, ranging from 68°F to -4°F. You can set one side as a fridge and the other as a freezer, or use both for the same purpose. Use the '+' and '-' buttons to adjust temperatures. The display also shows battery voltage and current mode (ECO/MAX).

# LED HD DISPLAY SCREEN

## With temperature memory

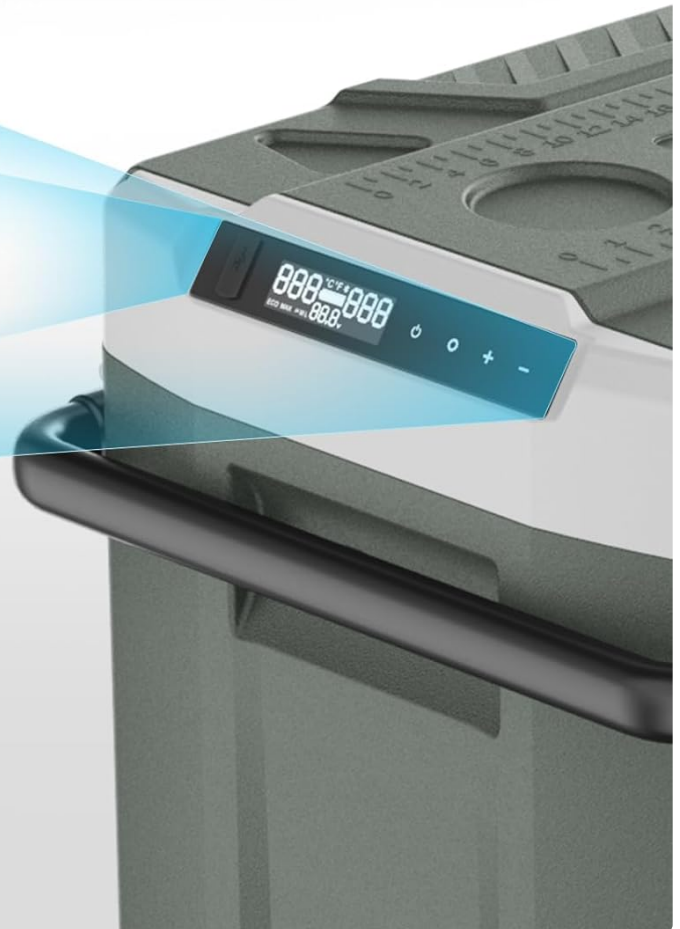

**USB CHARGING PORT**

*The intuitive LED HD display provides clear temperature readings and control options.*

# DUAL ZONE

## Independent Temperature Control

### 4 Different Options

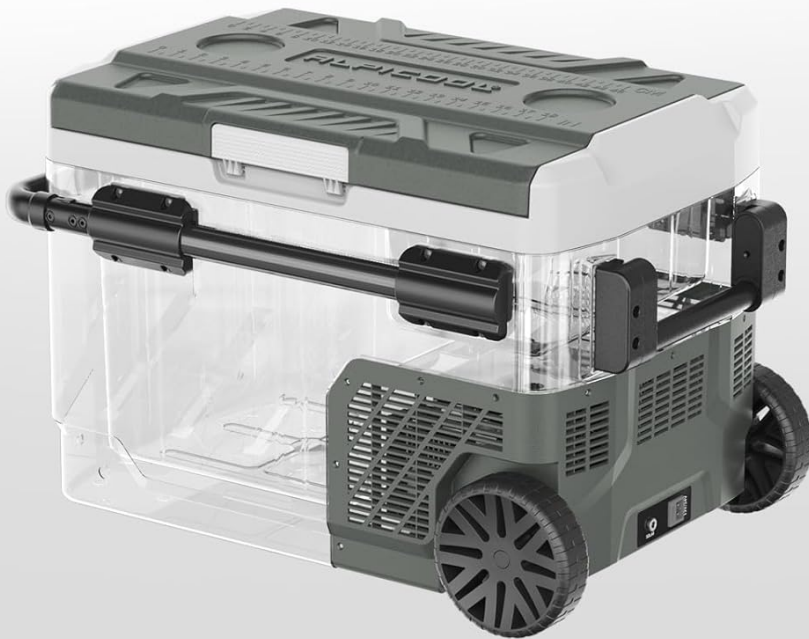

*Independent temperature control allows for flexible use of dual zones as fridge or freezer.*

Choose between ECO mode (45W) for energy saving or MAX mode (60W) for quick cooling. The unit can cool to 32°F within 15 minutes and reach -4°F within 50 minutes.

# POWERFUL & EFFICIENT

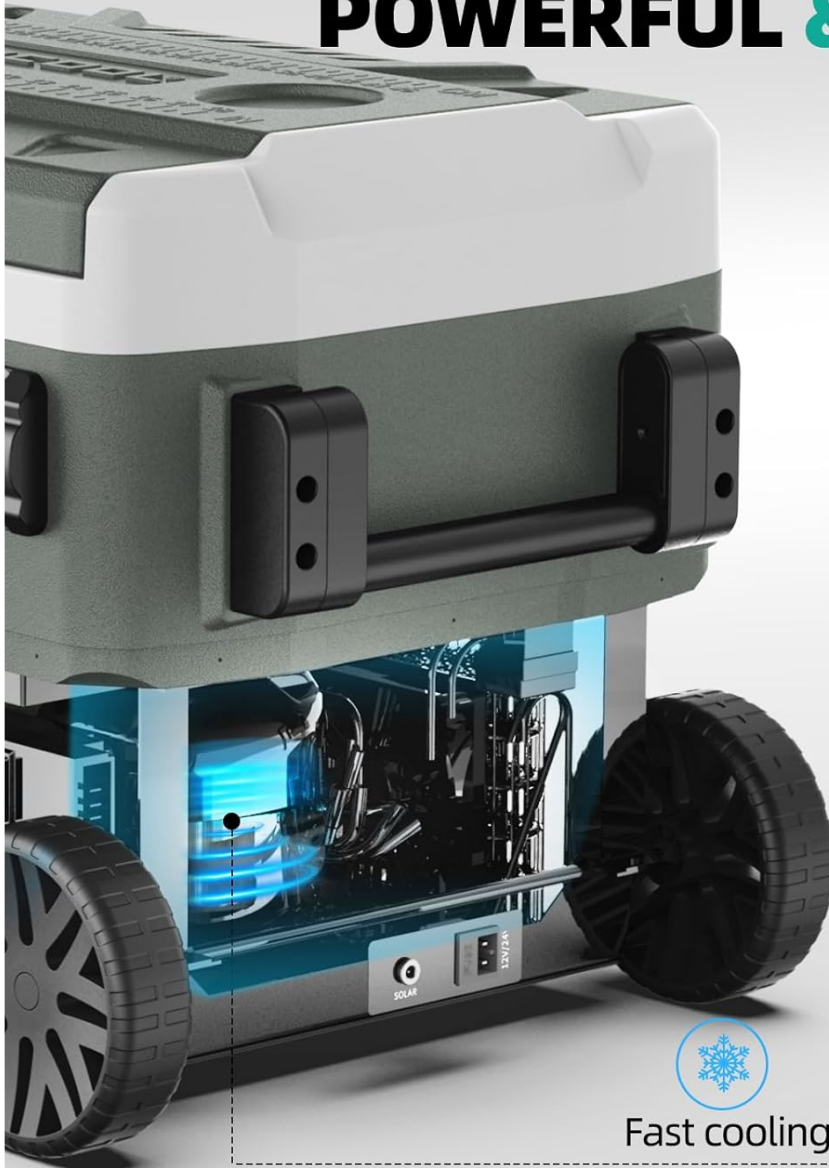

Powerful Compressor



High Quality



45dB Low Noise



Energy Saving



Fast cooling

*The powerful compressor ensures efficient and quiet operation.*

## Battery Protection

The refrigerator features three levels of battery voltage protection (H/M/L) to prevent draining your vehicle's battery. The system automatically stops operation when it detects low battery voltage, ensuring your vehicle can start.

# TWO WAY DOOR

Deattachable design allows you to install the door at either side for more convenience



*Three levels of battery protection safeguard your vehicle's power source.*

## MAINTENANCE

To ensure the longevity and efficient operation of your Alpicool Portable Refrigerator, regular cleaning and proper storage are recommended. The unit features a drain plug for easy cleaning. Simply unscrew the cap at the bottom to drain any accumulated water or for thorough rinsing.

After each use, especially when storing for extended periods, ensure the interior is dry to prevent mold or odors. Wipe down surfaces with a damp cloth and mild detergent, then dry thoroughly before closing the lid.

## TROUBLESHOOTING

If you encounter any issues with your Alpicool Portable Refrigerator, please refer to the common problems and solutions below. For persistent issues, contact customer support.

- **Unit Not Powering On:** Check all power connections (AC/DC cords) to ensure they are securely plugged in. Verify the power source is active. If using DC power, check your vehicle's battery voltage and the battery protection level setting on the unit.
- **Temperature Discrepancies:** The internal temperature displayed may vary slightly from the set temperature, especially during initial cooling or frequent opening. Ensure the lid is properly sealed. Avoid placing hot items directly into the unit. For precise temperature calibration, refer to the detailed instructions in the full user manual.
- **Excessive Noise:** While the unit operates quietly (under 45dB), unusual loud noises might indicate an issue. Ensure the unit is placed on a stable, flat surface and that the ventilation grilles are not obstructed. Clean any dust or debris from the fan area.
- **Inadequate Cooling:** Check that the unit is set to the desired temperature and mode (MAX for faster cooling). Ensure there is sufficient space around the unit for proper ventilation. Avoid overfilling the compartments, which can restrict airflow.

## PRODUCT SPECIFICATIONS

Specification	Detail
Brand Name	Alpicool
Model Info	ZGW41
Item Weight	36.6 Pounds
Product Dimensions	27.25 x 17.83 x 17.7 inches
Capacity	42 Quarts (40 Liters)
Voltage	12V / 24V DC, 110V~240V AC
Special Features	Energy Efficient, Portable, App Control, Large Capacity, Low Noise
Defrost System	Frost Free
Material Type	High Density Polyethylene (HDPE)
Color	Green

## WARRANTY & SUPPORT

---

Alpicool provides a 3-year warranty for the compressor and a 1-year warranty for all other accessories. This warranty covers defects in materials and workmanship under normal use.

For any further questions related to your Alpicool 12V refrigerator, technical assistance, or after-sale service, please feel free to contact our professional support team. Contact details can typically be found on the Alpicool official website or through your purchase platform.