

[Manuals.plus](#) /

› [FEUNGSAKE](#) /

› FEUNGSAKE Laser Engraver and Cutter Machine User Manual

FEUNGSAKE LA5112

FEUNGSAKE Laser Engraver and Cutter Machine User Manual

Model: LA5112

INTRODUCTION

This user manual provides essential information for the safe and efficient operation of your FEUNGSAKE Laser Engraver and Cutter Machine, Model LA5112. Please read this manual thoroughly before assembly, operation, or maintenance to ensure proper use and to prevent damage or injury. This machine is designed for precision engraving and cutting on various materials including wood, metal, glass, and plastic.

PRODUCT OVERVIEW

The FEUNGSAKE Laser Engraver and Cutter Machine features a robust 2040 aluminum frame, ensuring stability and high working accuracy. This model is provided without a control board or laser module, allowing for customization with your preferred components. Its design supports a working area of 20.07 inches by 47.24 inches (510mm x 1200mm).



Figure 1: Overview of the FEUNGSMAKE Laser Engraver Machine frame. This image displays the sturdy 2040 aluminum frame, which forms the base structure of the engraving and cutting machine. It highlights the open design, ready for the integration of a laser module and control board.

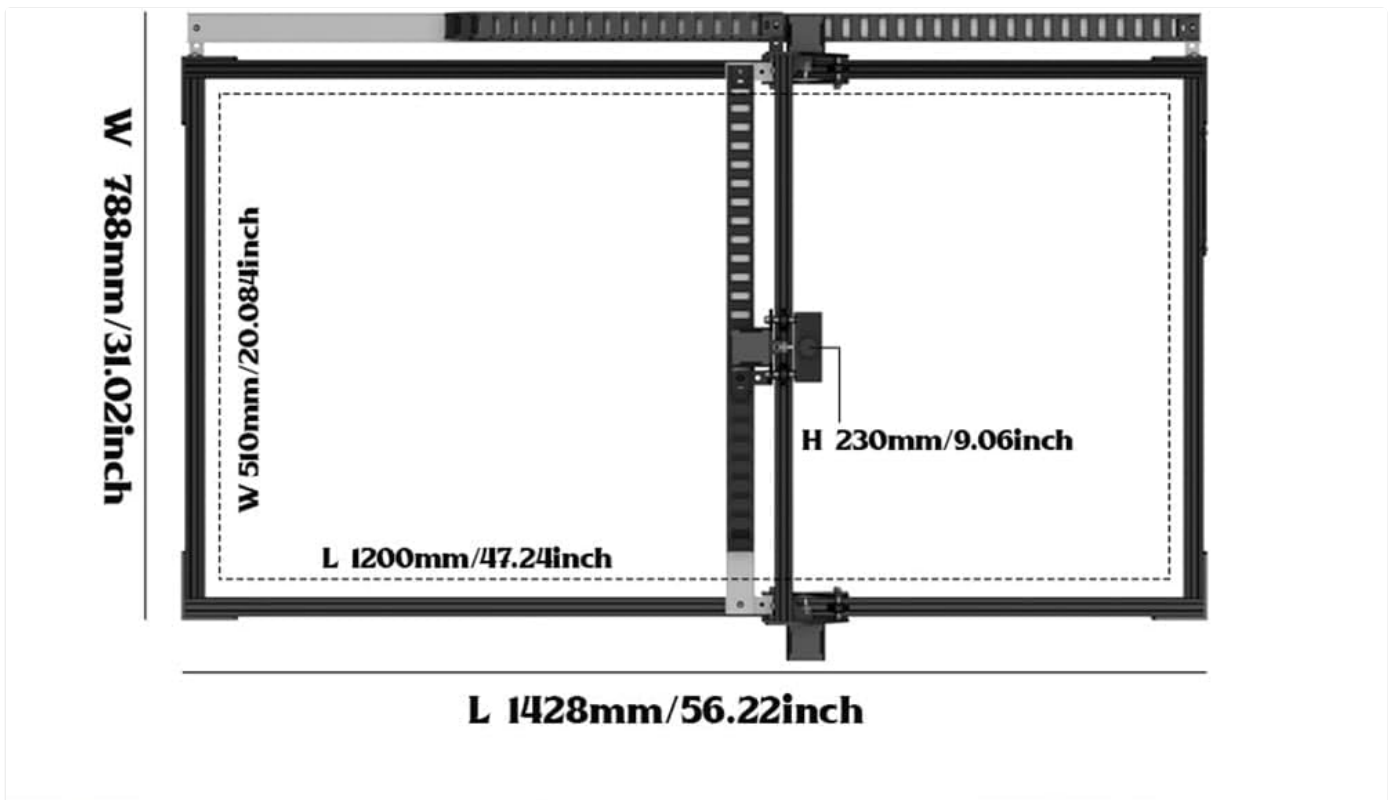

Product name: Laser engraver	Product Series: 5112	Engraving area: 510x1200mm	materials: Aluminum	Package weight: 10kg±1
Adapter: 12v 5A	Package Size: 146*30*13cm	Customize size: Yes Less 2400mm	Customize size: Yes	Operation software: LaserGRBL/ LightBurn/others

Figure 2: Detailed dimensions of the FEUNGSACE Laser Engraver Machine. This diagram illustrates the overall length (L) of 1428mm (56.22 inches), width (W) of 788mm (31.02 inches), and height (H) of 230mm (9.06 inches). The engraving area is specified as 510mm x 1200mm (20.08 inches x 47.24 inches).

PACKING LIST

Upon unpacking, please verify that all components listed below are present and undamaged. If any items are missing or damaged, contact customer support immediately.

Packing List



Figure 3: Contents of the FEUNGSKE Laser Engraver Machine package. This image displays all the components included in the box, such as aluminum profiles, various cables, motors, brackets, power adapter, safety glasses, and hardware for assembly.

- Aluminum Frame Profiles (2040 type)
- X-axis and Y-axis Motor Assemblies
- Power Adapter (12V 5A)
- Cables and Wiring Harnesses
- Mounting Brackets and Hardware (screws, nuts, washers)
- Timing Belts and Pulleys
- Cable Chains
- Wrench and other basic tools
- Safety Glasses
- User Manual (this document)

Note: This package does not include a laser module or a control board. These components must be purchased separately.

SETUP AND ASSEMBLY

Follow these steps carefully for the assembly of your laser engraver frame. Ensure you have a clean, flat, and stable workspace.

1. **Frame Assembly:** Connect the 2040 aluminum profiles to form the rectangular frame. Use the provided corner brackets and screws to secure all joints. Ensure all connections are tight and the frame is square.
2. **Axis Installation:** Install the X-axis and Y-axis motor assemblies onto the frame. The Y-axis uses dual motors for

powerful and stable movement.

- Belt and Pulley Installation:** Route the timing belts around the pulleys and secure them. Ensure proper tension to prevent slippage during operation.
- Cable Management:** Use the provided cable chains to neatly route all wiring, preventing interference with moving parts.
- Power Connection:** Connect the 12V 5A power adapter to the machine.
- Laser Module and Control Board (Sold Separately):** Install your chosen laser module and control board according to their respective manuals. Ensure compatibility with the machine's frame and motor systems.

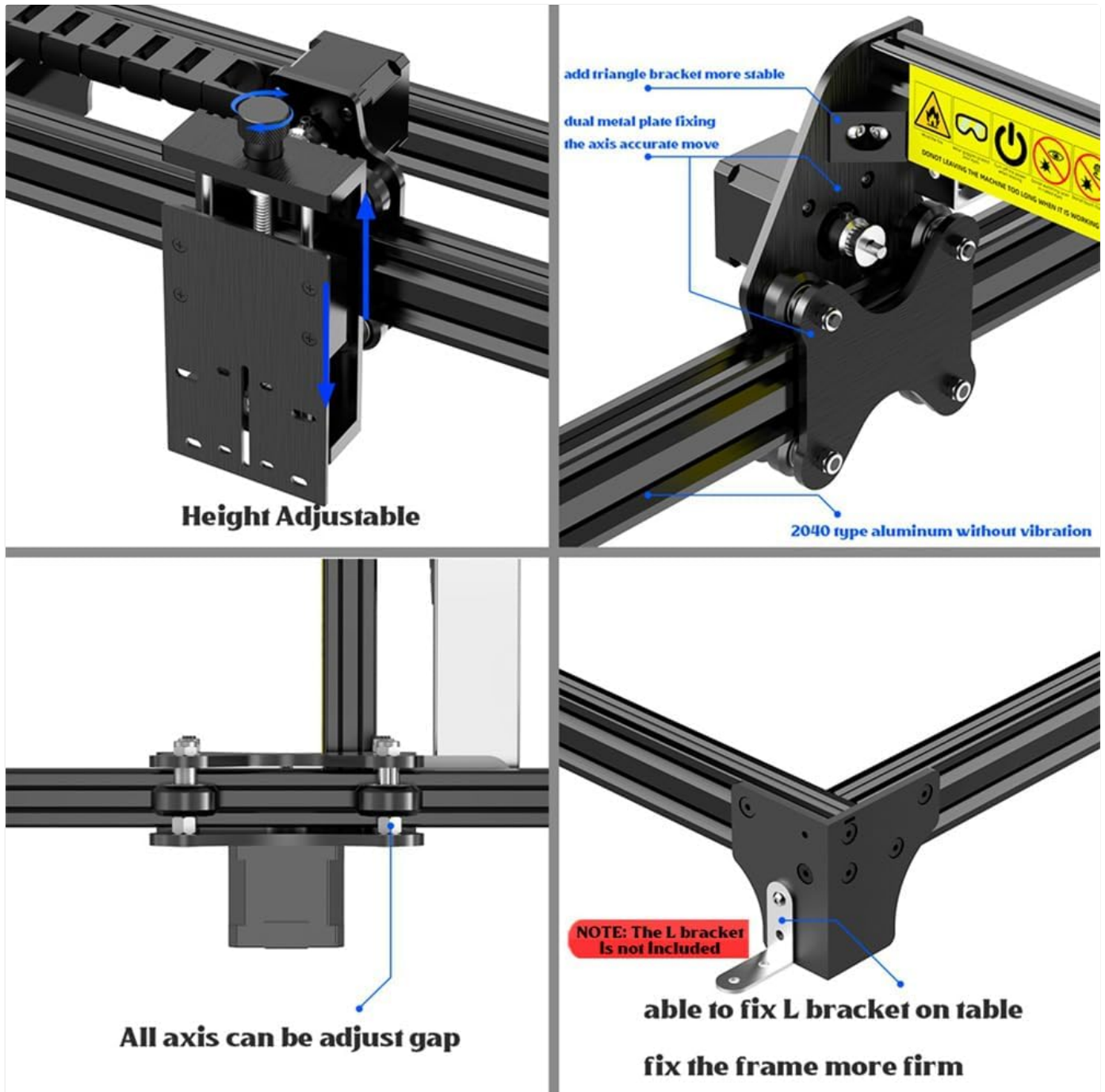

Figure 4: Key assembly and structural details of the FEUNGSAKE Laser Engraver. This image highlights features such as the height-adjustable laser mount, the ability to adjust gaps on all axes for precision, the robust 2040 type aluminum frame designed to minimize vibration, and the option to fix the L-bracket to a table for enhanced stability.

The machine's frame is constructed from 2040 aluminum, known for its stability. The accuracy difference of aluminum V-slot is less than 0.04mm, contributing to high working accuracy. The axis pulley clearance can be adjusted for optimal performance.

OPERATING INSTRUCTIONS

This section outlines general operating principles. Specific software instructions will depend on your chosen control board and software (e.g., LaserGRBL, LightBurn).

- Software Installation:** Install the appropriate engraving software on your computer.
- Connect Machine:** Connect the machine to your computer via USB (if applicable to your control board).
- Material Placement:** Place the material to be engraved or cut securely on the working surface.
- Focus Adjustment:** Adjust the height of your laser module to achieve the correct focal distance for your material. The laser mount allows for precise up and down adjustment.
- Parameter Settings:** In your software, set the engraving/cutting parameters (power, speed, passes) according to the material type and desired outcome. The machine supports working speeds up to 20000mm/min. For speeds above 15000mm/min, the stable frame ensures no shaking.
- Start Operation:** Initiate the engraving or cutting process from your software.
- Monitoring:** Always monitor the machine during operation. Never leave it unattended.

Safety Precaution: Always wear the provided safety glasses when the laser is active. Ensure proper ventilation in your workspace.

MAINTENANCE

Regular maintenance ensures the longevity and optimal performance of your machine.

- Cleaning:** Regularly clean the aluminum profiles, belts, and pulleys to remove dust and debris. Use a soft cloth.
- Lubrication:** Apply a small amount of lubricant to the linear rails and lead screws (if applicable to your setup) periodically to ensure smooth movement.
- Belt Tension:** Check the tension of the timing belts. Adjust if they are too loose or too tight.
- Fastener Check:** Periodically inspect all screws and fasteners to ensure they are tight. Re-tighten as necessary.
- Cable Inspection:** Check all cables for signs of wear or damage. Replace any damaged cables immediately.

TROUBLESHOOTING

This section addresses common issues. For more complex problems, consult your control board and laser module manuals or contact customer support.

Problem	Possible Cause	Solution
Machine not responding	Power issue, loose connection, software error	Check power adapter, ensure all cables are securely connected, restart software and computer.
Inaccurate engraving/cutting	Loose belts, incorrect focus, unstable frame, software settings	Check and adjust belt tension, re-focus laser, ensure frame is stable, verify software parameters.
Motor skipping steps	Overload, insufficient current, mechanical obstruction	Reduce engraving speed/power, check motor driver settings, clear any obstructions on rails.

SPECIFICATIONS

Feature	Detail
---------	--------

Feature	Detail
Model Number	LA5112
Frame Material	2040 Aluminum
Input Voltage	110V-230V (via 12V 5A adapter)
Working Speed (Acceptable)	0-20000 mm/min
Working Area (Customizable)	510mm x 1200mm (20.07" x 47.24")
Product Dimensions (Assembled)	57.48 x 11.81 x 5.11 inches (approx. 1460 x 300 x 130 mm)
Manufacturer	FEUNGSAKE

WARRANTY AND SUPPORT

For warranty information and technical support, please refer to the documentation provided with your specific control board and laser module, as this product is sold as a frame kit without these components. For issues related to the frame structure or missing parts from the original package, please contact FEUNGSAKE customer service through your purchase platform.

Contact Information: Please refer to your purchase receipt or the seller's information on the platform where you purchased this product for direct contact details.