

## Topyond XKC C352 3P

# Topyond Water Level Controller User Manual

Model: XKC C352 3P

## 1. PRODUCT OVERVIEW

The Topyond AC100-260V Automatic Water Level Controller, model XKC C352 3P, is designed for precise and automatic control of liquid levels in tanks and other containers. It utilizes non-contact liquid level sensors to detect water levels without direct contact, ensuring reliability and hygiene. This controller supports both water inlet detection and overflow detection modes, making it versatile for various applications.



Figure 1: Topyond XKC C352 3P Automatic Water Level Controller with included non-contact sensors and a screwdriver.

## 2. KEY FEATURES

- **Multiple Functions:** Supports both water inlet detection and overflow detection modes, configurable via simple wiring.
- **Reliable Alarm System:** Equipped with low and high-level sensors that trigger alarm codes and control pump operation via a relay to ensure equipment safety.
- **Easy Installation:** Can be installed by twisting or mounted on an electrical box rail, with detailed instructions provided.
- **Wide Load Control:** Features a wide voltage range (AC100-260V) and relay dry contact output, suitable for controlling various loads like water pumps and other electrical devices.
- **Pump Dry Run Protection:** Includes a protection function to prevent damage to pumps caused by prolonged empty running, extending equipment lifespan.

### 3. SPECIFICATIONS

---

Parameter	Value
Model	XKC C352 3P (fully automatic water level control and inlet or overflow detection)
Input Voltage	AC100V to 260V, 50 or 60Hz
Working Current	Working current $\leq$ 110mA, static current consumption $\leq$ 20mA
Resistive Load Power	Up to 1.6KW (AC contactor required for overload or three-phase loads)
Inductive Load Power	Below 1KW (additional AC contactors required for overload or three-phase loads)
Alarm Output	800W (resistive load) normally open or normally closed output
Output Mode	Normally open or normally closed output
Induction Head Interface Voltage	DC12V
Working Temperature	-20 to 105°C
Dimensions (Controller)	Approx. 115 x 90 x 40mm / 4.53 x 3.54 x 1.57in
Item Weight	10.6 ounces

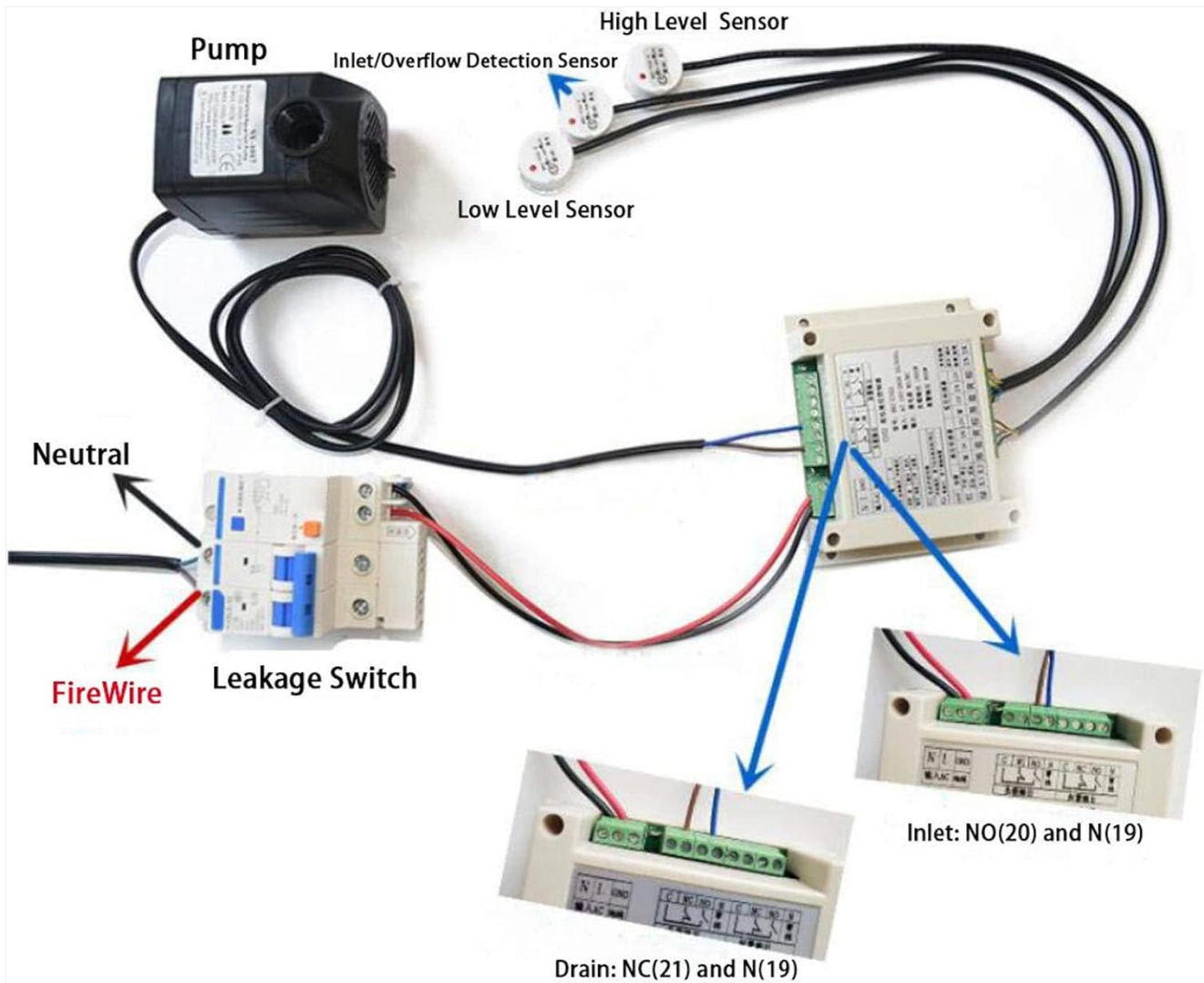

Figure 2: Detailed dimensions of the Topyond Water Level Controller unit.

## 4. PACKAGE CONTENTS

The package includes the following items:

- 1 x Automatic Water Level Controller (XKC C352 3P)
- 1 x Screwdriver
- 3 x Non-contact liquid level sensors (integrated with the controller)

## 5. SAFETY INFORMATION AND IMPORTANT NOTES

**WARNING: This controller requires electrical engineering skills for proper installation and operation. If you are not proficient with electrical wiring and safety procedures, it is strongly recommended to seek assistance from a qualified electrician. Improper installation can lead to electric shock, fire, or damage to the equipment.**

- Always disconnect power before performing any installation, wiring, or maintenance.
- Ensure all connections are secure and properly insulated.
- Do not exceed the specified load capacities for resistive and inductive loads. Use an AC contactor for loads exceeding specifications or for three-phase loads.
- Operate within the specified working temperature range.

## 6. SETUP AND INSTALLATION

The Topyond Water Level Controller can be installed by twisting or mounted on an electrical box rail. Follow the wiring diagrams carefully for correct setup.

### 6.1 Wiring Diagram Overview

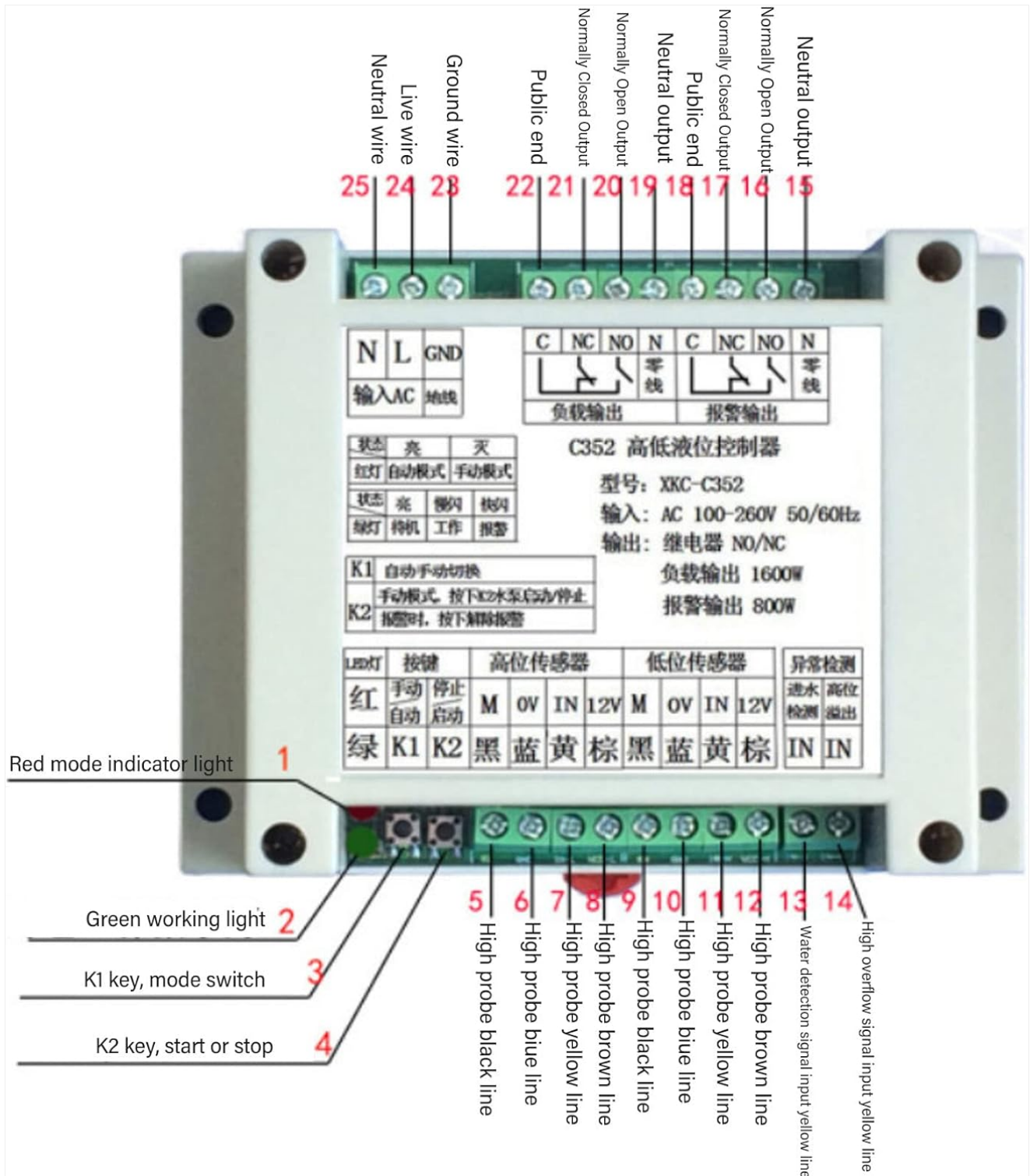
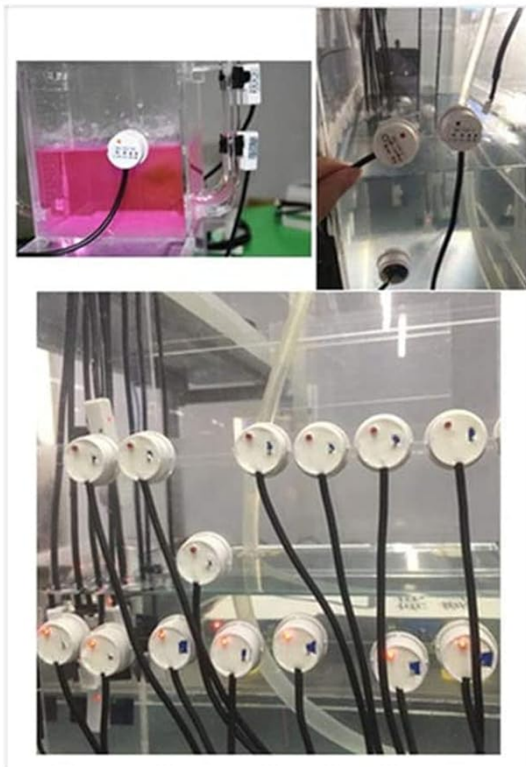

Figure 3: General wiring diagram showing connections between the controller, pump, leakage switch, and sensors.

### 6.2 Detailed Wiring and Terminal Identification

Refer to the detailed diagram below for terminal identification and sensor connections. The controller features clearly labeled terminals for input power, load output, alarm output, and sensor connections.

# Industry Comparison



VS

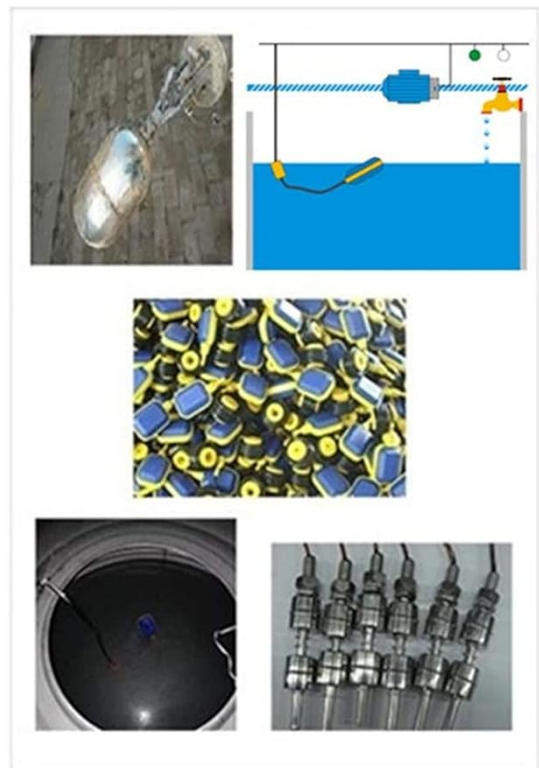

## Non-contact liquid level sensor:

No needs to contact with liquid, easy to install;  
IP67 protection and waterproof, more durable;  
Suitable for a wide range of container applications.

## Floats:

Can not be detected from the outside;  
Easy to rust, short service life;  
Affect water quality;  
Harsh application conditions;  
High cost.

Figure 4: Detailed view of the controller's terminals and sensor wire connections. Note the K1 and K2 switches for mode selection and start/stop control.

- **Power Input (N, L, GND):** Connect AC100-260V power supply.
- **Load Output (C, NO, NC):** Connect your pump or other load here.
  - Normally Open (NO) and Neutral (N) for water inlet control.
  - Normally Closed (NC) and Neutral (N) for overflow control.
- **Alarm Output (C, NO, NC):** For connecting an external alarm device.
- **Sensor Connections:** The three non-contact sensors connect to the dedicated terminals. Each sensor has specific wire colors (black, yellow, brown, blue) that correspond to the controller's input terminals (M, 0V, 12V, IN).
- **K1 Switch:** Mode selection (automatic/manual).
- **K2 Switch:** Start/Stop control.
- **Red LED:** Mode indicator light.
- **Green LED:** Working light.

Ensure the sensors are mounted correctly on the outside of the tank at the desired high and low-level detection

points. The non-contact design allows for easy installation without modifying the tank.

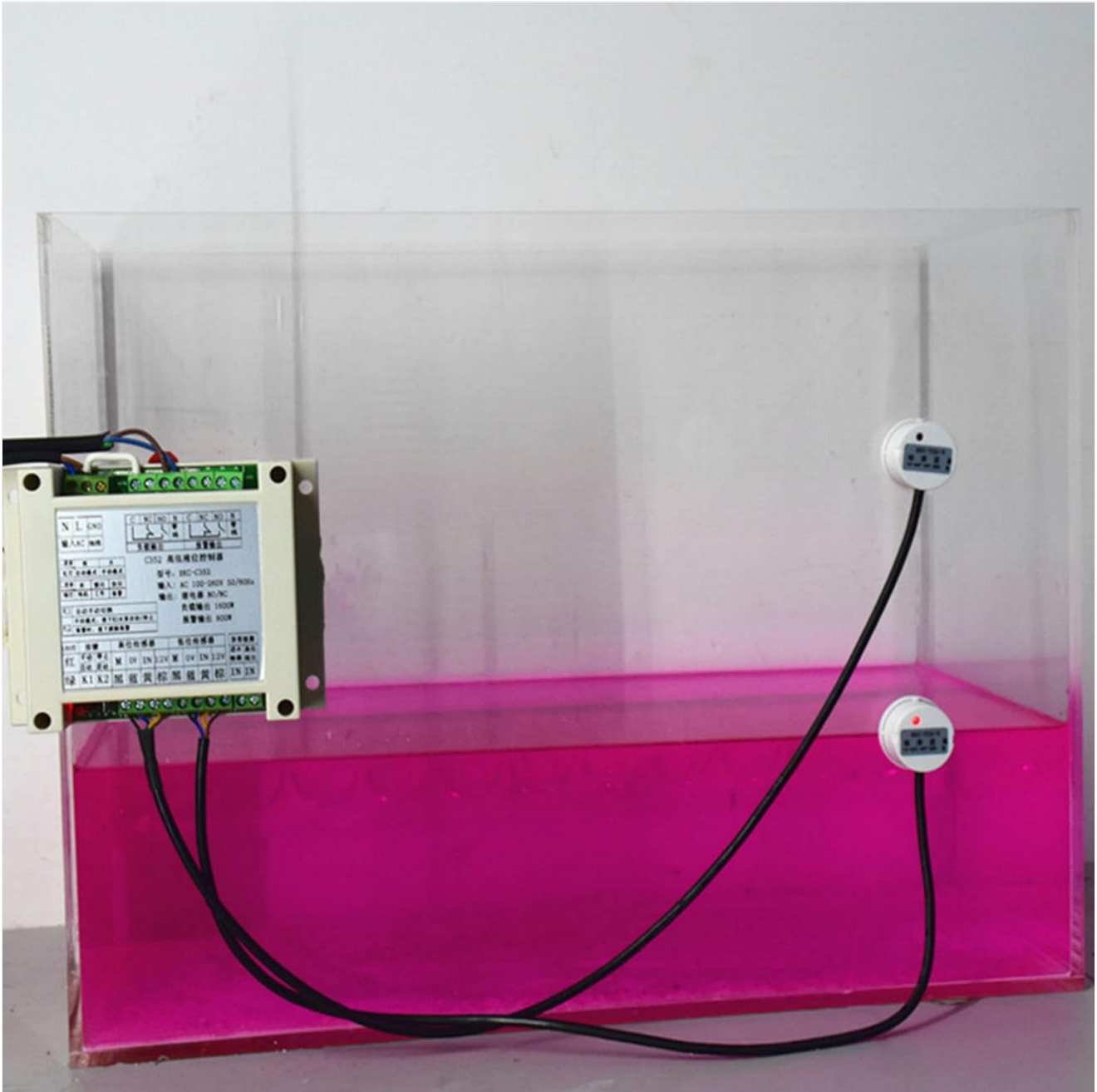

Figure 5: Example setup showing the controller and sensors mounted on a clear tank.

## 7. OPERATING INSTRUCTIONS

---

The XKC C352 3P controller offers flexible operation modes for automatic water level management.

### 7.1 Mode Selection (K1 Switch)

- **Automatic Mode:** The controller will automatically manage the water level based on the sensor readings. This is the primary mode for continuous operation.
- **Manual Mode:** Allows for manual control of the connected pump or device using the K2 switch.

### 7.2 Water Inlet Detection Mode

In this mode, the controller will activate the pump (or open a valve) to fill the tank when the water level drops below the low-level sensor. It will deactivate the pump when the water reaches the high-level sensor. This is ideal for automatic water replenishment systems.

### **7.3 Overflow Detection Mode**

In this mode, the controller will activate the pump (or open a drain valve) to empty the tank when the water level rises above the high-level sensor. It will deactivate the pump when the water drops below the low-level sensor. This is suitable for preventing overflows or managing drainage.

### **7.4 Alarm System**

The controller is equipped with an alarm system. When the liquid level is too low or too high, the corresponding alarm code will be triggered. The controller's relay output can be used to activate an external alarm device or signal system.

### **7.5 Pump Dry Run Protection**

This feature protects your pump from damage by preventing it from running when there is no water to pump. The controller will detect a dry run condition and stop the pump, extending its operational life.

## **8. APPLICATIONS**

---

The Topyond Water Level Controller is suitable for a wide range of applications requiring automatic liquid level management.

# Application



**Intelligent Water Supply  
for Water Tower and Tank**



**Live Water Treatment  
for Fish Tank**



**Sewage Treatment**



**Intelligent Boiler Water  
Supplement**

Figure 6: Examples of applications including intelligent water supply systems for agricultural irrigation and water supply for various industrial equipment.

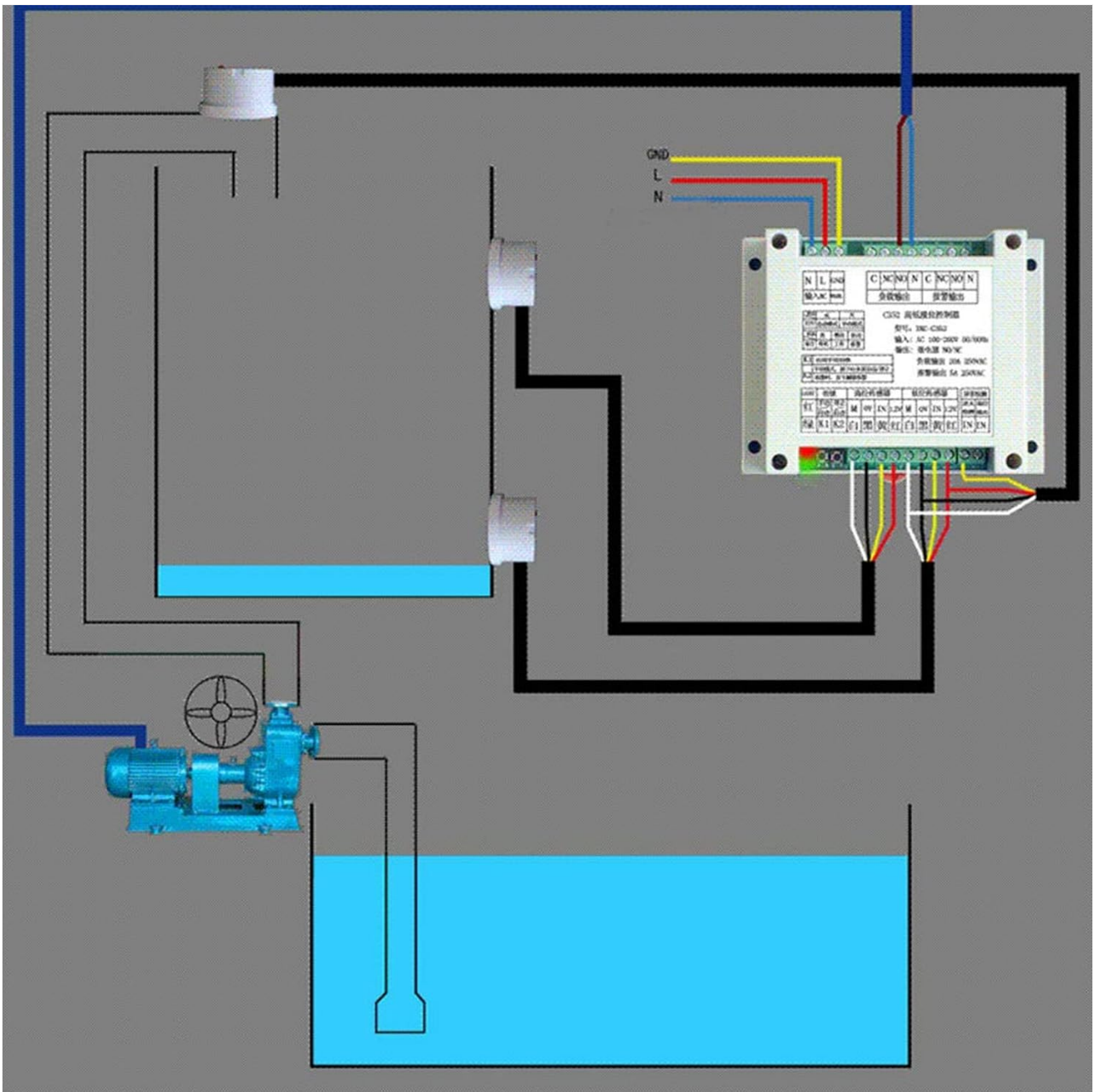

Figure 7: Additional applications such as intelligent water supply for water towers and tanks, live water treatment for fish tanks, sewage treatment, and intelligent boiler water supplement systems.

### 8.1 Non-Contact Sensor Advantages

The non-contact liquid level sensors offer significant advantages over traditional float-type sensors:



**Intelligent Water Supply System for Agricultural Irrigation**



**Water Supply for Other Equipment**



Figure 8: Comparison highlighting the benefits of non-contact sensors over traditional float sensors.

- No direct contact with liquid, preventing corrosion and contamination.
- Easy to install externally, no need to modify the container.
- IP67 protection and waterproof, ensuring durability.
- Suitable for a wide range of container applications.
- Avoids issues like rusting, short service life, and water quality impact associated with floats.

## 9. TROUBLESHOOTING

If you encounter issues with your Topyond Water Level Controller, consider the following common troubleshooting steps:

- **No Power:** Check the AC100-260V power input connections. Ensure the power source is active.
- **Pump Not Activating/Deactivating:**
  - Verify sensor placement and ensure they are correctly detecting the liquid levels.

- Check wiring to the pump and ensure it matches the selected operating mode (inlet/overflow).
  - Confirm the K1 switch is in the correct automatic mode.
  - Ensure the load (pump) does not exceed the controller's specified power limits. An AC contactor may be required for larger loads.
- **Inaccurate Level Detection:**
    - Ensure sensors are clean and free from obstructions on the tank surface.
    - Verify sensors are securely mounted and not shifting.
  - **Alarm Not Triggering:** Check the wiring to the external alarm device. Ensure the alarm output mode is correctly configured.
  - **Controller Malfunction:** If the controller exhibits unusual behavior, disconnect power, wait a few minutes, and then reconnect. If the issue persists, contact customer support.

## 10. MAINTENANCE

---

The Topyond Water Level Controller is designed for low maintenance. However, regular checks can ensure optimal performance and longevity:

- **Sensor Cleaning:** Periodically inspect the non-contact sensors for any dirt or residue on the tank surface where they are mounted. Clean as necessary to ensure accurate readings.
- **Wiring Inspection:** Annually check all electrical connections for tightness and signs of wear or corrosion.
- **Environmental Conditions:** Ensure the controller is operating within its specified temperature range (-20 to 105°C) and is protected from excessive moisture or direct sunlight.
- **Firmware (if applicable):** No user-upgradable firmware is mentioned.

Always disconnect power before performing any maintenance.

## 11. WARRANTY AND SUPPORT

---

For warranty information and technical support, please refer to the documentation provided with your purchase or contact Topyond customer service through their official channels. Keep your purchase receipt as proof of purchase for warranty claims.

For further assistance, visit the [Topyond Store on Amazon](#).