

Manuals+

[Q & A](#) | [Deep Search](#) | [Upload](#)

[manuals.plus](#) /

› [LIFEZEAL](#) /

› [LIFEZEAL 3-in-1 Kids Wooden Art and Activity Table Set Instruction Manual \(Model PG98021\)](#)

LIFEZEAL PG98021

LIFEZEAL 3-in-1 Kids Wooden Art and Activity Table Set

Model: PG98021

INTRODUCTION

Thank you for choosing the LIFEZEAL 3-in-1 Kids Wooden Art and Activity Table Set. This versatile furniture set is designed to provide a dedicated space for children's learning, creativity, and play. It functions as a learning table, an art easel, and a craft table, complete with integrated storage solutions. This manual provides essential information for assembly, safe operation, and maintenance of your new product.



Image: The complete LIFEZEAL 3-in-1 Kids Wooden Art and Activity Table Set, featuring a white wooden table with integrated storage shelves and two matching chairs.

SAFETY INFORMATION

Please read and understand all safety warnings before assembling and using this product. Failure to follow these instructions may result in injury or damage.

- **Assembly:** Ensure all assembly instructions are followed precisely for safe and stable use.
- **Weight Capacity:** Do not overload the table or chairs. The maximum load capacity for the table is 91 kg (200 lbs), and for each chair is 75 kg (165 lbs).
- **Child Safety:** The table features rounded corners to minimize the risk of injury from accidental bumps. Always supervise children during use.
- **Stability:** Place the furniture on a flat, stable surface to prevent tipping.
- **Small Parts:** Keep small parts and assembly hardware away from young children before and during assembly to prevent choking hazards.

PACKAGE CONTENTS

Verify that all components are present before beginning assembly:

- 1 x Art Table and Chair Set (includes table and 2 chairs)
- 6 x Storage Boxes (fabric, removable)
- 4 x Paint Cups
- 1 x Paper Roll
- 1 x Multilingual User Manual (this document)
- Required Assembly Hardware (screws, connectors, etc.)

SETUP AND ASSEMBLY

Assembly is required for this product. Please refer to the separate detailed assembly instructions included in your package for step-by-step guidance. Ensure you have adequate space and the necessary tools (e.g., screwdriver) before starting.

Product Dimension

Suitable for 3+ Years Old

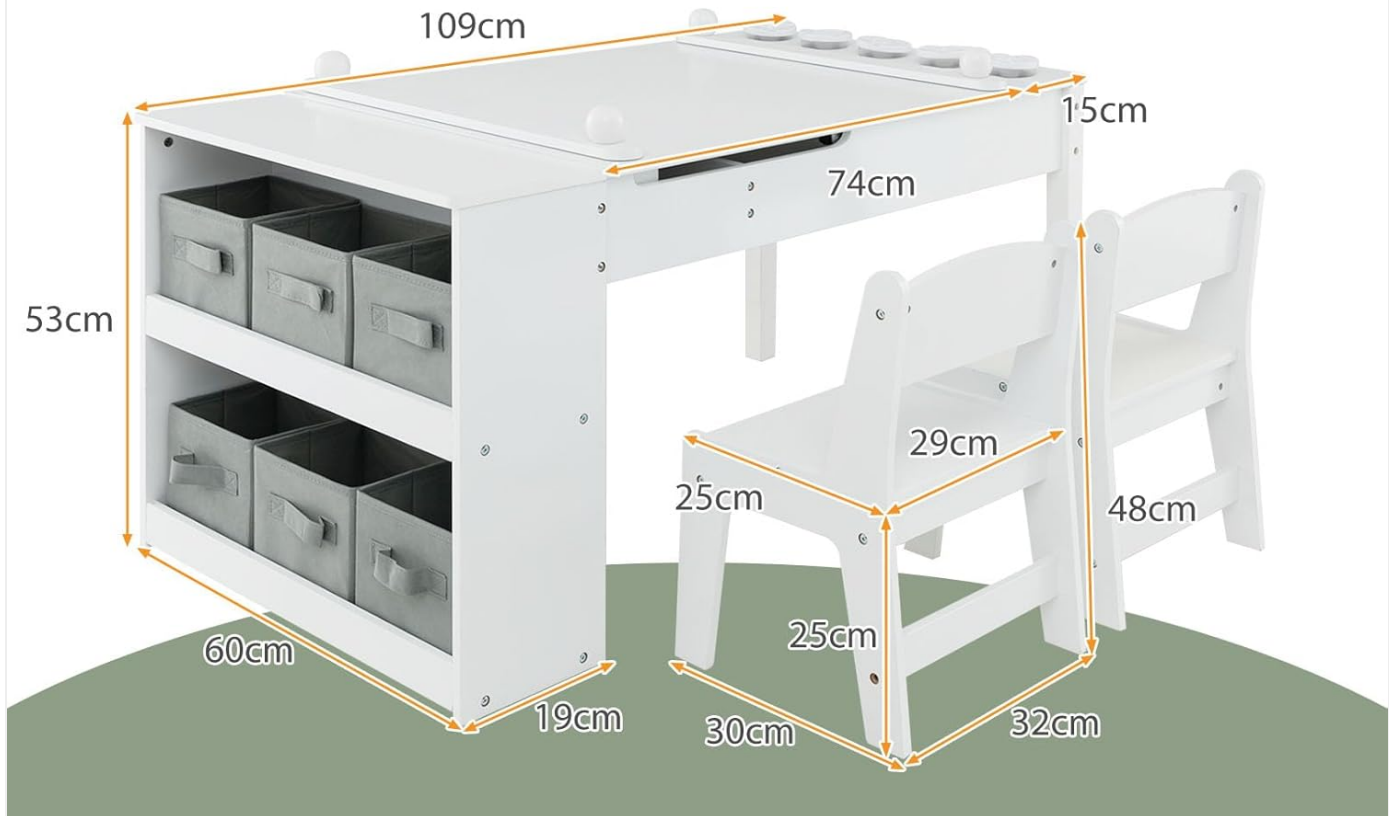

Image: A diagram illustrating the dimensions of the table (109cm L x 60cm W x 53cm H), chairs (29cm L x 29cm W x 48cm H), storage boxes (15cm L x 15cm W x 18cm H), and paint cups (8cm diameter x 8.5cm H). This image is useful for planning the setup space.

Key Assembly Tips:

- Identify all parts and hardware before assembly.
- Follow the numerical or alphabetical order of steps in the assembly manual.
- Do not overtighten screws to avoid damaging the wood.
- Ensure all connections are secure before use.

OPERATING INSTRUCTIONS

3-in-1 Functionality

This versatile set offers three primary modes of use:

- **Learning Table:** Use the flat tabletop for reading, writing, puzzles, or other educational activities.
- **Art Easel:** The tabletop can be lifted and secured in an upright position to function as an easel. This is ideal for

drawing, painting, or displaying artwork. The integrated air rod provides stable support for the lifted tabletop.

- **Craft Table:** The spacious surface and integrated storage make it perfect for various craft projects, providing easy access to materials.

Flip-top Art Table

Can also serve as an art easel



Replaceable Paper Roll Holder
(1 Paper Roll Included)



Anti-Pinch
Cutout Handle



Slow-drop
Pneumatic Rods

Image: A sequence showing the tabletop being lifted to transform into an art easel, highlighting the replaceable paper roll holder, anti-pinch cutout handle, and slow-drop pneumatic rods for safe operation.

Storage Features

The table set includes ample storage to keep art supplies, toys, and books organized:

- **Under-Desktop Storage:** When the tabletop is in the flat position, a roomy compartment underneath provides hidden storage for larger items or works in progress.
- **Two-Tier Open Shelves:** Located on the side of the table, these shelves are designed to hold the six removable fabric storage boxes.
- **Removable Fabric Storage Boxes:** Six grey fabric boxes are included for organizing smaller items like crayons, blocks, or small toys. These boxes can be easily pulled out and moved as needed.
- **Paper Roll Holder:** A dedicated holder for the included paper roll allows for continuous drawing and painting

surfaces.

- **Paint Cups:** Four paint cups are provided for various art mediums.

Abundant Storage Space



Roomy Storage Space
Under the Desktop



2-Tier Open Shelves



6 Removable Fabric
Storage Boxes

Image: A detailed view of the storage features, showing the roomy storage space under the desktop, the two-tier open shelves, and a close-up of the removable fabric storage boxes being used to hold toys.

Perfect Art Center for Kids



Imagination



Creativity



Hands-on Ability

Image: Two young children engaged in creative activities at the LIFEZEAL 3-in-1 Kids Wooden Art and Activity Table, demonstrating its use for imagination, creativity, and hands-on ability.

MAINTENANCE

Proper care will extend the life and appearance of your LIFEZEAL furniture set:

- **Cleaning:** Wipe surfaces with a dry or damp cloth. Avoid abrasive cleaners or harsh chemicals that could damage the finish.
- **Spills:** Clean up spills immediately to prevent staining, especially on the wooden surfaces. The table surface is designed to be easy-to-clean and waterproof.
- **Inspection:** Periodically check all screws and connections to ensure they remain tight. Retighten if necessary.
- **Storage:** Store the furniture in a dry environment, away from extreme temperatures or direct sunlight, to prevent warping or fading.

Kids Art Table & 2 Chairs Set



Image: A composite image highlighting key features: round corners and smooth edges for safety, a fixing rod for the paper roll, an ergonomic backrest on the chairs, and the easy-to-clean waterproof surface of the table.

TROUBLESHOOTING

If you encounter any issues with your LIFEZEAL 3-in-1 Kids Wooden Art and Activity Table Set, please refer to the following general advice:

- **Stability Issues:** Ensure all screws are securely tightened. Check that the furniture is placed on a level surface.
- **Missing Parts:** If any parts are missing upon unboxing, please contact customer support immediately.
- **Damage:** If the product arrives damaged, do not proceed with assembly. Contact customer support for assistance.

For further assistance, please contact LIFEZEAL customer support.

SPECIFICATIONS

Feature	Detail
Brand	LIFEZEAL
Model Number	PG98021
Material	Wood (MDF)
Color	White
Table Dimensions (L x W x H)	109 x 60 x 53 cm (43 x 23.6 x 20.9 inches)
Chair Dimensions (L x W x H)	29 x 29 x 48 cm (11.4 x 11.4 x 18.9 inches)
Storage Box Dimensions (L x W x H)	15.5 x 18 x 18 cm (6.1 x 7.1 x 7.1 inches)
Table Load Capacity	91 kg (200 lbs)
Chair Load Capacity	75 kg (165 lbs)
Net Weight	24 kg (52.9 lbs)
Assembly Required	Yes
Special Feature	Reversible tabletop (easel function)
Care Instructions	Clean with a dry or damp cloth

WARRANTY AND SUPPORT

LIFEZEAL products are manufactured with quality and customer satisfaction in mind. For specific warranty information regarding your 3-in-1 Kids Wooden Art and Activity Table Set, please refer to the warranty card included in your package or visit the official LIFEZEAL website.

If you have any questions, require technical assistance, or need to report a missing/damaged part, please contact LIFEZEAL customer support through the contact information provided on our website or in your product documentation. Please have your model number (PG98021) and purchase details ready when contacting support.

