

[Manuals.plus](#) /

> [MAHANCRIS](#) /

> MAHANCRIS File Cabinet with Charging Station (Model FCHR98E01) User Manual

## MAHANCRIS FCHR98E01

# MAHANCRIS File Cabinet with Charging Station

Model: FCHR98E01 | Brand: MAHANCRIS

## 1. INTRODUCTION

Thank you for choosing the MAHANCRIS File Cabinet with Charging Station. This mobile filing cabinet is designed to enhance your home office or living space with efficient storage and convenient power access. It features three fabric drawers, two open shelves, and a built-in charging station, all on lockable universal wheels for flexible placement.



The MAHANCRIS File Cabinet with Charging Station, shown in a rustic brown finish, provides organized storage and a convenient charging hub for various devices in an office environment.

## 2. SAFETY INFORMATION

---

- Do not wash non-woven fabric drawers.
- Avoid overloading the product beyond its stated weight capacity.
- Keep children away from playing with the unit to prevent accidents.
- Ensure the power cord is not pinched or damaged during assembly or use.

## 3. PACKAGE CONTENTS

---

Please verify that all components are present before beginning assembly:

- 1 x File Cabinet (disassembled components)
- 1 x Power Strip (pre-installed or separate)
- 1 x Accessory Kit (screws, tools, etc.)
- 1 x User Manual (this document)

## 4. SPECIFICATIONS

Feature	Detail
Brand	MAHANCRIS
Model Number	FCHR98E01
Color	Rustic Brown
Material	Engineered Wood, Metal
Product Dimensions (D x W x H)	15"D x 24.4"W x 28.5"H
Item Weight	16.1 Pounds
Weight Capacity (Maximum)	66 Pounds (top surface)
Number of Drawers	3 (Non-woven fabric)
Number of Shelves	2 (Open)
Charging Station	2 AC Outlets (120V/12A), 2 USB Ports (5V/2A)
Power Cord Length	59 inches (approx. 4.9 feet)
Wheels	4 Universal Wheels (2 lockable)
File Compatibility	A4/Letter Size

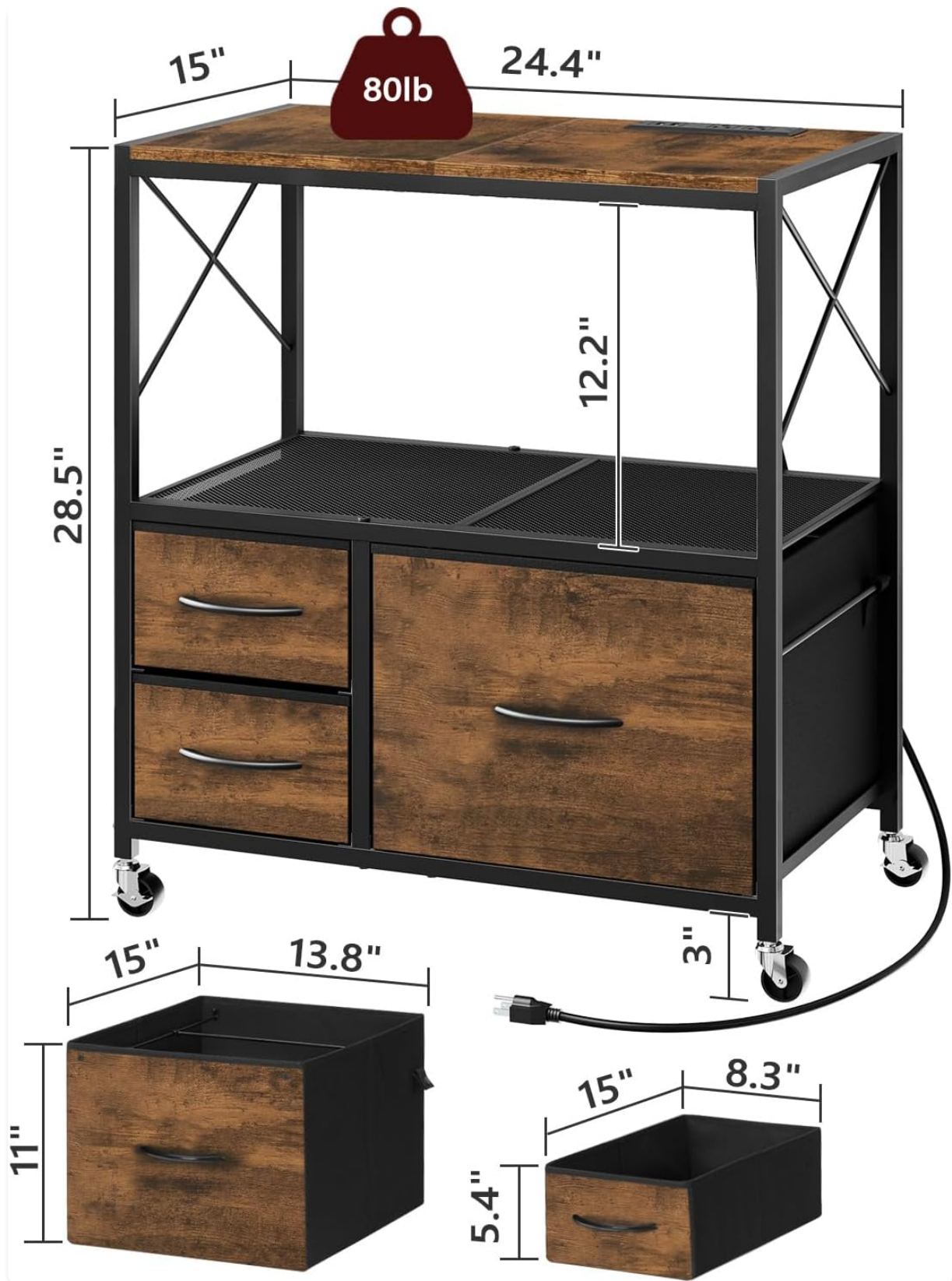

This image illustrates the key dimensions of the file cabinet, including overall size and individual drawer measurements, which are crucial for planning your space.

## 5. SETUP AND ASSEMBLY

The MAHANCRIIS File Cabinet is designed for straightforward assembly. All necessary parts are numbered, and an accessory kit with tools is included. Please follow the detailed illustrated instructions provided in the package for a smooth setup process.

1. **Unpack and Identify Parts:** Carefully unbox all components and lay them out. Compare them with the parts list in the included manual to ensure nothing is missing or damaged.

2. **Assemble the Frame:** Follow the step-by-step diagrams to connect the metal frame pieces using the provided screws and tools. Ensure all connections are secure.
3. **Install Shelves:** Attach the engineered wood top and the metal mesh middle shelf to the frame.
4. **Attach Wheels:** Secure the four universal wheels to the base of the cabinet. Ensure the two lockable wheels are positioned as indicated in the instructions for easy access.
5. **Insert Drawers:** Place the non-woven fabric drawers into their designated compartments. The large drawer includes adjustable hanging rods for A4/Letter size files.
6. **Power Strip:** The power strip is typically pre-installed. Ensure its cord is routed safely and is accessible for plugging into a wall outlet.

## Lockable Universal Wheels

Smooth 360° movement for increased flexibility in the office.



This image highlights the lockable universal wheels, demonstrating how to engage and disengage the lock for stationary use or mobility.

## 6. OPERATING INSTRUCTIONS

### 6.1 Using the Storage Drawers

- The cabinet features three non-woven fabric drawers. The large bottom drawer is equipped with adjustable hanging rods to accommodate both A4 and letter-sized hanging files.

- To adjust the hanging rods, simply reposition them within the drawer frame to fit your desired file size.
- The smaller drawers are suitable for office supplies, documents, or personal items.

## Adjustable Hanging Rods

Suitable for hanging A4 and letter-sized documents and helpful for efficient document management.



This image demonstrates the adjustable hanging rods within the large fabric drawer, allowing for organized storage of A4 or letter-sized documents.

### 6.2 Utilizing the Charging Station

- The integrated charging station includes two standard AC outlets and two USB ports.
- Plug the cabinet's main power cord into a wall outlet.
- Connect your devices such as printers, scanners, laptops, or smartphones to the available outlets or USB ports for convenient power access.

# Convenient Charging Station

2 outlets and 2 USB ports for powering various devices like printers and computers.

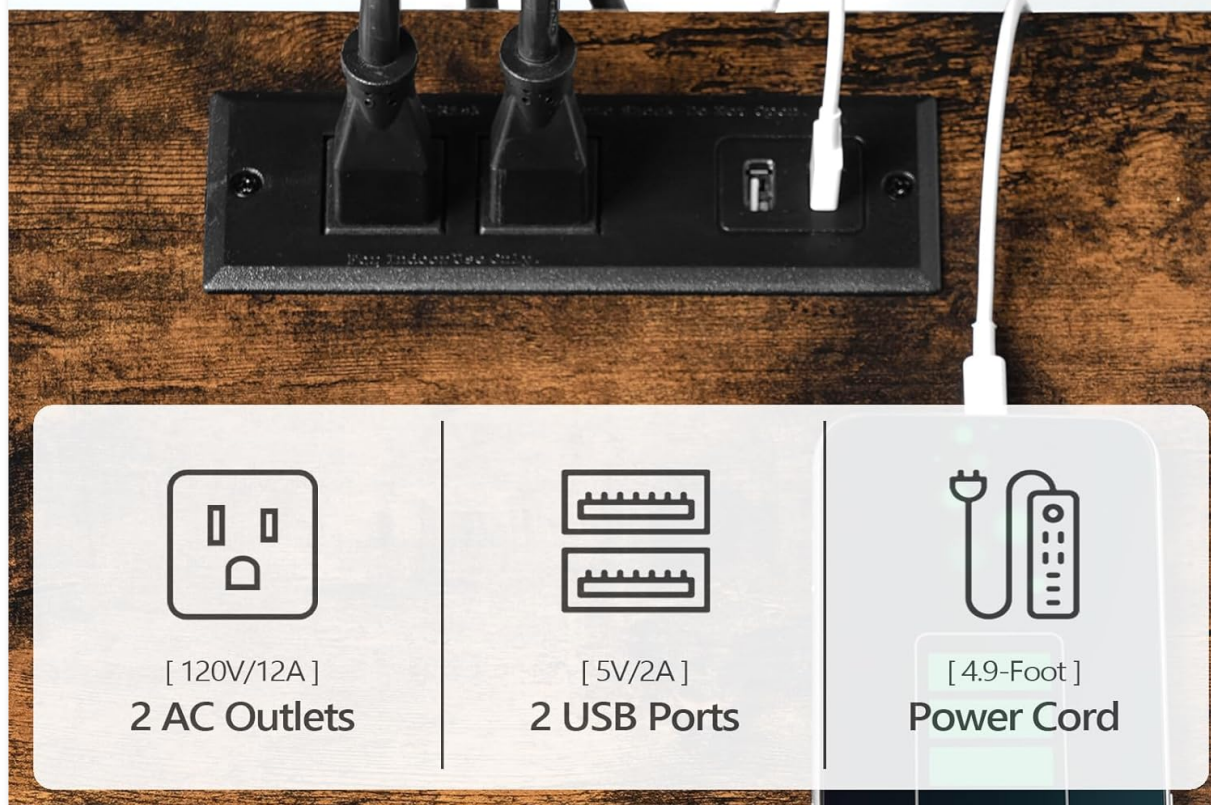

A detailed view of the charging station, featuring two AC outlets and two USB ports, providing easy access to power for multiple electronic devices.

## 6.3 Moving the Cabinet

- The cabinet is equipped with four universal wheels for easy mobility.
- Two of the wheels are lockable. To secure the cabinet in place, press down on the lever of the lockable wheels until they click into the locked position.
- To move the cabinet, lift the levers on the lockable wheels to unlock them, allowing for smooth 360-degree movement.

## 6.4 Official Product Video

Your browser does not support the video tag.

This official product video from MAHANCRI provides a visual overview of the file cabinet's features, including its storage capabilities, charging station, and mobility.

## 7. MAINTENANCE

- **Cleaning:** Wipe the engineered wood and metal surfaces with a soft, damp cloth. Avoid using harsh chemicals or abrasive cleaners, which can damage the finish.

- **Fabric Drawers:** The non-woven fabric drawers should not be washed. For minor spills or dust, gently spot clean with a damp cloth and mild soap, then air dry completely.
- **Regular Checks:** Periodically check all screws and connections to ensure they remain tight and secure. Retighten if necessary.
- **Power Cord:** Inspect the power cord and plug regularly for any signs of wear or damage. Discontinue use and replace if damage is found.

## 8. TROUBLESHOOTING

---

- **Cabinet is Wobbly:** Ensure all assembly screws are fully tightened. Check that the cabinet is on a level surface. If wheels are locked, ensure they are fully engaged.
- **Drawers are Sticking/Difficult to Open:** Ensure drawers are not overloaded. Check for any obstructions within the drawer compartments. The fabric drawers slide on shelves, so ensure they are properly aligned.
- **Charging Station Not Working:** Verify that the cabinet's main power cord is securely plugged into a functional wall outlet. Check if the wall outlet itself is receiving power. Test with a different device.
- **Wheels Not Rolling Smoothly:** Check for debris caught in the wheels. Ensure the wheel locks are fully disengaged.

## 9. WARRANTY INFORMATION

---

MAHANCRIS products are manufactured with quality and durability in mind. This product is covered by a manufacturer's warranty against defects in materials and workmanship. Please refer to the warranty card included in your package or contact MAHANCRIS customer support for specific warranty terms and conditions.

## 10. CUSTOMER SUPPORT

---

Should you have any questions, require assistance with assembly, or encounter any issues with your MAHANCRIS File Cabinet, please do not hesitate to contact our customer support team. Contact information can typically be found on the MAHANCRIS official website or on the packaging materials.