

BANRIA 263BAEA

BANRIA 4-Digit Digital Alarm Clock Soldering Practice Kit User Manual

Model: 263BAEA

INTRODUCTION

This manual provides detailed instructions for assembling and operating your BANRIA 4-Digit Digital Alarm Clock Soldering Practice Kit. Designed for students, beginners, and soldering enthusiasts, this kit offers an engaging way to enhance practical skills while building a functional digital clock. Please read this manual thoroughly before beginning assembly or operation.

SAFETY INFORMATION

- Always work in a well-ventilated area when soldering.
- Use appropriate personal protective equipment, including safety glasses.
- Ensure your soldering iron is properly grounded and handled with care to prevent burns.
- Keep all components and tools out of reach of children.
- Do not apply power to the circuit until all components are correctly soldered and inspected.
- Use only the specified DC 5V power input.

PACKAGE CONTENTS

Verify that all components listed below are present in your kit:

- Main Circuit Board (PCB)
- 4-Digit RGB Digital Tube Display
- Micro USB Power Cable
- Electronic Components (resistors, capacitors, ICs, buttons, buzzer, sensors, etc.)
- Acrylic Casing Components
- Detailed Paper Manual with Installation Tutorials and Schematics

SETUP AND ASSEMBLY

The BANRIA Digital Alarm Clock kit is designed for user-friendly assembly, featuring pre-soldered SMD LEDs and a clearly marked circuit board. Follow the detailed instructions and schematics provided in the included paper manual for a step-by-step assembly process. The estimated assembly time is approximately 40 minutes.

Component Identification

Familiarize yourself with the main components of the circuit board before soldering.

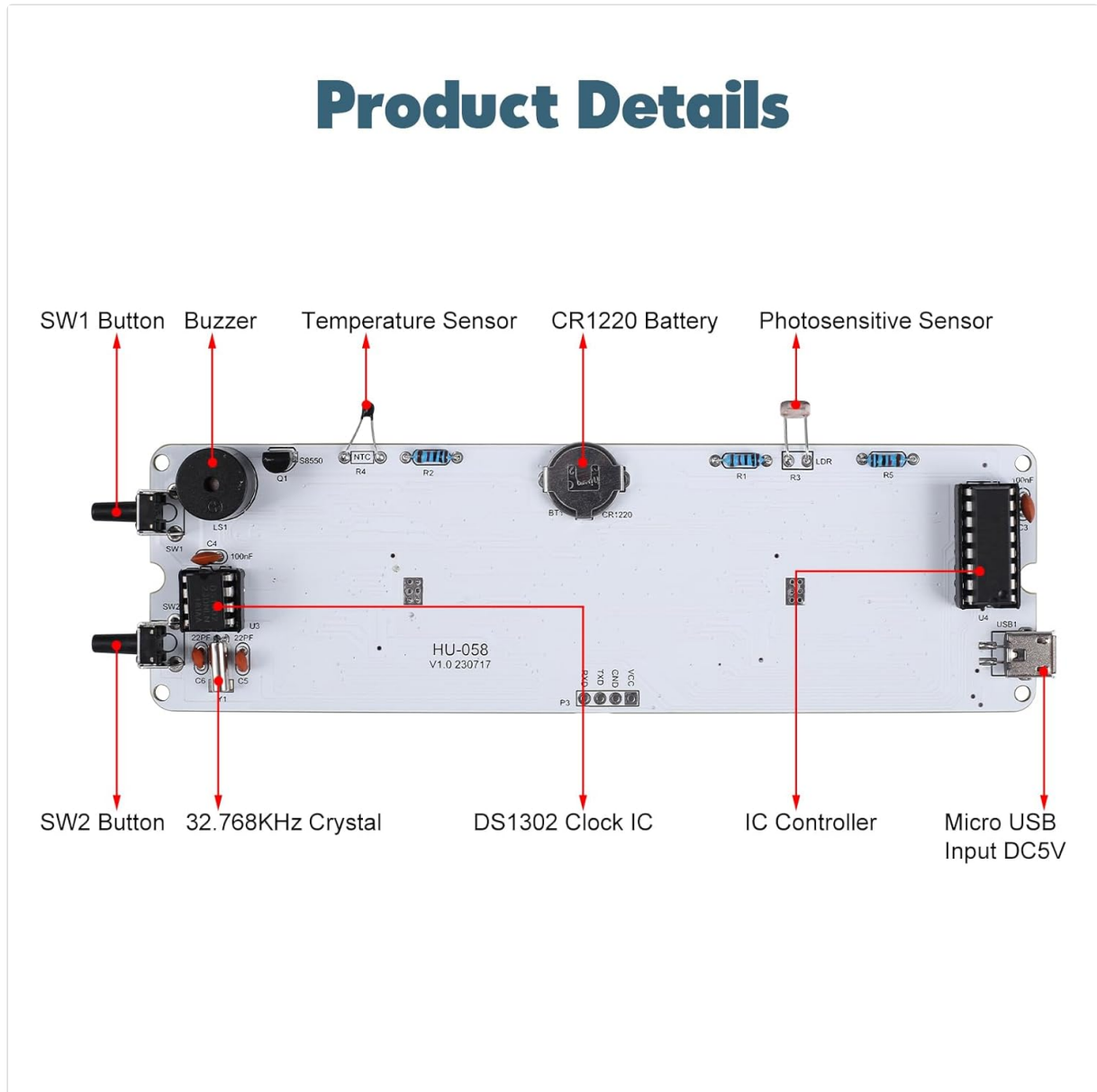

Figure 1: Circuit board with labeled components including buttons, sensors, battery, and Micro USB input.

Soldering Process

Perform through-hole soldering for the various components onto the PCB. Ensure correct polarity for diodes and electrolytic capacitors. Refer to the schematic diagram for connection details.

Schematic Diagram

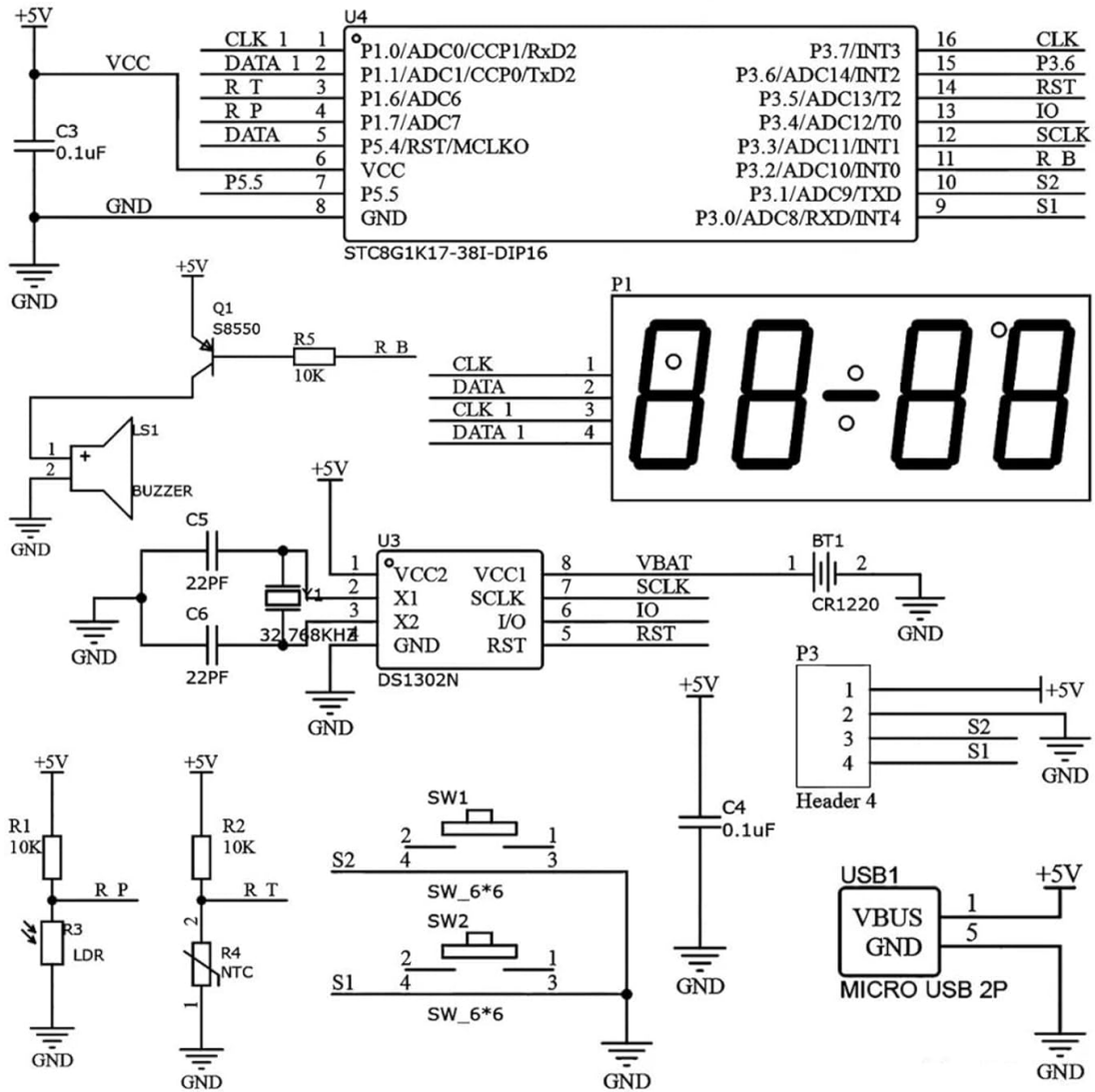

Figure 2: Schematic diagram illustrating the circuit connections for assembly.

After soldering, carefully inspect all joints for cold solders, bridges, or incorrect component placement. Once assembly is complete, connect the Micro USB cable to a DC 5V power source to power on the clock.

4 Display Modes of RGB Digital Tube

Give You Unique Visual Experience Through 27 Colors

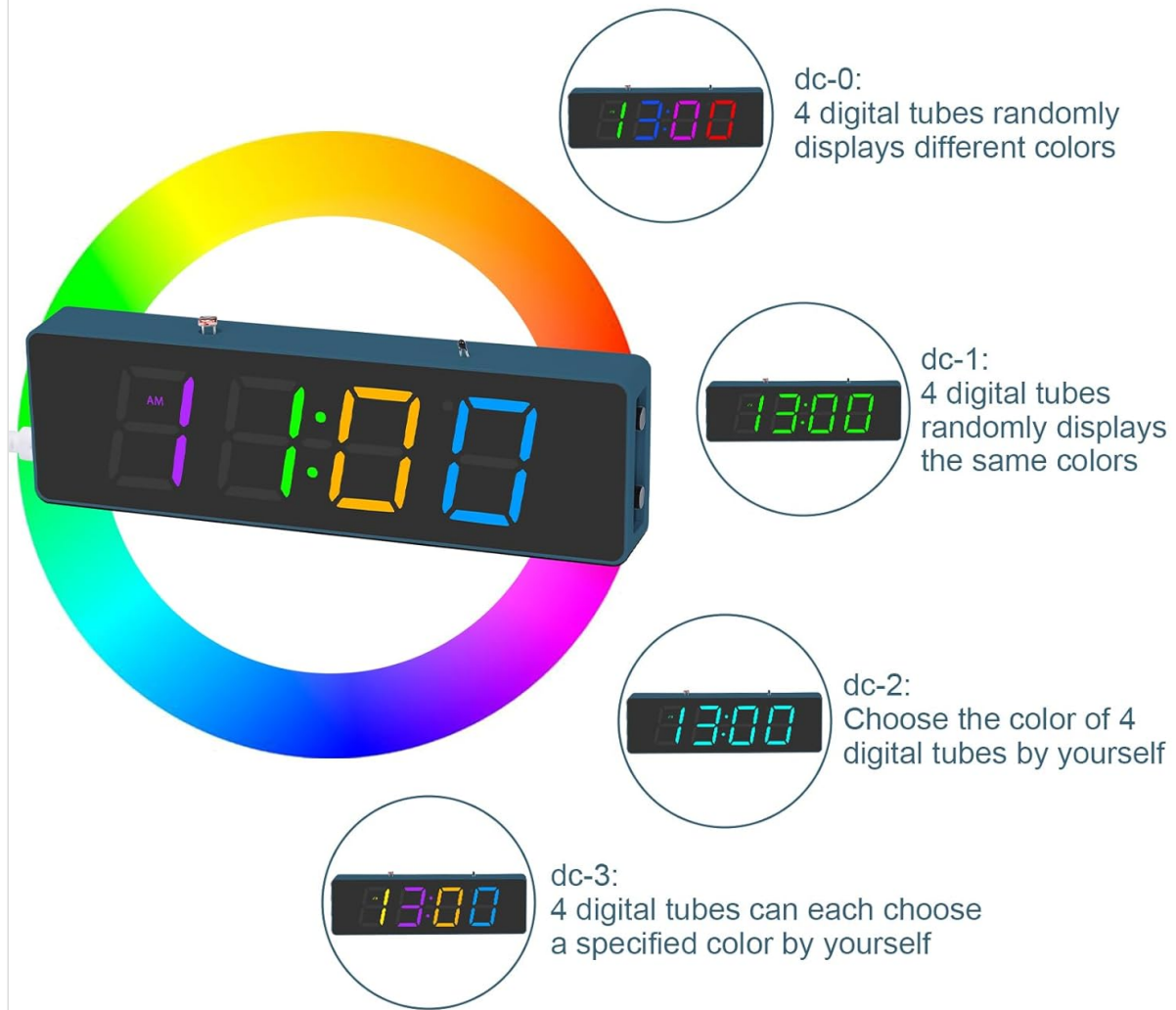

Figure 3: Illustrative image of the DIY soldering process and the assembled clock.

OPERATING INSTRUCTIONS

Your BANRIA Digital Alarm Clock offers various functions and customization options. Use the control buttons (SW1, SW2) on the device to navigate menus and adjust settings.

Basic Display Functions

The clock can display the current time, date, day of the week, and ambient temperature. Cycle through these displays using the designated button (refer to your paper manual for specific button functions).

Time and Date Settings

To set the time and date, enter the settings mode by pressing and holding the appropriate button. Adjust hours, minutes, year, month, and day using the navigation buttons. The clock supports both 12-hour and 24-hour display formats.

4 Characteristic functions

Meet Your Needs



12/24H
Time Format



Large Screen
Display



Power
Memory



4 Levels of
Brightness



Figure 4: Key features including time format, display size, power memory, and brightness levels.

Alarm Settings

The clock allows you to set up to three independent alarms. Each alarm can be configured with specific times and one of four available alarm sounds. You can also set alarms for everyday, Monday to Friday, or Monday to Saturday.



Figure 5: Configuration options for the three independent alarms.

RGB Display Modes and Brightness

The RGB digital tube offers 4 distinct display modes and 27 color options to personalize your clock's appearance. The clock also features light-controlled automatic brightness adjustment and 3-speed manual brightness settings to ensure optimal visibility in any lighting condition.

- **dc-0:** All four digital tubes randomly display different colors.
- **dc-1:** All four digital tubes randomly display the same color.
- **dc-2:** You can choose a single color for all four digital tubes.
- **dc-3:** Each of the four digital tubes can be set to a specified color individually.



Figure 6: Visual representation of the 4 RGB display modes.

MAINTENANCE

To ensure the longevity and proper functioning of your digital alarm clock, follow these maintenance guidelines:

- Keep the device clean and dry. Use a soft, dry cloth to wipe the display and casing.
- Avoid exposure to extreme temperatures, direct sunlight, or high humidity.
- Do not use abrasive cleaners or solvents, as these can damage the casing and electronic components.
- Ensure the power connection is secure and free from damage.

TROUBLESHOOTING

If you encounter issues with your BANRIA Digital Alarm Clock, refer to the following common problems and solutions:

- **Clock does not power on:**
Ensure the Micro USB cable is securely connected to both the clock and a functional DC 5V power source. Check the power adapter and cable for any damage.
- **Time reverts to 3:00 AM or incorrect time:**

This issue may indicate a problem with the clock's internal timekeeping chip or its connections. Carefully re-inspect all soldered connections related to the DS1302 Clock IC and the 32.768KHz Crystal. If the problem persists after verifying connections and power, contact customer support.

- **Difficulty setting time or features:**

The clock has numerous settings and requires specific button sequences for configuration. Refer to the detailed paper manual for precise instructions on navigating menus and adjusting settings. Patience is often required for initial setup.

- **Inaccurate temperature reading:**

The temperature sensor provides an approximate reading. While it can be adjusted, significant fluctuations in ambient temperature may affect its accuracy. Ensure the sensor is not obstructed or exposed to direct heat sources.

- **Display is dim or too bright:**

Adjust the manual brightness settings using the control buttons. If automatic brightness is enabled, ensure the photosensitive sensor is not covered or in an unusually dark/bright environment.

SPECIFICATIONS

Brand	BANRIA
Model Number	263BAEA
Display Type	LED (RGB)
Power Input	Micro USB DC 5V
Product Dimensions (LxWxH)	16.5 x 2.1 x 1.8 cm
Item Weight	132 g
Functions	Time, Date, Week, Temperature Display, 3 Alarms, RGB Color Modes, Brightness Control (Auto/Manual), 12H/24H Format
Included Components	DIY Clock Components, Circuit Board, Micro USB Cable, Paper Manual

WARRANTY AND SUPPORT

For any questions, technical assistance, or support regarding your BANRIA 4-Digit Digital Alarm Clock Soldering Practice Kit, please refer to the contact information provided in your product packaging or reach out to BANRIA customer service. Please retain your purchase receipt for any warranty claims.