



[Manuals.plus](#) /

› [WOODBIDGE](#) /

› WOODBRIDGE Smart Toilet B0931S Voice Control User Manual

WOODBIDGE B0931S

WOODBIDGE Smart Toilet B0931S Voice Control User Manual

Model: B0931S

[Introduction](#)

[Setup](#)

[Operating Instructions](#)

[Maintenance](#)

[Troubleshooting](#)

[Specifications](#)

[Warranty & Support](#)

1. INTRODUCTION

This manual provides detailed instructions for the installation, operation, and maintenance of your WOODBRIDGE Smart Toilet with Voice Control, Model B0931S. Please read this manual thoroughly before installation and use to ensure proper function and safety.

Your browser does not support the video tag.

Video: Introduction to the WOODBRIDGE Smart Toilet B0931S. This video provides an overview of the toilet's features and voice control capabilities.

2. SETUP AND INSTALLATION

2.1 Pre-Installation Considerations

- Ensure the installation area meets ADA compliance for comfort height (17-3/8" floor-to-seat height).
- Verify water supply and electrical outlets are accessible and meet local codes.
- This is a floor-mounted unit. Professional installation is recommended to ensure proper setup and warranty validity.

2.2 Foam Agent Refill (Initial Setup & Maintenance)

The Foam Shield feature requires a special foaming agent. Follow these steps to refill the foam liquid:

1. Locate the foam agent liquid filling port on the side of the toilet.
2. Open the port and remove the cap.

3. Carefully pour the WOODBRIDGE Special Foaming Agent into the compartment. Fill approximately half a bottle.
4. Replace the cap and close the filling port securely.
5. To activate the foam function for the first time or after refilling, press and hold the "FOAM CLEANER" button on the remote control for 1-2 minutes until foam is dispensed automatically.
6. To enable automatic foam shield function when seated, hold the "STOP" button, then press the "FOAM CLEANER" button. A 'beep' sound confirms activation.

Your browser does not support the video tag.

Video: Guide to Foam Shield Operations. This video demonstrates how to refill the foam agent and activate the foam shield function.

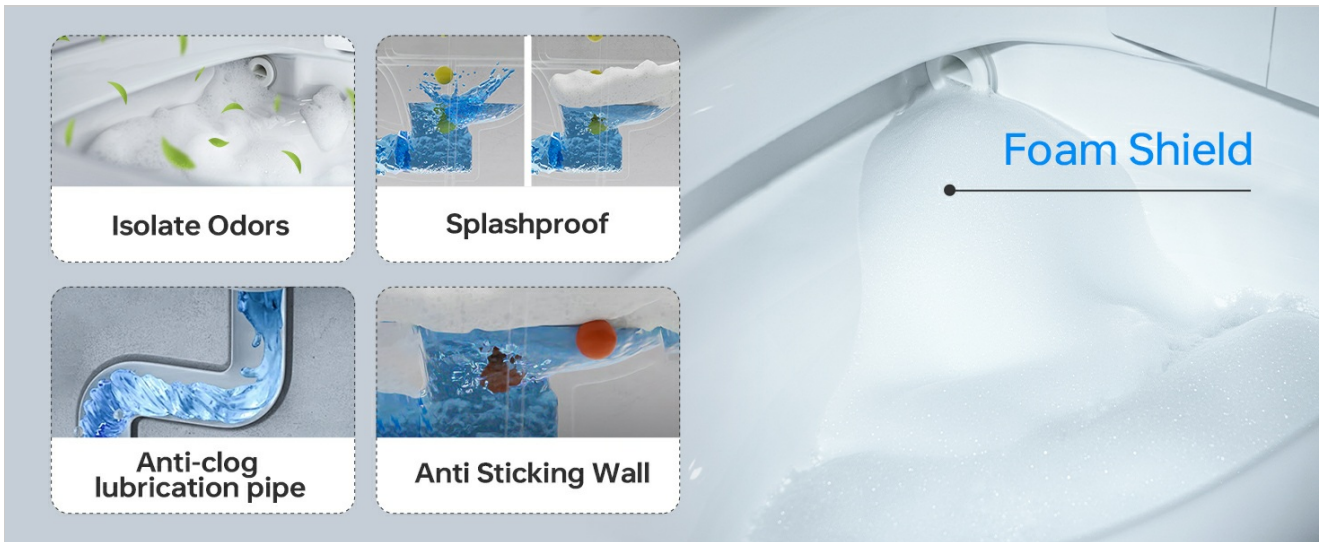

Image: The Foam Shield feature in action, illustrating its benefits including odor isolation, splash prevention, and anti-sticking properties.

3. OPERATING INSTRUCTIONS

3.1 Voice Control

The WOODBRIDGE Smart Toilet B0931S features hands-free voice control. Simply say the wake word followed by a command:

- **Wake Word:** "Hey Smart" or "Hi Smart"
- **Commands:**
 - "Open the cover" / "Open the seat"
 - "Close the cover" / "Close the seat"
 - "Full flush" / "Half flush"
 - "Turn on drying"
 - "Front wash" / "Rear wash" / "Moving wash"

VOICE CONTROL

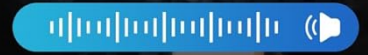

Open the cover/seat



Full flush

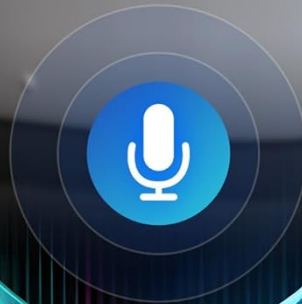

Voice Human-Computer Interaction Use your voice to control it,
Completely free your hands and make the operation easier.

Image: Visual representation of the voice control feature, demonstrating commands for opening the lid/seat and initiating a full flush.

3.2 Automatic Functions

- **Auto Open & Close:** The lid automatically opens as you approach and closes after you leave.
- **Auto Flush:** The toilet flushes automatically after you leave.
- **Foot Sensor:** A foot sensor allows for touch-free opening/closing of the seat and lid, and flushing.
- **Foam Shield:** Automatically dispenses foam into the bowl when seated (if activated in setup).

AUTO OPEN & CLOSE



Image: The automatic open and close feature, showing the lid and seat responding to user approach.

3.3 Bidet and Drying Functions

- **Wash Modes:** Choose from front, rear, or oscillating wash for a customized cleaning experience.
- **Adjustable Settings:** Water flow, spray position, and water temperature are adjustable via the remote control.
- **Heated Seat:** The seat temperature can be adjusted to 6 levels for comfort.
- **Moving Dryer:** Features a back-and-forth drying motion with low, medium, and high air speed settings. Air temperature is also adjustable.

MULTIPLE CLEANING MODES

Multi-directional, multi-mode cleaning, feel different washing experience



Rear wash

Farewell to the troubles of hemorrhoids



Front wash

Clean during menstruation/pregnancy



Movement wash

Moving back and forth, large area flushing

Image: Illustration of the multiple cleaning modes available, including rear, front, and moving wash options.

MOVEMENT DRYING

Mobile drying mode allows dry air nozzle to move up and down to ensure complete dryness.

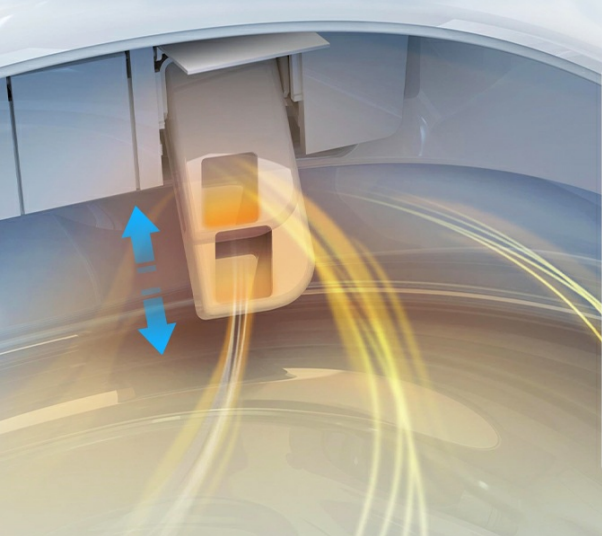

Temp

Room Temperature 86°F 95°F 104°F 113°F 122°F

Speed

low medium high

Image: Details of the Moving Dryer function, highlighting adjustable temperature and air speed settings for efficient drying.

3.4 Flushing System

- **Dual Flush:** Select between a 1.6 GPF (Gallons Per Flush) full flush or a 1.1 GPF half flush for water conservation.
- **1000g MaP Flush Score:** Ensures powerful and effective waste removal.
- **Power-Off Flush:** In case of a power outage, use the side button for manual flushing.



Tested & Certified by **intertek**

WOODBIDGE Toilet MaP Score:

Best MaP Flush Performance Score at **1000 Grams**



MaP Score
Best Maximum performance flush score of **1000 grams**



1000 gram MaP

Map Scoring Guide

(grams of waste removed in a single flush)

1,000g-600g		Highly Recommended
600g-350g		Recommended
350g-250g		Acceptable
250g-0g		Not Recommended

POWER OUTAGE FLUSHING

Reliable Flushing During Power Outages Battery Backup for Emergency Use

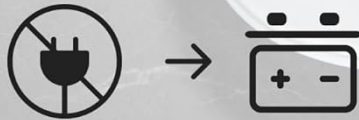

Use battery power when power is lost



Never worry about power outages again with our toilet's battery backup

Built-in Battery Box
(batteries not included)

Image: The power outage flushing feature, showing how to manually flush using the side button with battery backup.

3.5 Additional Features

- **Auto Deodorizing:** A catalyst-free system breaks down odor molecules for continuous freshness.
- **Night Light:** An integrated night light provides subtle illumination for nighttime use.
- **Remote Control:** A wireless remote control provides full access to all functions and settings.
- **Digital Display:** An LED display shows current settings like water and seat temperature, and indicates ECO mode.



Image: The wireless remote control, displaying icons for various functions such as wash modes, drying, and temperature adjustments.

4. MAINTENANCE

- **Nozzle Cleaning:** The bidet nozzle is self-cleaning and removable for thorough manual cleaning if needed.
- **Foam Agent:** Regularly check the foam agent level and refill as described in Section 2.2. Each bottle typically lasts 2-4 months depending on usage.
- **General Cleaning:** Use mild, non-abrasive cleaners for the toilet's exterior. Avoid harsh chemicals that may damage surfaces.

5. TROUBLESHOOTING

- **No Power/Functions Unresponsive:**
 - Check if the toilet is properly plugged into a working electrical outlet.
 - Ensure the circuit breaker has not tripped.

- If there's a power outage, use the manual flush button on the side.

- **Foam Shield Not Activating:**

- Check the foam agent level and refill if necessary (refer to Section 2.2).
- Ensure the automatic foam shield function is enabled via the remote control (refer to Section 2.2).

- **Bidet Spray Issues:**

- Check water pressure settings on the remote.
- Ensure the nozzle is not obstructed; perform a self-cleaning cycle or manually clean if needed.

- **Voice Control Not Responding:**

- Ensure you are using the correct wake word ("Hey Smart" or "Hi Smart").
- Speak clearly and at a normal volume.
- Check for any obstructions near the microphone.

For issues not covered here, please contact WOODBRIDGE Customer Support.

6. PRODUCT SPECIFICATIONS

Feature	Detail
Model Number	B0931S
Color	B0931S Voice Control
Product Dimensions	27.63"D x 16.53"W x 19.68"H
Material	Porcelain or Ceramic (Seat: Plastic)
Item Weight	118.7 pounds (53.98 Kilograms)
Installation Type	Floor Mounted
Flush Performance	1000g MaP Flush Score
Flush System	Dual Flush (1.6 GPF Full / 1.1 GPF Half)
Seat Height (ADA)	17-3/8" (from floor to seat)
Included Components	Toilet
Batteries Required	No (for main operation, battery backup for power-off flush)

WOODBIDGE®

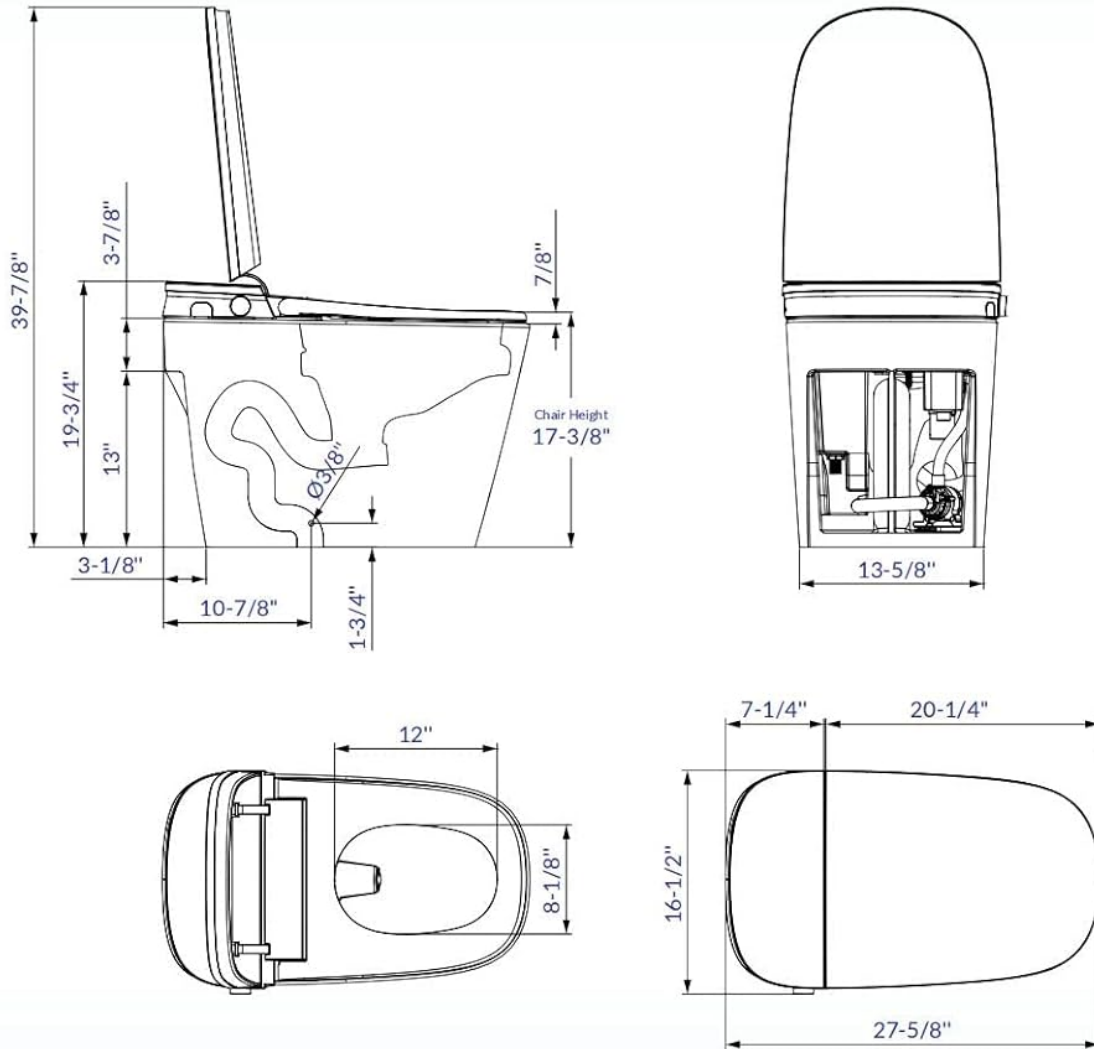

IMPORTANT INFORMATION

- Measurements are +3/8" and subject to change without notice
- Specifications & Configurations are subject to change without notice
- Pls measure toilet on-site before installation
- Please note that installer(s) must certify or warranty will be voided.
- Measurements herein supersede all others published prior to publication date shown below

www.woodbridgebath.com

Image: Detailed dimensions and technical specifications of the WOODBRIDGE Smart Toilet B0931S.

17.4" ADA SEAT HEIGHT



Image: Visual comparison highlighting the ADA compliant comfort height of the B0931S model.

7. WARRANTY & SUPPORT

WOODBIDGE is committed to providing top-quality products and exceptional service. Your WOODBRIDGE Smart Toilet B0931S comes with a manufacturer's warranty. For specific warranty details, please refer to the documentation included with your product or contact customer support.

Customer Support: Our U.S.-based support team is available to assist with product advice, installation help, after-sales service, and free warranty replacement parts.

- **Email:** help@woodbridgebath.com
- **Phone:** (Refer to product packaging or official website for phone number)

