

Manuals+

[Q & A](#) | [Deep Search](#) | [Upload](#)

Manuals.plus /

› [EARUMZDQ](#) /

› EARUMZDQ PC311 Smart Two-Way Bilateral WiFi Energy Meter Instruction Manual

EARUMZDQ SCT-T10

EARUMZDQ PC311 Smart Two-Way Bilateral WiFi Energy Meter Instruction Manual

Brand: EARUMZDQ | Model: SCT-T10

PRODUCT OVERVIEW

The EARUMZDQ PC311 Smart Two-Way Bilateral WiFi Energy Meter is designed to monitor electricity consumption and generation in both AC110V and 220V systems. It provides real-time data on voltage, current, active power, and power factor, accessible via the Tuya or Smart Life mobile applications. This device is ideal for tracking energy usage from the city grid and power generated by solar PV systems, offering comprehensive insights into your home's energy flow.



Image: The EARUMZDQ PC311 Smart Energy Meter module connected to two 80A Current Transformer (CT) clamps.

Key Features:

- **Two-Way Energy Monitoring:** Capable of monitoring both energy consumed from the city grid and energy generated by solar PV systems.
- **Remote Monitoring:** Connects to 2.4G WiFi for real-time data access and control via Tuya APP or SMART LIFE APP from anywhere.
- **Comprehensive Measurement:** Measures Voltage, Current, Power Factor, and Active Power.
- **High Current Capacity:** Includes two 80A Current Transformer (CT) Clamp Sensors with a 10MM hole diameter, supporting a current measure range of 80A+80A.
- **Smart Home Integration:** Supports Tap-to-Run and automation features with other Tuya-compatible devices.
- **Historical Data Logging:** Provides hour, day, month, and year energy consumption records on the APP, retaining data for over one year.
- **Standard Installation:** Designed for 35MM DIN RAIL mounting.

WHAT'S IN THE BOX

- 1 x PC311 Smart Energy Meter Module
- 2 x 80A Current Transformer (CT) Clamp Sensors (10MM Diameter)

SETUP AND INSTALLATION

1. Physical Installation

The PC311 module is designed for 35MM DIN RAIL installation. Ensure the device is installed in a location with stable 2.4G WiFi coverage and within the specified ambient temperature and humidity ranges.

Technical Specifications

Wireless Connectivity	
Wi-Fi	802.11 B/G/N20/N40@2.4GHz
BLE	Bluetooth 4.2 Low Energy
RF Characteristics	Operating frequency: 2.4GHz Internal antenna
Physical Specifications	
Operating Voltage	90~250 Vac 50/60 Hz
Calibrated Metering Accuracy	$\leq 100W$ (Within $\pm 2W$) $>100W$ (Within $\pm 2\%$)
Reporting Cycle	Every 15 seconds
Operating environment	Temperature: $-20\text{ }^{\circ}\text{C} \sim +55\text{ }^{\circ}\text{C}$ Humidity: $\leq 90\%$ non-condensing

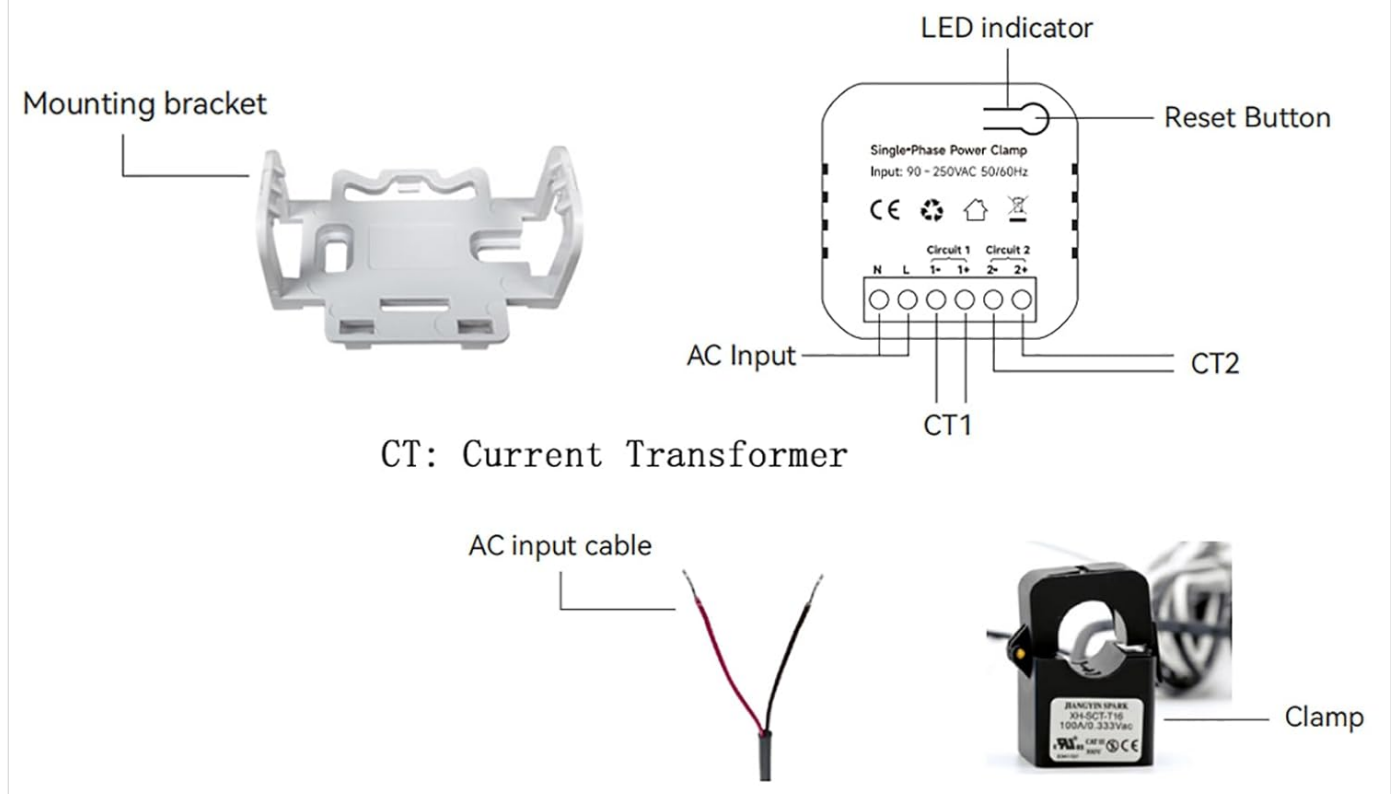

Image: Diagram showing the PC311 module with AC input, CT clamp connections, LED indicator, and reset button, along with mounting bracket details.

2. Wiring Diagram

Proper wiring is crucial for accurate measurement. Refer to the diagrams below for connecting the CT clamps based on your monitoring needs (consumption from grid, generation from solar, or load monitoring).

Clip Clamp1 onto Grid: Measure "From Grid" or "To Grid" energy

If the measured current direction is $K \rightarrow L$ or $P1 \rightarrow P2$, the energy reading is accumulated as "From Grid" Energy
If the measured current direction is $L \rightarrow K$ or $P2 \rightarrow P1$, the energy reading is accumulated as "To Grid" Energy

Clip Clamp2 onto Inverter: Measure how much energy generated by inverter, the direction of the clamp needs to point to inverter

Clip Clamp3 onto Load: Measure how much energy generated by Load, the direction of the clamp needs to point to Load

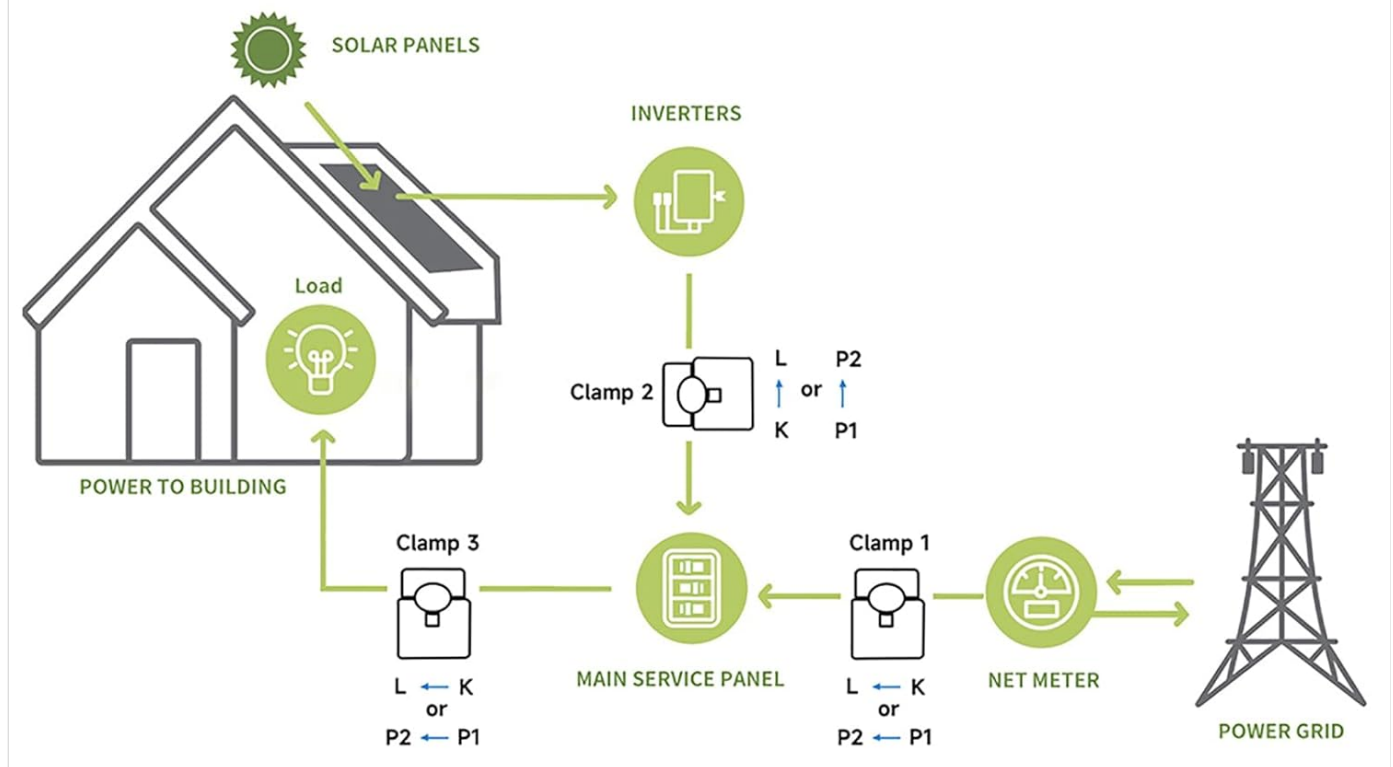
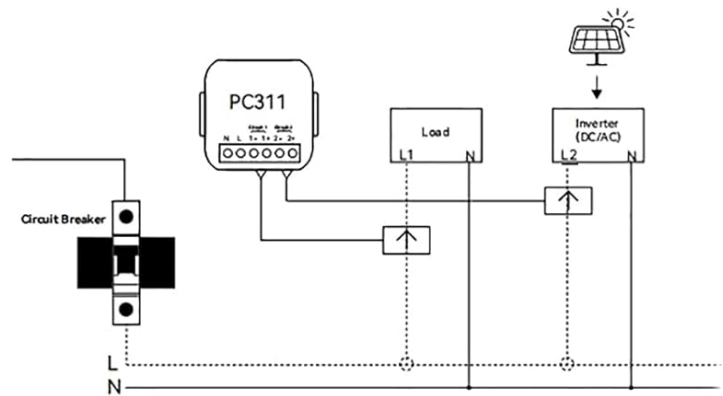

Image: Comprehensive wiring diagram illustrating how to connect CT clamps for measuring energy from the grid, from an inverter (solar generation), and from a specific load.

Important: The direction of the CT clamp matters for accurate readings. For measuring energy generation, the arrow on the clamp should face the inverter. For measuring consumption from the grid, install the CT on the leads coming from your mains.

To Measure Energy Generation

The arrow on the clamp should face to inverter like CT2 in the wiring diagram. In this case, the direction of the current is opposite to that of the CT. The power will be negative, and the energy generation will be accumulated.



Wiring diagram

To Measure 'From Grid' or 'To Grid'

To monitor how much energy is pulling from and sending back from the grid, install the CT on the leads coming from your mains like the CT1 below.

For CT1:

If the measured current direction is $K \rightarrow L$, the energy consumption is accumulated as 'From Grid' energy.

If the measured current direction is $L \rightarrow K$, the energy generation is accumulated as 'To Grid' energy

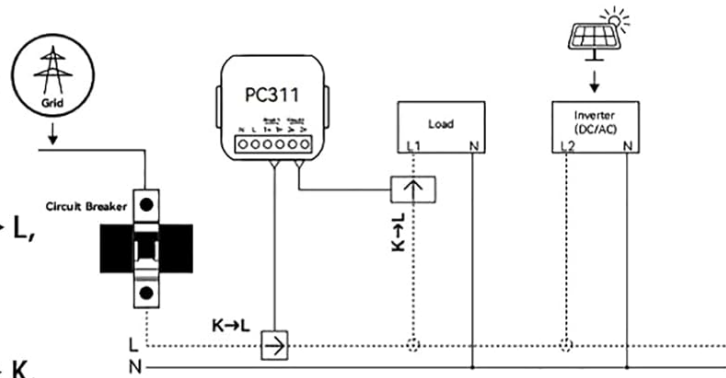

Wiring diagram

Image: Two separate wiring diagrams. The top diagram shows CT2 connected to monitor energy generation from an inverter. The bottom diagram shows CT1 connected to monitor energy consumption from the grid, with arrows indicating current direction for 'From Grid' and 'To Grid' energy accumulation.

3. App Connection (Tuya/Smart Life)

The device connects to your home's 2.4G WiFi network. 5G WiFi is not supported. Follow these steps to pair the device with the Tuya or Smart Life app:

1. Download and install the Tuya Smart or Smart Life app from your mobile app store.
2. Register or log in to your account.
3. Power on the PC311 module. The LED indicator should blink, indicating pairing mode.
4. Open the app, tap "Add Device" or the "+" icon.
5. The app should automatically discover the device (PC311_TY). Tap "Add".
6. Enter your 2.4G WiFi network name and password when prompted.
7. Wait for the device to connect. Once connected, you can rename it and start monitoring.

Your browser does not support the video tag.

Video: A demonstration of the PC311 App Operation, showing the process of adding the device to the Tuya/Smart Life app and navigating through its features.

OPERATING INSTRUCTIONS

Monitoring Energy Data

Once connected, the Tuya or Smart Life app provides a comprehensive interface for monitoring your energy data. The data refreshes every 15 seconds.

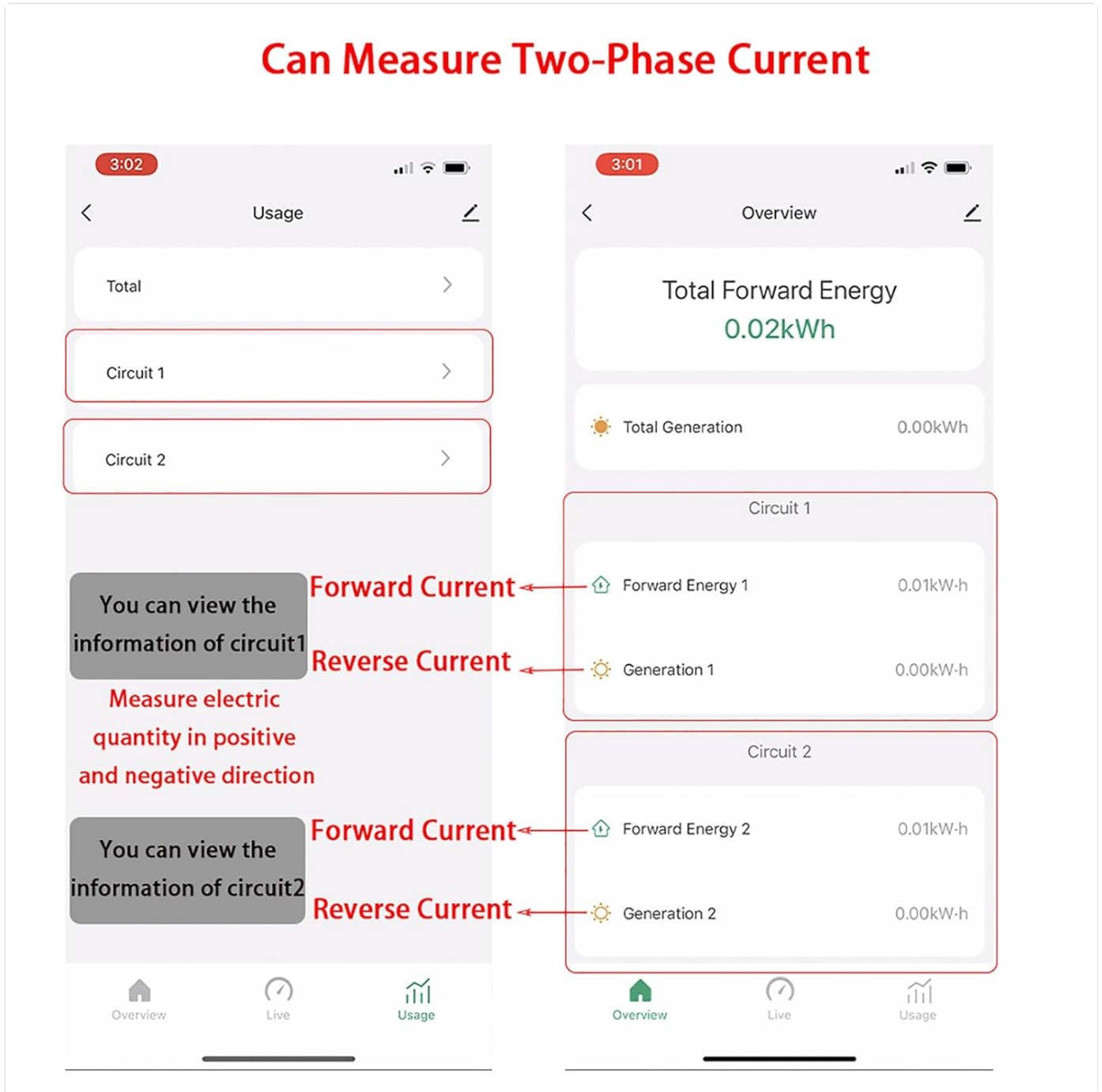

Image: Screenshots of the mobile application interface, demonstrating how to view total forward energy, total generation, and detailed information for Circuit 1 and Circuit 2, including forward and reverse current measurements.

- **Total Forward Energy:** Displays the total energy consumed.
- **Total Generation:** Displays the total energy generated (e.g., from solar panels).
- **Circuit 1 & Circuit 2:** Provides detailed readings for each connected CT clamp, including current, active power, and

power factor.

- **Historical Data:** Navigate through the app to view energy consumption records by hour, day, month, or year. The app stores data for over one year.



Image: A screenshot of the app displaying a daily energy consumption graph, showing total forward energy and total generation over time, with example appliances in the background.

Automation and Scene Creation

Leverage the "Tap-to-Run" and automation features within the Tuya/Smart Life app to integrate the energy meter with other smart devices. For example, you can set up automations based on energy consumption thresholds.

MAINTENANCE

The EARUMZDQ PC311 energy meter requires minimal maintenance. Ensure the device is kept within its specified operating environment conditions:

- **Temperature:** -10°C to 55°C

- **Humidity:** ≤90% non-condensing

Regularly check the physical connections of the CT clamps and power input to ensure they are secure. Keep the device clean and free from dust and moisture.

TROUBLESHOOTING

Problem	Possible Cause	Solution
Device not connecting to WiFi.	Incorrect WiFi password; 5G WiFi network; device too far from router; router issues.	<p>Verify WiFi password.</p> <p>Ensure you are connecting to a 2.4G WiFi network (5G is not supported).</p> <p>Move the device closer to the WiFi router.</p> <p>Restart your WiFi router.</p>
Inaccurate energy readings.	Incorrect CT clamp direction; loose CT clamp connection; faulty CT clamp.	<p>Check the direction of the CT clamp (arrow should point towards the load/inverter as per wiring diagram).</p> <p>Ensure CT clamps are securely closed around the wire.</p> <p>Verify wiring connections to the module.</p> <p>If issues persist, contact customer support.</p>
No data displayed in the app.	Device offline; app synchronization issue; power supply issue.	<p>Check if the device's LED indicator is solid (connected).</p> <p>Ensure the device has stable power.</p> <p>Restart the app.</p> <p>If the device is offline, re-pair it with the app.</p>

For further assistance, please refer to the manufacturer's support channels.

SPECIFICATIONS

Feature	Detail
Model Number	SCT-T10
Rated Voltage	AC90-250V, 50/60HZ
Current Measure Range	80A+80A (with 2PCS 80A CT Clamp Sensors)
CT Clamp Hole Diameter	10MM
Wireless Connectivity	2.4G WiFi (IEEE 802.11 b/g/n), Bluetooth 4.2 Low Energy
Compatible Apps	Tuya App, SMART LIFE App
Data Refresh Rate	1 time / 15 seconds
Installation	35MM DIN RAIL
Ambient Temperature Range	-10°C ~ 55°C
Humidity	≤90% non-condensing

Feature	Detail
Product Dimensions	1.81 x 1.81 x 0.71 inches
Weight	6 ounces
Manufacturer	ZHEJIANG EARU ELECTRONICS CO.,LTD
Country of Origin	China

Product Size

Transformer Pliers:

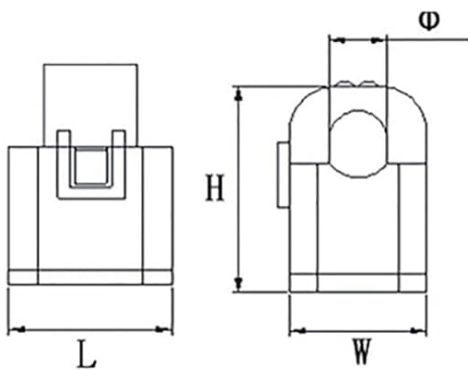

Model	L	W	H	Φ	Weight
80A	26mm	23mm	40mm	10mm	80g



Image: Detailed diagram illustrating the dimensions of the PC311 module and the 80A CT clamp, including length, width, height, and CT hole diameter.

WARRANTY AND SUPPORT

For warranty information and technical support, please contact EARUMZDQ directly through their official website or the contact information provided with your purchase. Keep your purchase receipt as proof of purchase.

Manufacturer: ZHEJIANG EARU ELECTRONICS CO.,LTD

© 2024 EARUMZDQ. All rights reserved.