



[Manuals.plus](#) /

› [BAOSHISHAN](#) /

› BAOSHISHAN DL-100LB Force Gauge + APW Test Stand Extended Version User Manual

BAOSHISHAN DL-100LB

BAOSHISHAN DL-100LB Force Gauge + APW Test Stand Extended Version

User Manual

1. INTRODUCTION

This manual provides comprehensive instructions for the safe and effective use of the BAOSHISHAN DL-100LB Force Gauge and the APW Test Stand Extended Version. This combined system is designed for precise measurement of push and pull forces in various industrial and scientific applications. Please read this manual thoroughly before operation to ensure proper setup, accurate measurements, and prolonged product life.



Figure 1.1: The BAOSHISHAN DL-100LB Force Gauge and APW Test Stand Extended Version. This image displays the complete bundle, including the handheld force gauge with its analog dial and the extended test stand featuring a handwheel for precise movement.

2. PRODUCT COMPONENTS

The BAOSHISHAN DL-100LB Force Gauge and APW Test Stand Extended Version bundle includes the following main components:

- **DL-100LB Force Gauge:** An analog device for measuring push and pull forces up to 100LB.
- **APW Test Stand Extended Version:** A mechanical stand designed to provide stable and precise movement for force measurement applications.
- **Metal Test Accessories:** Various attachments for the force gauge to accommodate different testing requirements.
- **Mounting Hardware:** Screws and clamps for assembly and securing the force gauge.



METAL TEST ACCESSORIES

The parts can be selected according to different measurement requirements.

Figure 2.1: Metal Test Accessories. This image shows the various interchangeable metal tips that can be attached to the force gauge, allowing for different contact points and measurement scenarios.

3. SETUP AND ASSEMBLY

Follow these steps to assemble and set up your force measurement system:

1. Assemble the APW Test Stand:

- Attach the handwheel to the designated shaft on the test stand. Use the provided hex wrench to secure it firmly.
- Install the fixing clamps onto the test stand rails. These clamps will be used to secure the force gauge or the object under test. Ensure they are tightened with the hex wrench.

USE HEX WRENCHES TO INSTALL HANDWHEEL AND FIXING CLAMPS

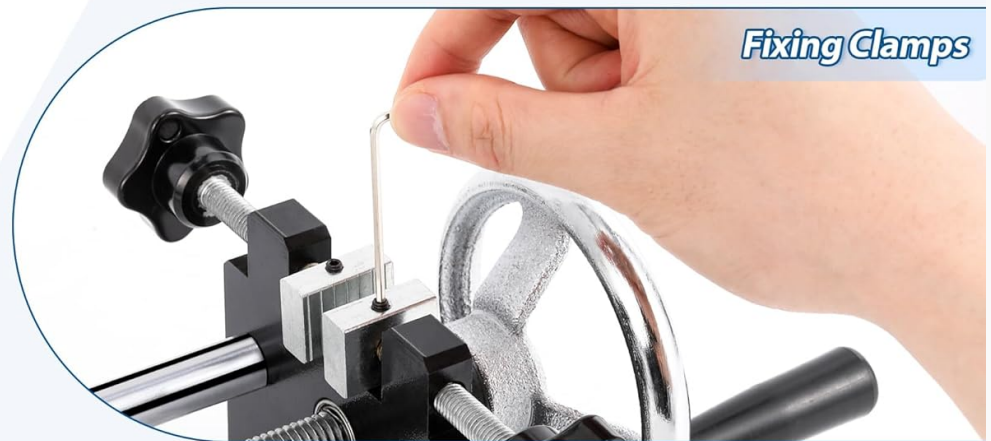
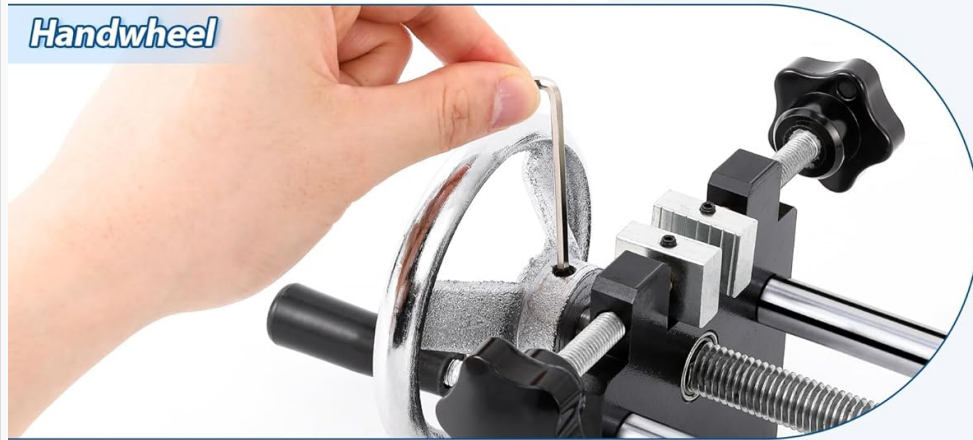

Figure 3.1: Installation of Handwheel and Fixing Clamps. This image illustrates the process of using a hex wrench to secure both the handwheel and the fixing clamps onto the test stand's frame.

2. Mount the DL-100LB Force Gauge:

- The test stand features various mounting holes to accommodate different devices. Select the appropriate holes for your force gauge.
- Secure the force gauge to the movable carriage of the test stand using the provided screws and mounting plates. Ensure it is stable and aligned.

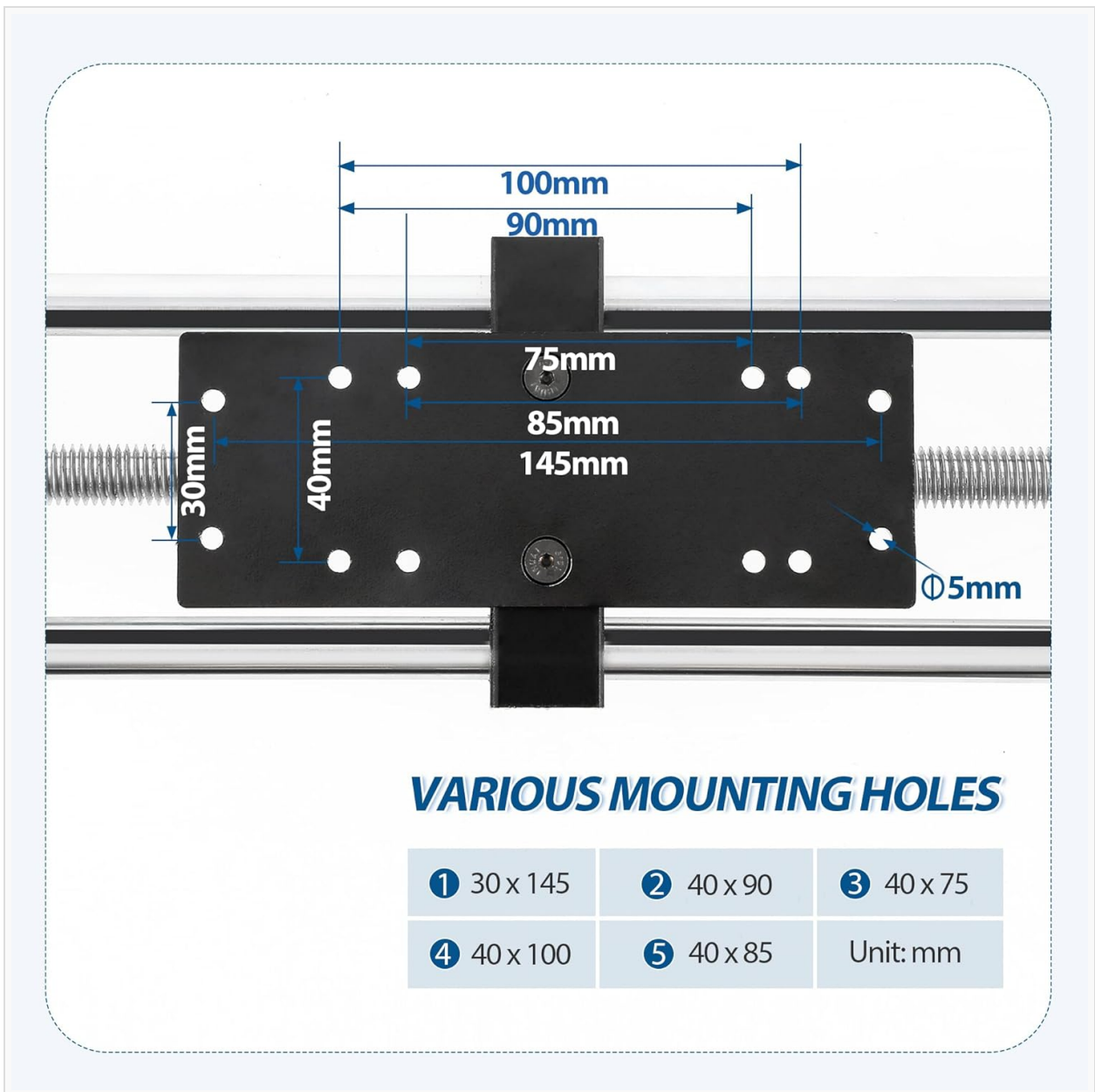

Figure 3.2: Various Mounting Holes on Test Stand. This image highlights the different hole patterns and dimensions available on the test stand's mounting plate, allowing for versatile attachment of various instruments.

3. Attach Test Accessories:

- Select the appropriate metal test accessory (e.g., hook, flat head, cone) based on the material and shape of the object you intend to test.
- Screw the chosen accessory firmly onto the end of the force gauge's measuring rod.

4. OPERATING INSTRUCTIONS

Once assembled, the system is ready for operation:

1. **Position the Object:** Secure the object to be tested onto the test stand using the fixing clamps. Ensure it is stable and will not move during the test.
2. **Adjust Initial Position:** Use the handwheel on the test stand to move the force gauge carriage until the force gauge's measuring rod is in contact with the object. The handwheel allows for very precise control of the measuring stroke.

HANDWHEEL OPERATED

The handwheel operation allows for more precise control of the measuring stroke.



Figure 4.1: Handwheel Operated Test Stand. This image demonstrates the handwheel mechanism, emphasizing its role in providing precise control over the measuring stroke for accurate force application.

3. Perform Measurement:

- For *push* force, turn the handwheel to advance the force gauge against the object.
- For *pull* force, attach the object to the force gauge (e.g., using a hook accessory) and turn the handwheel to retract the force gauge, pulling the object.
- Observe the analog dial on the DL-100LB Force Gauge. The needle will indicate the applied force in pounds (LB).
- Note the peak force reading if required. The gauge may have a peak hold function (refer to the gauge's specific instructions if available).

4. **Release and Reset:** After measurement, retract the force gauge using the handwheel. The gauge's needle should return to zero. If it does not, gently tap the gauge or use any reset mechanism it may have.

5. MAINTENANCE

Proper maintenance ensures the longevity and accuracy of your force measurement system:

- **Cleaning:** Wipe down the force gauge and test stand with a soft, dry cloth after each use. For stubborn dirt, a slightly damp cloth can be used, but ensure no moisture enters the internal mechanisms.
- **Lubrication:** Periodically apply a small amount of light machine oil to the threaded rod and sliding parts of the test stand to ensure smooth operation. Avoid over-lubrication.
- **Storage:** Store the device in a clean, dry environment, away from direct sunlight, extreme temperatures, and corrosive substances. Keep it in its original carrying case if available to protect it from dust and impact.
- **Calibration:** For critical applications, periodic calibration of the force gauge by a certified laboratory is recommended to maintain accuracy. Refer to the calibration certificate for details on recommended intervals.

6. TROUBLESHOOTING

If you encounter issues during operation, refer to the following common problems and solutions:

- **Issue:** Force gauge needle does not return to zero.
Solution: Gently tap the side of the gauge. If the issue persists, check for any obstructions or damage to the measuring rod. Avoid applying excessive force beyond the gauge's capacity.
- **Issue:** Test stand movement is stiff or jerky.
Solution: Clean the threaded rod and guide rails. Apply a small amount of light machine oil to lubricate these components. Check for any debris or foreign objects obstructing the movement.
- **Issue:** Inconsistent force readings.
Solution: Ensure the force gauge and the object under test are securely mounted and stable. Verify that the force is applied smoothly and consistently. Check if the test accessory is properly attached. Consider professional calibration if accuracy issues persist.
- **Issue:** Handwheel is loose.
Solution: Re-tighten the set screw on the handwheel using the appropriate hex wrench.

7. SPECIFICATIONS

Key specifications for the BAOSHISHAN DL-100LB Force Gauge and APW Test Stand Extended Version:

Component	Specification
DL-100LB Force Gauge	Max Capacity: 100 LB (Pound) Measurement Type: Push and Pull Display: Analog Dial
APW Test Stand	Max Stroke: 420mm / 16.5 inches Operation: Handwheel Operated Mounting: Various mounting holes (e.g., 30x145mm, 40x90mm, 40x75mm, 40x100mm, 40x85mm)
Overall Dimensions (Test Stand)	Length: Approximately 690mm Max Width: Approximately 205mm Height: Approximately 100mm

DIMENSIONS

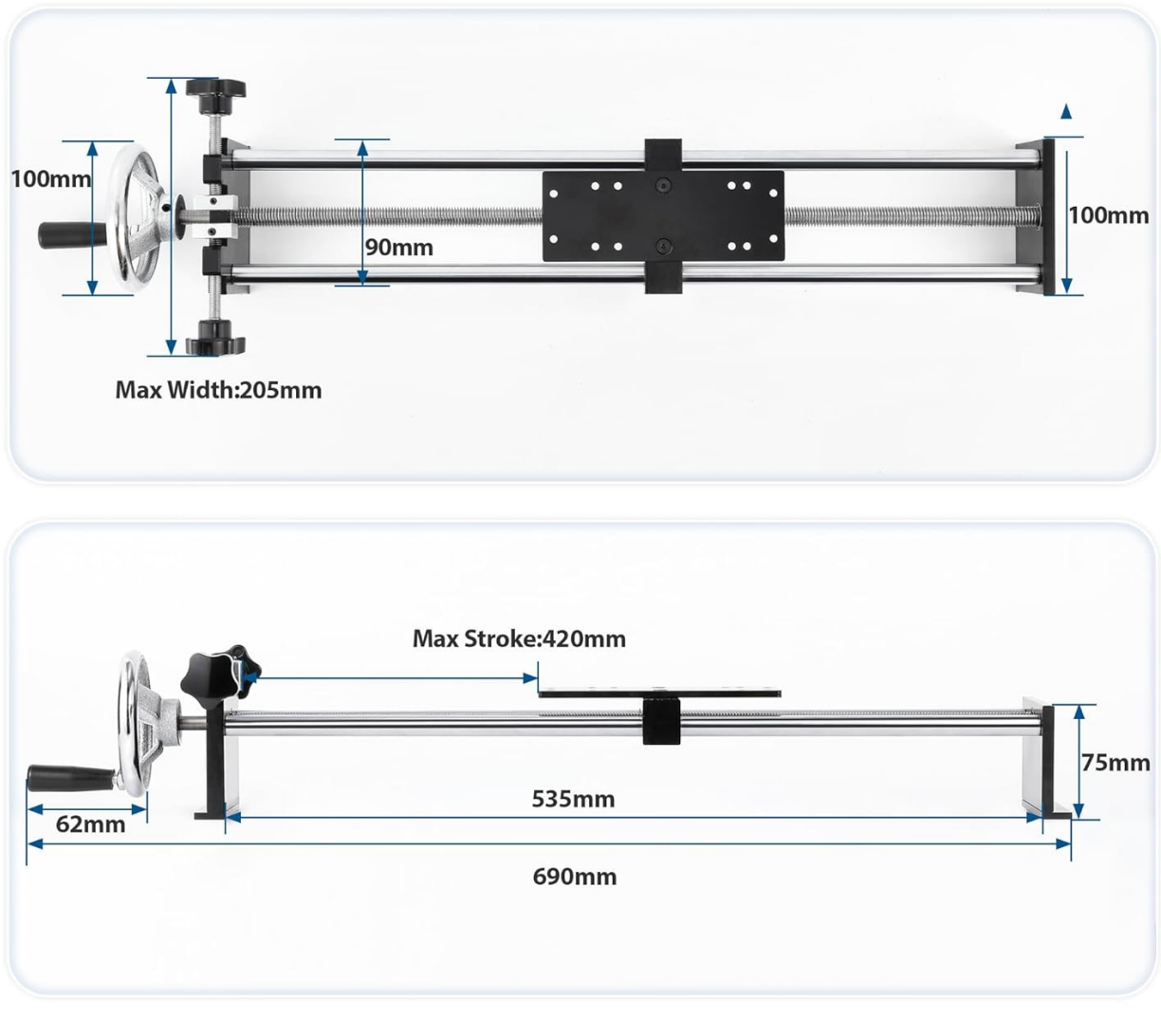

Figure 7.1: Dimensions of APW Test Stand. This image provides detailed measurements for the test stand, including its overall length, width, height, and maximum stroke, crucial for planning its placement and use.

8. PACKING LIST

Upon unboxing, verify that all items listed below are present:

- DL-100LB Force Gauge * 1
- APW Test Stand Extended Version * 1
- Metal Test Accessories * 5 (various types)
- Extension Rod * 1
- Carrying Case * 1 (for force gauge and accessories)
- Screws * 4 (for mounting)
- Hex Wrenches (for assembly)
- Calibration Certificate * 1
- Quality Certificate * 1
- User Manual * 1 (this document)



Figure 8.1: Packing List and Certificates. This image displays the contents of the product packaging, including the force gauge, accessories, and accompanying documentation such as the calibration and quality certificates, and the user manual.