



Manuals.plus /

› CARPETNAL /

› CARPETNAL White 7-Drawer Dresser Instruction Manual (Model FH0020WH)

CARPETNAL FH0020WH

CARPETNAL White 7-Drawer Dresser Instruction Manual

Model: FH0020WH

1. IMPORTANT SAFETY INFORMATION

Please read and understand all instructions before assembly and use. Keep this manual for future reference. Failure to follow these instructions may result in injury or damage to the product.

- **Anti-Tip Kit:** Always install the included anti-tip kit to prevent serious or fatal crushing injuries from furniture tip-over. Secure the dresser to a wall using the provided hardware.
- **Weight Limits:** Do not exceed the recommended weight limits for the dresser top or individual drawers. Distribute weight evenly.
- **Children Safety:** Do not allow children to climb on or play with the dresser. Keep heavy items in the lowest drawers.
- **Placement:** Place the dresser on a level surface to ensure stability.

2. PACKAGE CONTENTS

Before beginning assembly, ensure all parts and hardware are present. Refer to the detailed parts list included in your packaging. If any parts are missing or damaged, please contact customer service.

3. SETUP & ASSEMBLY

Assembly is required for this dresser. Follow the step-by-step instructions provided in the included assembly guide. It is recommended to have two people for assembly.

Assembly Overview



Image: The fully assembled CARPETNAL White 7-Drawer Dresser, showcasing its design and gold handles.

Dimensions and Drawer Sizes

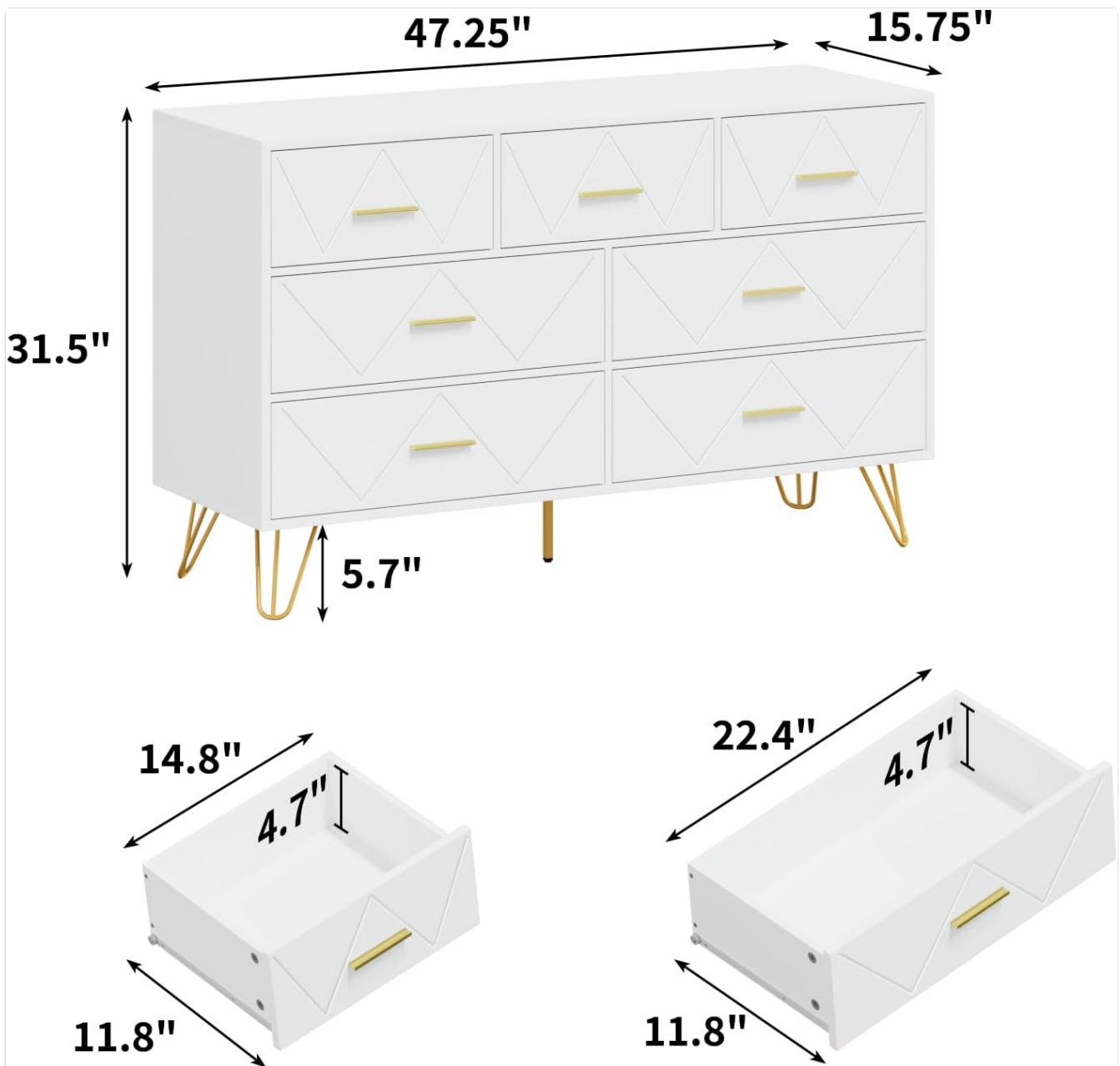

Image: Visual representation of the dresser's overall dimensions (47.25"L x 15.75"W x 31.5"H) and the internal measurements of the two different drawer sizes.

Assembly Video

Your browser does not support the video tag.

Video: An official CARPETNAL HOME video demonstrating the assembly process and features of the White 7-Drawer Dresser.

4. OPERATING INSTRUCTIONS

The CARPETNAL 7-Drawer Dresser is designed for convenient and organized storage in various rooms.

- **Drawer Operation:** Each drawer is equipped with a smooth sliding system for easy opening and closing. Avoid forcing drawers.
- **Storage Capacity:** The dresser features 7 spacious drawers, providing ample space for clothing, cosmetics, jewelry, photo albums, or other personal items. The large top surface can hold decorations, lamps, or potted plants.
- **Versatile Placement:** This dresser is suitable for bedrooms, living rooms, hallways, or entryways. It can also function as a media console for small TVs or gaming systems.

Drawer Features and Capacity



Image: Illustrates the deep and wide drawers, capable of holding a variety of items, highlighting the ample storage space.

5. MAINTENANCE & CARE

To maintain the appearance and longevity of your dresser, follow these care guidelines:

- **Cleaning:** Wipe the dresser surfaces with a dry, soft cloth. Avoid abrasive cleaners or harsh chemicals that may damage the finish.
- **Spills:** Promptly clean any spills to prevent staining, especially on the lacquered finish.
- **Durability:** The dresser is constructed from high-quality certified MDF and features a waterproof, scratch-resistant, and wear-resistant lacquered finish for long-lasting use.

Key Features



Image: Detailed view of the dresser's construction and design elements, including the unique drawer pattern, gold handles, metal feet, and the smooth drawer mechanism.

6. TROUBLESHOOTING

If you encounter any issues with your dresser, please refer to the following common solutions or contact customer service.

- **Missing Parts:** If any parts are missing upon arrival, verify against the parts list in the assembly manual and contact customer service for replacements.
- **Drawers Not Closing/Fitting:** Ensure all drawer slides are correctly installed and aligned. Check for any obstructions within the drawer or on the slides.
- **Stability Issues:** Confirm the dresser is on a level surface and the anti-tip kit is securely installed.

7. SPECIFICATIONS

Feature	Detail
Brand	CARPETNAL
Model Name	7 drawer dresser-20
Model Number	FH0020WH
Product Dimensions	15.75"D x 47.25"W x 31.5"H
Color	White
Material	Engineered Wood
Finish Type	Lacquered
Number of Drawers	7
Item Weight	99 Pounds
Assembly Required	Yes
UPC	749759996171

8. WARRANTY & SUPPORT

CARPETNAL is committed to providing quality products and customer satisfaction. For any questions, concerns, or assistance with your dresser, please contact our customer service team.

- **Customer Service:** Refer to the contact information provided in your product packaging or visit the official CARPETNAL website for support.
- **Protection Plans:** Extended protection plans may be available for purchase. Please check with your retailer for details.
- **Returns:** This product is eligible for 30-day easy returns.