

SOBOUR CDG1-1DD 40A

SOBOUR CDG1-1DD Solid State Relay User Manual

Model: CDG1-1DD Series (e.g., 10A, 25A, 40A, 60A, 80A)

1. INTRODUCTION

The SOBOUR CDG1-1DD Solid State Relay (SSR) is an electronic switching device designed for reliable and silent operation in various DC control DC applications. Unlike traditional mechanical relays, SSRs offer advantages such as no moving parts, no contact bounce, no spark generation, and a longer operational life. This manual provides essential information for the safe installation, operation, and maintenance of your CDG1-1DD series solid state relay.

2. SAFETY INFORMATION

Please read and understand all safety instructions before installing or operating this device. Failure to follow these instructions may result in electric shock, fire, or serious injury.

- Always disconnect power to the circuit before installing, wiring, or performing maintenance on the relay.
- Installation should only be performed by qualified personnel familiar with electrical systems and safety procedures.
- Ensure that the relay's voltage and current ratings are suitable for your application. Overloading can cause damage or fire.
- Use appropriate wire gauges for the load current to prevent overheating.
- Mount the relay in an area with adequate ventilation to prevent overheating, especially for higher current models.
- Do not expose the relay to moisture, corrosive gases, or excessive vibrations.

3. PRODUCT OVERVIEW

The SOBOUR CDG1-1DD is a single-phase DC control DC solid state relay. It features a compact design and provides reliable switching without mechanical contacts, eliminating sparks and extending operational life. The relay is designed for various industrial and commercial applications requiring precise DC load control.

CDG1-1DD

No spark



Solid state relay

Figure 3.1: Front view of the SOBOUR CDG1-1DD Solid State Relay, showing input and output terminals.

No contact, no spark



Figure 3.2: Angled view highlighting the "No contact, no spark" feature and connection points for control and load circuits.

Key Features:

- **DC Control DC:** Designed to switch DC loads using a DC control signal.
- **No Spark Operation:** Eliminates electrical arcing, enhancing safety and component life.
- **High Reliability:** Solid-state design ensures long-term stability and performance.
- **Wide Current Range:** Available in various current ratings (10A, 25A, 40A, 60A, 80A) to suit different applications.

4. SPECIFICATIONS

The following table outlines the general specifications for the SOBOUR CDG1-1DD series. Specific current ratings vary by model.

Parameter	Value
Model Series	CDG1-1DD
Control Voltage (Input)	3V ~ 32V DC
Load Voltage (Output)	DC-12: 220V DC (Max)
Load Current Options	10A, 25A, 40A, 60A, 80A
Operating Principle	DC Control DC
Isolation Voltage	> 2500V AC
On-State Voltage Drop	< 1.6V
Off-State Leakage Current	< 5mA
Response Time	< 10ms
Mounting Method	Panel Mount (Screw terminals)
Dimensions (Approx.)	48.5mm (L) x 45.5mm (W) x 31.5mm (H)
Weight (40A model)	3.53 ounces (approx. 100g)
Manufacturer	SOBOUR

Dimensions

注：(单位mm)

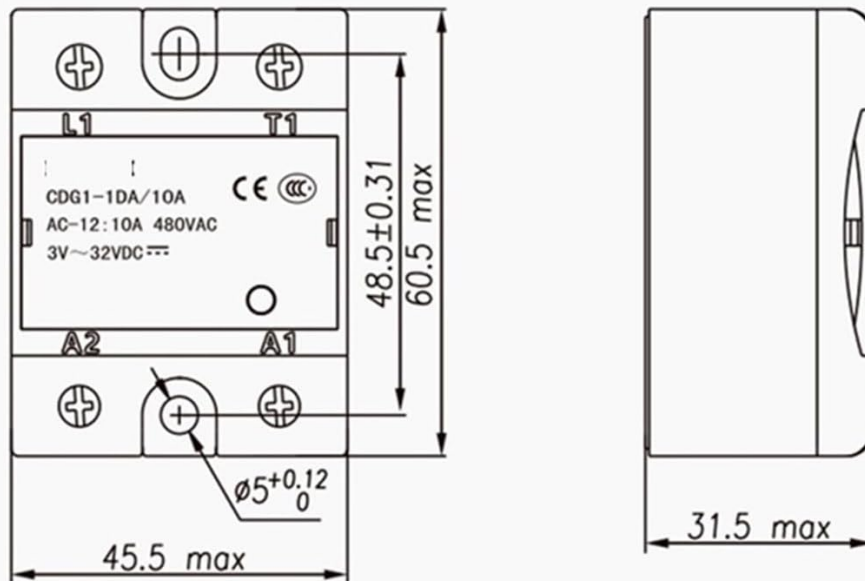

Figure 4.1: Detailed dimensions of the CDG1-1DD Solid State Relay in millimeters.

5. SETUP & INSTALLATION

Proper installation is crucial for the safe and efficient operation of the solid state relay. Refer to the wiring diagrams and follow these steps carefully.

5.1 Mounting

- Mount the relay on a flat, stable surface using screws through the designated mounting holes.
- For higher current models (e.g., 40A and above), it is highly recommended to use a heatsink to dissipate heat and prevent thermal damage. Ensure good thermal contact between the relay and the heatsink.
- Allow sufficient clearance around the relay for air circulation, especially if not using a heatsink.

5.2 Wiring Connections (DC Control DC)

The CDG1-1DD series is designed for DC control of DC loads. The input terminals (A1, A2) control the switching of the output terminals (L1, T1).

Connection mode

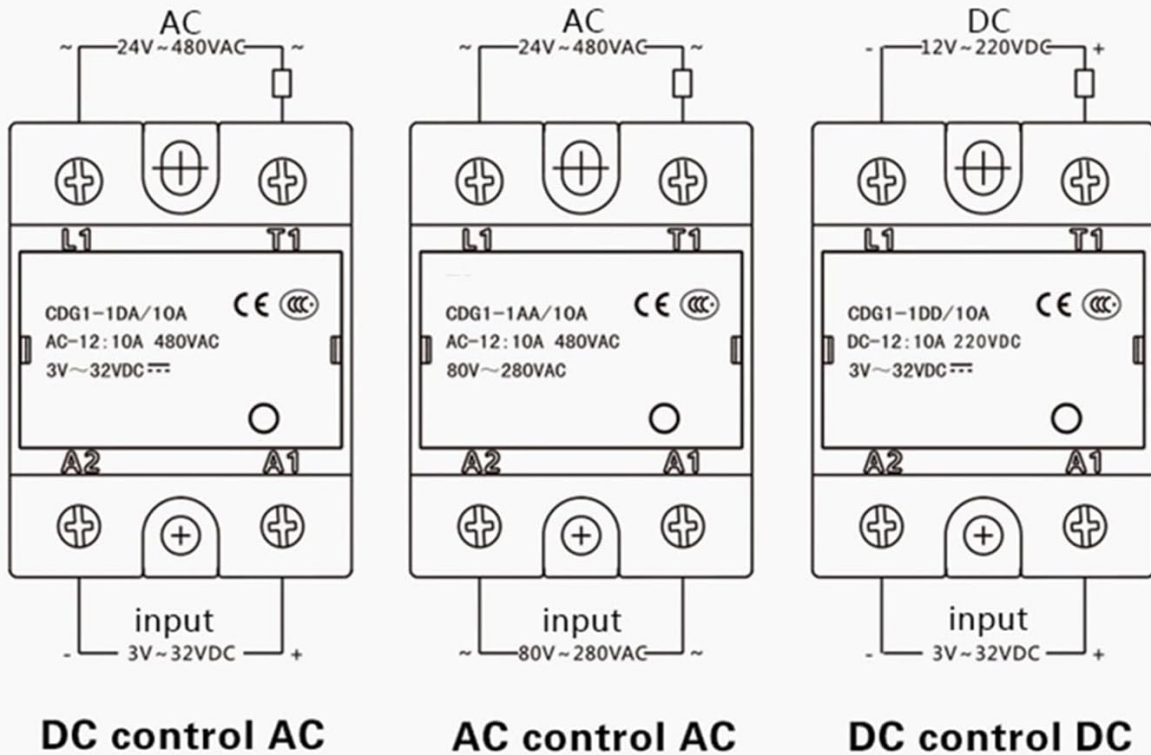

Figure 5.1: Connection diagram for DC control DC solid state relay (CDG1-1DD). Input is 3V-32VDC, output is DC-12V-220VDC.

1. Control Input (A1, A2):

- Connect the positive (+) terminal of your DC control power supply (3V-32V DC) to terminal **A1**.
- Connect the negative (-) terminal of your DC control power supply to terminal **A2**.
- Ensure the control voltage is within the specified range (3V-32V DC).

2. Load Output (L1, T1):

- Connect the positive (+) terminal of your DC load power supply to terminal **L1**.
- Connect one side of your DC load (e.g., motor, heater, LED strip) to terminal **T1**.
- Connect the other side of your DC load to the negative (-) terminal of your DC load power supply.
- Ensure the load voltage and current are within the relay's specified ratings.

3. **Verify Connections:** Double-check all wiring for correct polarity and secure connections before applying power. Loose connections can cause overheating and damage.

6. OPERATING INSTRUCTIONS

Once properly installed and wired, operating the SOBOUR CDG1-1DD Solid State Relay is straightforward:

1. **Apply Load Power:** Ensure the DC load power supply is connected and ready.
2. **Apply Control Signal:** Apply the specified DC control voltage (3V-32V DC) to the input terminals (A1, A2).
3. **Relay Activation:** When the control voltage is applied, the internal solid-state switch will close, allowing current to flow through the load circuit (L1 to T1), activating your DC load.
4. **Relay Deactivation:** When the control voltage is removed from A1 and A2, the internal solid-state switch will open, interrupting the current flow to the load and deactivating it.

The relay operates silently and without mechanical wear, providing a fast and reliable switching action.

7. MAINTENANCE

The SOBOUR CDG1-1DD Solid State Relay is designed for maintenance-free operation due to its solid-state nature. However, periodic checks can help ensure optimal performance and longevity:

- **Visual Inspection:** Periodically inspect the relay for any signs of physical damage, discoloration (indicating overheating), or loose connections.
- **Connection Integrity:** Ensure all terminal screws are tight and wires are securely connected. Loose connections can lead to increased resistance and heat.
- **Cleanliness:** Keep the relay and its surroundings free from dust, dirt, and debris, which can impede heat dissipation. Use a soft, dry cloth for cleaning.
- **Thermal Management:** If a heatsink is used, ensure it is clean and free of obstructions. Verify that the ambient temperature remains within the relay's operating limits.

8. TROUBLESHOOTING

If you encounter issues with your SOBOUR CDG1-1DD Solid State Relay, refer to the following troubleshooting guide:

Problem	Possible Cause	Solution
Relay does not switch ON (load remains OFF)	<ul style="list-style-type: none"> ◦ No control voltage or incorrect polarity. ◦ Control voltage too low (below 3V DC). ◦ Loose control input connections. ◦ No load power or incorrect polarity. ◦ Load circuit open. ◦ Damaged relay. 	<ul style="list-style-type: none"> ◦ Verify control voltage (3V-32V DC) and polarity at A1/A2. ◦ Check control power supply. ◦ Tighten A1/A2 connections. ◦ Verify load power supply and polarity at L1/T1. ◦ Check load for continuity. ◦ Replace relay if all other checks pass.
Relay does not switch OFF (load remains ON)	<ul style="list-style-type: none"> ◦ Control voltage still present. ◦ Internal short circuit in relay. 	<ul style="list-style-type: none"> ◦ Ensure control voltage is completely removed from A1/A2. ◦ Replace relay.
Relay overheats	<ul style="list-style-type: none"> ◦ Load current exceeds relay rating. ◦ Insufficient heatsinking or ventilation. ◦ Loose power connections. ◦ High ambient temperature. 	<ul style="list-style-type: none"> ◦ Reduce load current or use a higher-rated relay. ◦ Install an appropriate heatsink or improve ventilation. ◦ Tighten L1/T1 connections. ◦ Ensure operating environment is within temperature limits.

If the problem persists after performing these checks, contact SOBOUR customer support for further assistance.

9. WARRANTY AND SUPPORT

SOBOUR products are manufactured to high-quality standards. For information regarding warranty coverage, technical support, or replacement parts, please refer to the product packaging or contact SOBOUR customer service directly. Keep your purchase receipt as proof of purchase.

Contact information can typically be found on the manufacturer's official website or on the product's packaging.