

[Manuals.plus](#) /

› [TMEZON](#) /

› TMEZON Wired Video Intercom System User Manual

TMEZON MZ-V20

TMEZON Wired Video Intercom System User Manual

Model: MZ-V20

PRODUCT OVERVIEW

The TMEZON Wired Video Intercom System provides enhanced security and convenience for your home or office. This system includes a 7-inch color LCD indoor monitor and an outdoor doorbell with an HD camera, offering clear visual and audio communication with visitors.

Key features include:

- **7-inch Color LCD Monitor:** Easy-to-operate system with a slim design and touch buttons.
- **HD Outdoor Doorbell Camera:** Features a 115-degree wide viewing angle, high definition video, night vision capabilities, and a rainproof, anti-vandal design.
- **Dual-Way Intercom:** Enables two-way audio communication between the indoor monitor and the outdoor unit.
- **Unlock Functionality:** Supports connection to electronic locks for remote unlocking.
- **Monitoring:** Allows live viewing of the outdoor area from the indoor monitor.



Figure 1: TMEZON Wired Video Intercom System showing the indoor monitor and outdoor doorbell unit.

COMPONENTS AND FEATURES

Outdoor Doorbell Unit

Smart doorbell



Figure 2: Detailed view of the outdoor doorbell unit components.

The outdoor unit is designed for durability and clear communication:

- **Rain Shade:** Provides protection against weather elements.
- **Mic:** Captures audio for two-way communication.
- **Camera:** High-definition camera with a wide viewing angle.
- **Photocell:** Detects ambient light for automatic night vision activation.
- **LED Light:** Illuminates the area for clear night vision.
- **Name Plate:** For identification.
- **CALL button:** Initiates a call to the indoor monitor.
- **Speaker:** Outputs audio for two-way communication.



Figure 3: The outdoor unit features an IP55 weatherproof rating, ensuring reliable operation in various weather conditions.

Indoor Monitor

The 7-inch indoor monitor serves as the central control unit for the intercom system. It features touch-sensitive buttons for various functions.

One-key Unlock



Figure 4: The indoor monitor allows for one-key unlocking of connected electronic locks.

The monitor provides a clear view of the outdoor camera feed and allows for interaction with visitors.

Day and Night

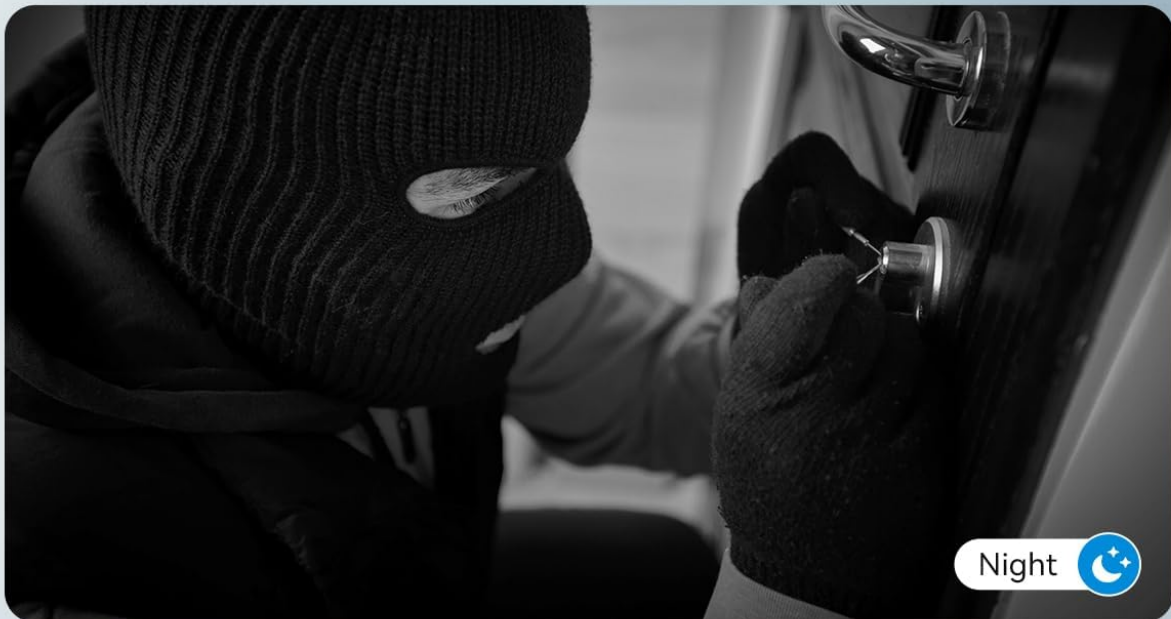

Figure 5: The system provides clear video both day and night, with automatic switching to night vision in low light conditions.

The system also offers a selection of 16 ringtones to personalize your doorbell alerts.



Figure 6: Choose from 16 different ringtones to customize your system's alerts.

SETUP AND INSTALLATION

The TMEZON Wired Video Intercom System is designed for easy installation, primarily using a 4-wire connection. Proper wiring is crucial for optimal performance.

Wiring Diagram

Easy Installation

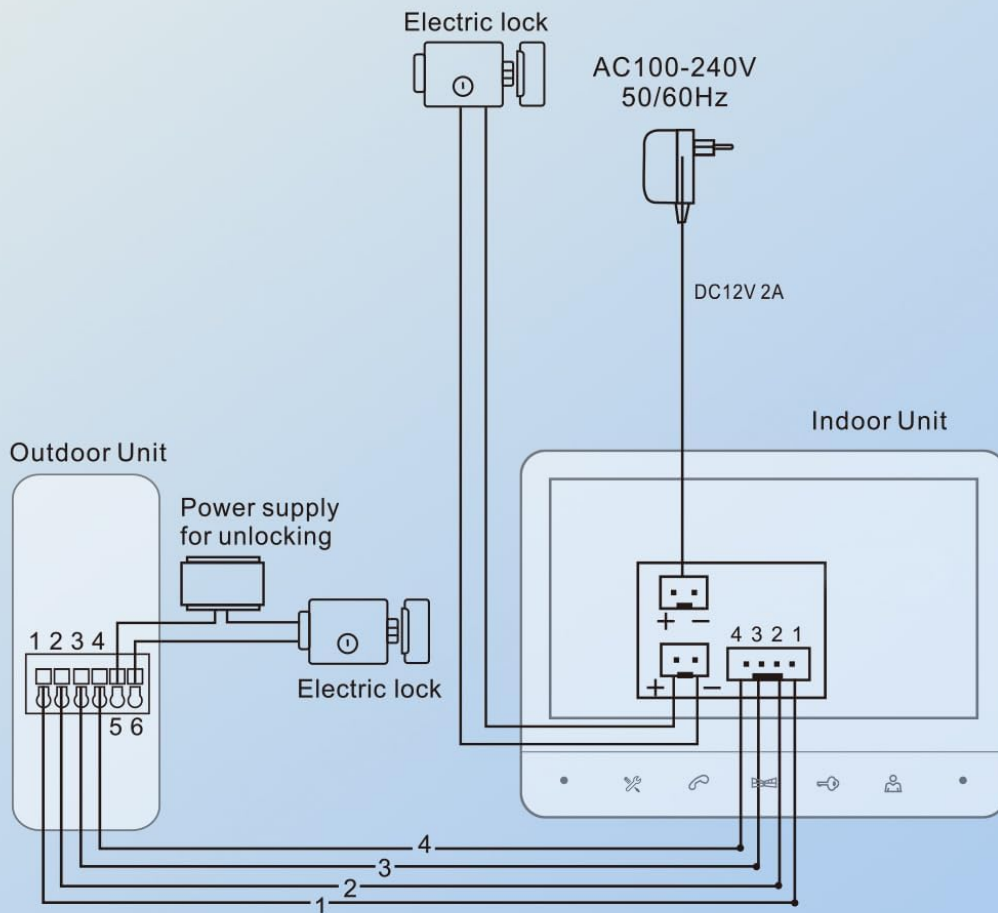

Figure 7: Wiring diagram for connecting the outdoor unit, indoor unit, and electric lock.

Connection Steps:

- 1. Power Supply:** Connect the DC12V 2A power adapter to the Indoor Unit. The power adapter supports AC100-240V, 50/60Hz input.
- 2. Outdoor Unit to Indoor Unit:** Use a 4-wire cable to connect the outdoor unit to the indoor unit. Ensure correct polarity for each wire (labeled 1, 2, 3, 4 on the outdoor unit and corresponding terminals on the indoor unit).
- 3. Electric Lock Connection:**
 - For electric locks requiring power from the intercom system, connect the lock to the designated terminals on the outdoor unit (e.g., 5 and 6).
 - For electric locks with independent power supply, connect them as per their specific instructions,

ensuring compatibility with the intercom's unlock signal.

4. **Mounting:** Securely mount the outdoor unit to a wall, ideally with the provided rain shade. Mount the indoor monitor on an interior wall at a convenient height.

Before final mounting, it is recommended to test all connections to ensure proper functionality.

OPERATING INSTRUCTIONS

Receiving a Call

When a visitor presses the CALL button on the outdoor unit, the indoor monitor will ring and display the visitor's image. You can then:

- **Answer:** Press the "Talk" button on the monitor to initiate two-way audio communication.
- **Unlock:** Press the "Unlock" button to open a connected electronic lock.
- **Monitor:** If you miss a call or wish to view the outdoor area, press the "Monitor" button.



Figure 8: Engage in clear two-way audio communication with visitors at your door.

Monitoring

To view the outdoor camera feed at any time, press the "Monitor" button on the indoor unit. The screen will display the live video feed from the outdoor doorbell. This feature is useful for checking your surroundings before opening the door.

Unlocking the Door

If an electronic lock is connected, simply press the "Unlock" button on the indoor monitor during a call or while monitoring to grant access.

Settings and Ringtones

The indoor monitor allows access to settings for adjusting various parameters, including ringtone selection. Navigate through the menu using the directional buttons (Increase/Decrease) and confirm selections. There are 16 different ringtones available to choose from.

MAINTENANCE

Regular maintenance ensures the longevity and optimal performance of your TMEZON Video Intercom System.

- **Cleaning:** Use a soft, dry cloth to clean the indoor monitor screen and the outdoor unit. Avoid abrasive cleaners or solvents that could damage the surfaces. For the outdoor unit, ensure the camera lens is free of dust or smudges for clear video quality.
- **Outdoor Unit Inspection:** Periodically check the outdoor unit for any signs of wear, damage, or obstruction to the camera or microphone. Ensure the rain shade is securely in place.
- **Wiring Check:** If you experience intermittent issues, a visual inspection of the wiring connections (if accessible) can help identify loose or damaged cables.
- **Environmental Considerations:** While the outdoor unit is IP55 weatherproof, extreme weather conditions (e.g., heavy snow, prolonged direct sunlight) should be considered for optimal placement and protection.

TROUBLESHOOTING

Common Issues and Solutions

Problem	Possible Cause	Solution
No image on indoor monitor	No power to monitor; loose wiring; faulty camera.	Check power adapter connection. Verify all 4-wire connections are secure. Ensure outdoor unit is powered.
No audio or distorted audio	Loose audio wires; obstructed microphone/speaker; volume too low.	Check audio wire connections. Clear any obstructions from mic/speaker on both units. Adjust volume settings on the indoor monitor.
Door unlock not working	Incorrect wiring to electric lock; lock requires separate power supply not connected; faulty lock.	Review the wiring diagram for the electric lock connection. Ensure the electric lock has its own power if required. Test the electric lock independently.
Night vision unclear	Dirty camera lens; insufficient ambient light for photocell; faulty IR LEDs.	Clean the camera lens. Ensure no obstructions are blocking the photocell or IR LEDs.
Monitor not responding to touch	System frozen; power issue.	Disconnect power to the indoor monitor for 30 seconds, then reconnect.

If the problem persists after attempting these solutions, please refer to the warranty and support section for further assistance.

SPECIFICATIONS

Feature	Detail
Model Number	MZ-V20
Indoor Monitor Size	7 inches (LCD Color)
Outdoor Unit Camera	HD, 115-degree wide view angle
Power Source	Power Adapter (AC100-240V, 50/60Hz input)
Voltage	12 Volts
Item Weight	Approximately 2 pounds (total system)
Product Dimensions	1 x 1 x 1 inches (packaging/general product dimensions)
Mounting Type	Wall Mount
Special Features	2-way audio, Night Vision, Unlock function, IP55 Weatherproof (outdoor unit)
Included Components	Monitor, Outdoor Doorbell Unit, Power Adapter, Wiring

Product Size



Figure 9: Product dimensions for the indoor monitor and outdoor unit.

WARRANTY AND SUPPORT

For information regarding the product warranty, please refer to the documentation included with your purchase or contact TMEZON customer support directly. Warranty terms typically cover manufacturing defects for a specified period from the date of purchase.

For technical support, troubleshooting assistance beyond this manual, or inquiries about replacement parts, please visit the official TMEZON website or contact their customer service department. Contact details are usually available on the product packaging or the manufacturer's website.

It is recommended to keep your purchase receipt as proof of purchase for warranty claims.

