



[Manuals.plus](#) /

› [HOMCOM](#) /

› [HOMCOM Rolling Kitchen Island Instruction Manual](#)

HOMCOM 801-332V80CG

HOMCOM Rolling Kitchen Island Instruction Manual

MODEL: 801-332V80CG

[Introduction](#) [Safety Information](#) [Features](#) [Setup & Assembly](#) [Operating Instructions](#)
[Maintenance](#) [Troubleshooting](#) [Specifications](#) [Warranty & Support](#)

1. Introduction

This manual provides comprehensive instructions for the assembly, operation, and maintenance of your HOMCOM Rolling Kitchen Island. Designed to enhance your kitchen space, this mobile cart offers versatile storage and an expandable countertop for various uses, from meal preparation to a casual dining area. Please read this manual thoroughly before assembly and use to ensure safe and efficient operation.



Figure 1: HOMCOM Rolling Kitchen Island, Dark Gray

This image displays the HOMCOM Rolling Kitchen Island in its dark gray finish with a wood-tone countertop. The island features two top drawers and two lower cabinet doors with a barn door style design, and a visible drop leaf on the side.

2. Safety Information

Please observe the following safety guidelines to prevent injury or damage to the product:

- Always use the brakes when the kitchen island is stationary to prevent it from rolling.
- Be cautious when extending and folding the drop leaf to avoid injury.
- Keep fingers away from drawer and cabinet openings to prevent pinching.
- Always follow the assembly instructions carefully to ensure the kitchen island is stable and secure.

3. Product Features

The HOMCOM Rolling Kitchen Island is equipped with several features designed for convenience and functionality:

- **Extendable Countertop:** Features a drop leaf design to create a larger surface for dining or food preparation, which can be folded down for space-saving.

- **Durable Surface:** Boasts a quality and smooth rubberwood tabletop, providing a sturdy work surface.
- **Ample Storage:** Includes two spacious drawers and a double-door cabinet for hidden storage of kitchen essentials.
- **Adjustable Shelves:** The cabinet features adjustable shelves for customizable storage space, accommodating items of various sizes.
- **Mobile Design:** Equipped with four hidden rolling casters for effortless maneuverability, with two locking brakes for stability.



Figure 2: Large Storage Space

This image illustrates the interior storage capacity of the kitchen island, showing the two pull-out drawers and the two-door cabinet opened to reveal adjustable shelves filled with dishes and kitchen items.

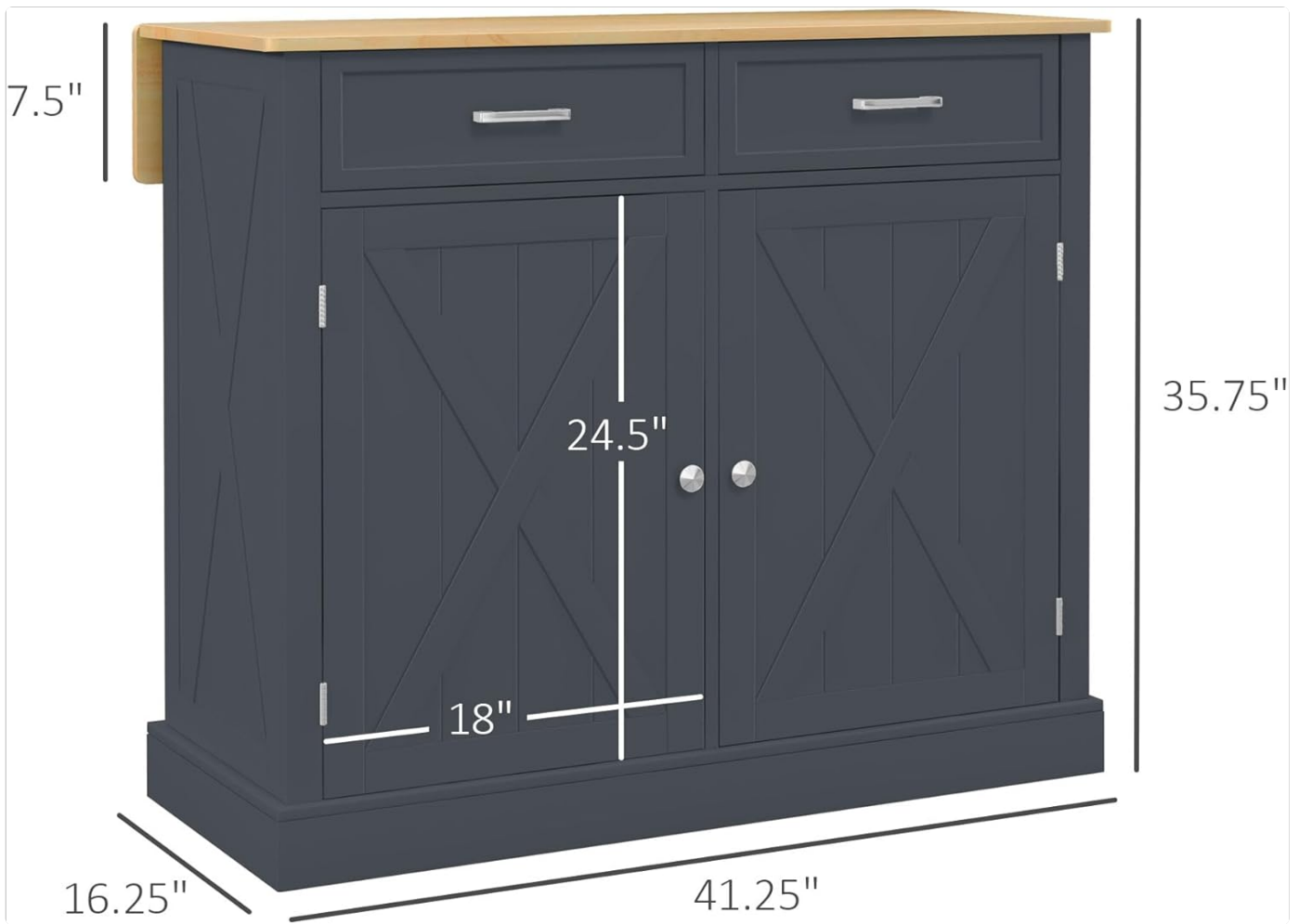

Figure 3: 3-Level Adjustable Shelves

A close-up view demonstrating the three-level adjustable shelves within the cabinet, highlighting their flexibility for customizing storage space.



Figure 4: Easy Movement Casters

This image shows one of the hidden rolling casters located at the bottom of the kitchen island, illustrating its design for easy movement and the presence of a locking brake mechanism.

4. Setup & Assembly

Assembly of the HOMCOM Rolling Kitchen Island is required. Please ensure all components are present and undamaged before beginning. Follow the detailed assembly instructions provided in the packaging. It is recommended to assemble the unit on a soft, clean surface to prevent scratches.

Familiarize yourself with the overall dimensions to ensure the island fits your intended space:

Overall Dimensions: 41.25" L x 23.5" W x 35.5" H

Countertop Size (Extended): 41.25" L x 23.5" W

Countertop Size (Folded): 41.25" L x 16.25" W

EXPANDABLE RUBBER WOOD TOP

Fold it when you need more kitchen space



Extend it when you need more counter space

Figure 5: Product Dimensions

This diagram illustrates the key dimensions of the kitchen island, including its length, width, and height, as well as the dimensions of the drop leaf and cabinet doors.

5. Operating Instructions

5.1 Extending and Folding the Drop Leaf

To extend the countertop, gently lift the drop leaf and pull out the support arms underneath until they are fully extended and locked into place. To fold, push the support arms back in and carefully lower the leaf until it rests against the side of the island.



Figure 6: Drop Leaf Mechanism

A detailed view of the drop leaf in its extended position, showing the supporting bracket that holds the leaf level with the main countertop.

5.2 Using Drawers and Cabinets

The two drawers operate on metal slides for smooth opening and closing. The double-door cabinet provides concealed storage. To adjust the shelves within the cabinet, carefully remove the shelf and reposition the support pegs to the desired height level.

5.3 Moving and Securing the Island

The island is equipped with hidden rolling casters for easy movement. To move the island, ensure the brakes on the casters are disengaged. Once the island is in the desired position, engage the brakes on the two locking casters to secure it in place and prevent accidental rolling.

6. Maintenance

To ensure the longevity and appearance of your kitchen island, follow these maintenance guidelines:

- **Cleaning:** Wipe surfaces with a soft, damp cloth. Avoid abrasive cleaners or harsh chemicals that may damage the finish.
- **Spills:** Clean up spills immediately to prevent staining, especially on the rubberwood countertop.
- **Hardware:** Periodically check and tighten all screws and fittings to ensure stability.
- **Countertop Care:** For the rubberwood top, consider using a food-safe wood conditioner periodically to maintain its luster and protect against moisture.

7. Troubleshooting

This section addresses common issues you might encounter:

7.1 Island is unstable or wobbly

- **Solution:** Check all assembly screws and ensure they are securely tightened. Verify that the island is on a level surface.

7.2 Drawers do not slide smoothly

- **Solution:** Ensure the drawer slides are properly aligned and free of obstructions. A small amount of silicone lubricant can be applied to the slides if needed.

7.3 Wheel locks are difficult to access

- **Solution:** Due to the design, accessing the wheel locks may require tilting the island slightly. Ensure the island is empty before attempting to tilt it to engage or disengage the locks.

8. Specifications

Attribute	Detail
Brand	HOMCOM
Model Name	Kitchen Island
Model Number	801-332V80CG
Color	Dark Gray
Product Dimensions	23.5"D x 41.25"W x 35.5"H
Item Weight	83.8 Pounds
Weight Capacity (Total)	143 lbs.
Weight Capacity (Counter)	44 lbs.
Weight Capacity (Drawer)	11 lbs.
Top Material Type	Rubberwood
Frame Material	Engineered Wood
Number of Shelves	2 (Adjustable)
Number of Drawers	2
Special Feature	Adjustable Shelf, Drop Leaf
Assembly Required	Yes
UPC	196393152935
Manufacturer	Aosom LLC
Date First Available	July 23, 2023

9. Warranty & Support

For customer support, inquiries, or to report any issues with your HOMCOM Rolling Kitchen Island, please refer to the contact information provided at the point of purchase or visit the official HOMCOM store online. Detailed warranty information, if applicable, will be provided with your purchase documentation.

You can visit the HOMCOM Store for more information and products:[HOMCOM Store](#)

© 2025 HOMCOM. All rights reserved.