

Speediance AW-Bench

Speediance Adjustable Weight Bench (Model AW-Bench)

User Instruction Manual

1. INTRODUCTION

Thank you for choosing the Speediance Adjustable Weight Bench, Model AW-Bench. This manual provides essential information for the safe and effective use of your new fitness equipment. Please read it thoroughly before assembly and operation, and keep it for future reference. This bench is designed to enhance your home gym experience with its versatile adjustment options and robust construction.

2. SAFETY INFORMATION

- Always consult with a healthcare professional before starting any new exercise program.
- Ensure the bench is placed on a stable, level surface.
- Keep children and pets away from the equipment during use.
- Inspect the bench for any loose parts, damage, or wear before each use. Do not use if damaged.
- Do not exceed the maximum weight capacity of 880 pounds (400 kg).
- Use proper lifting techniques and maintain control of weights at all times.
- Adjust the bench only when no weight is on it and ensure all locking pins are securely engaged before use.
- Wear appropriate athletic footwear and clothing.

3. PACKAGE CONTENTS

Please check to ensure all components are present and undamaged:

- Speediance Adjustable Weight Bench (Main Frame with Backrest and Seat)
- Assembly Hardware (pre-installed or in a separate bag)
- User Manual

4. SETUP INSTRUCTIONS

The Speediance Adjustable Weight Bench comes largely pre-assembled for convenience. Follow these steps to prepare it for use:

1. Carefully remove the bench from its packaging.
2. Unfold the bench by extending the support legs and backrest.
3. Ensure all pins and adjustment mechanisms are securely locked into place before applying any weight.
4. Place the bench on a flat, stable surface, ensuring ample space around it for safe exercise.



Figure 4.1: The Speediance Adjustable Weight Bench highlighting its 881 LBS stable load capacity.

Product Size

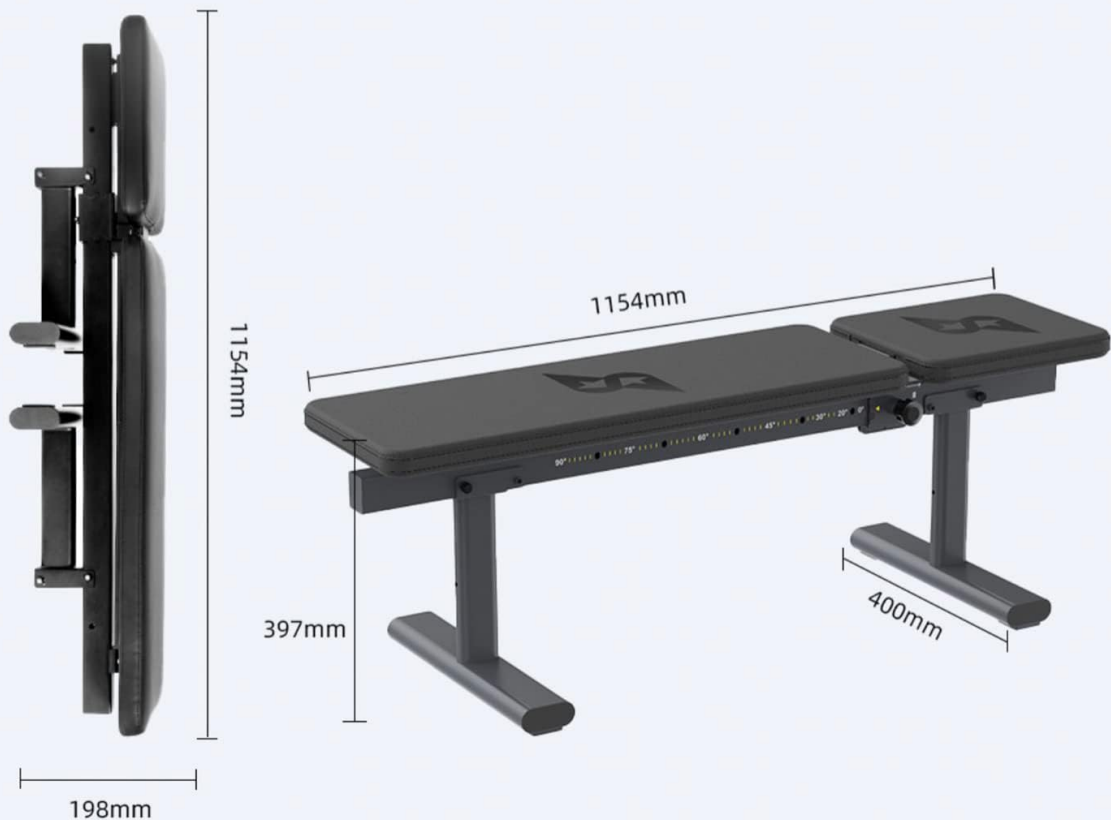

Figure 4.2: Product dimensions, illustrating the bench in both its unfolded and folded configurations for storage.

5. OPERATING INSTRUCTIONS & ADJUSTMENTS

The Speediance Adjustable Weight Bench offers multiple positions for a wide range of exercises. Always adjust the bench before starting your workout.

5.1. Backrest Adjustment

The backrest features 7 incline positions, ranging from 0 to 90 degrees, allowing you to target different muscle groups effectively.

1. Ensure no weight is on the backrest.
2. Locate the adjustment pin or lever mechanism at the base of the backrest.
3. Pull the pin/lever to release the backrest.
4. Adjust the backrest to your desired angle (0°, 20°, 30°, 45°, 60°, 75°, 90°).
5. Release the pin/lever and ensure it securely locks into one of the designated slots. Gently push down on the backrest to confirm stability.

5.2. Seat Adjustment

The seat can be adjusted to 2 positions (0 to 20 degrees) to provide optimal support and comfort during various

exercises.

1. Ensure no weight is on the seat.
2. Locate the adjustment mechanism under the seat.
3. Adjust the seat to your desired position.
4. Ensure the mechanism is securely locked.



Figure 5.1: Visual representation of the adjustable backrest and seat angles, showing a user in an inclined position.



Figure 5.2: A user demonstrating the adjustment of the backrest to a desired incline.



Figure 5.3: A user performing a bent-over row, showcasing the bench's stability during exercise.

5.3. Exercise Examples

The adjustable bench supports a variety of exercises, including:

- **Flat Bench Press:** For chest and triceps.
- **Incline Bench Press:** To target upper chest.
- **Decline Bench Press:** To target lower chest.
- **Dumbbell Rows:** For back muscles.
- **Shoulder Press:** For shoulders (seated or inclined).
- **Bulgarian Split Squats:** Using the bench for leg support.

High-grade Breathable Leather



Figure 5.4: Detail of the high-grade breathable leather upholstery, ensuring comfort during workouts.

6. MAINTENANCE

Regular maintenance ensures the longevity and safe operation of your Speediance Adjustable Weight Bench.

- **Cleaning:** Wipe down the bench with a damp cloth after each use to remove sweat and dirt. Use a mild soap solution for deeper cleaning, then wipe dry. Avoid abrasive cleaners.
- **Inspection:** Periodically check all bolts, nuts, and moving parts for tightness. Tighten any loose fasteners. Inspect the upholstery for tears or excessive wear.
- **Storage:** When not in use, the bench can be folded for compact storage. Store in a dry, cool place away from direct sunlight and extreme temperatures.

7. TROUBLESHOOTING

If you encounter any issues with your Speediance Adjustable Weight Bench, refer to the following common solutions:

| Problem | Possible Cause | Solution |
|---------|----------------|----------|
|---------|----------------|----------|

| Problem | Possible Cause | Solution |
|------------------------------------|--|---|
| Bench feels unstable | Not on a level surface; loose fasteners; adjustment pins not fully engaged. | Move to a level surface; check and tighten all bolts and nuts; ensure all adjustment pins are securely locked. |
| Difficulty adjusting backrest/seat | Mechanism obstructed; dirt/debris in mechanism; weight on the bench during adjustment. | Ensure no weight is on the bench; clear any obstructions; clean the adjustment mechanism. |
| Squeaking noises during use | Loose fasteners; friction between moving parts. | Check and tighten all fasteners; apply a small amount of silicone-based lubricant to pivot points if necessary (avoid oil-based lubricants on plastic parts). |

8. SPECIFICATIONS

| Feature | Specification |
|--------------------------------|--|
| Brand | Speediance |
| Model Number | AW-Bench |
| Material | Metal (Frame: Alloy Steel) |
| Color | Black |
| Product Dimensions (D x W x H) | 119.4 cm x 25.4 cm x 39.9 cm (47 x 10 x 15.7 inches) |
| Item Weight | 18.94 kg (41.75 lbs) |
| Load Capacity | 400 kg (880 lbs) |
| Backrest Adjustment | 7 positions (0° to 90°) |
| Seat Adjustment | 2 positions (0° to 20°) |

9. WARRANTY AND SUPPORT

For warranty information or technical support, please contact Speediance customer service. Keep your purchase receipt as proof of purchase.

For further assistance, please visit the official Speediance store on Amazon or contact the seller directly.